

BM-2000

INSTRUCTION MANUAL

Version 2021.8

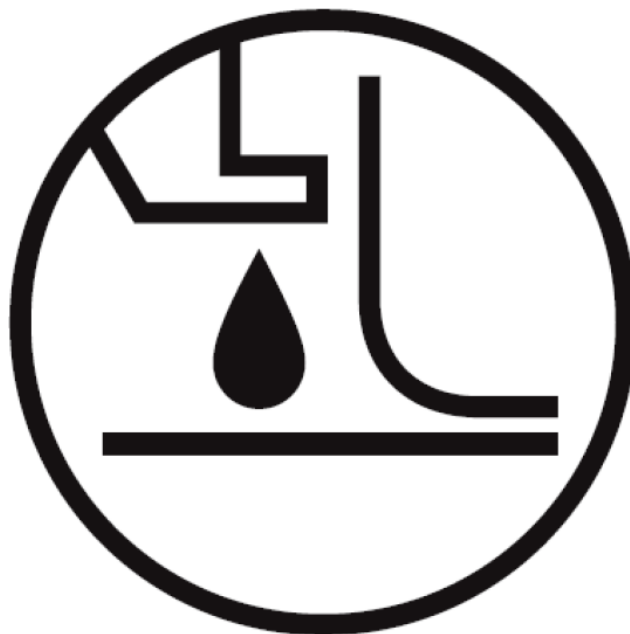

CONTENTS

1. SAFETY INSTRUCTIONS	1	5. GLUING PRE-CONDITION	
1.1 Notes on safety	1	SETTING METHOD	34
1.2 Warning labels.....	3	5.1 Setting nozzle glue width	35
2. NAMES OF MAJOR PARTS	5	5.2 Setting roller pressure.....	35
3. USING THE OPERATION PANEL		5.3 Setting edge control roller pressure.....	37
AND SWITCHES.....	7	5.4 Setting glue thickness.....	38
3.1 Name and function of each operation		5.5 Setting nozzle space.....	39
panel item	7	5.6 Setting glue-free width	40
3.2 Program setting method.....	8	5.7 Setting upper and lower feed speed	41
3.2.1 Parameter list.....	9	6. GLUING	43
3.2.2 Glue thickness setting method.....	10	6.1 Selecting program No.	44
3.2.3 Nozzle clearance setting method.....	11	6.2 Gluing.....	44
3.2.4 Step setting method.....	12	7. GLUING STOP METHOD.....	51
3.2.4.1 Upper and lower roller feed		7.1 Stopping the machine	51
speed setting	14	8. OTHER FUNCTIONS.....	53
3.2.4.2 Upper and lower cloth glue-		8.1 X-over bonding.....	54
free width setting	15	8.2 End detection	55
3.2.4.3 Anti stop mark	16	9. REPLACING GLUE CARTRIDGE.....	56
3.2.5 Comment setting method.....	17	9.1 About glue level indicator.....	56
3.3 Using the switches	18	9.2 Glue cartridge replacing method.....	57
3.3.1 Nozzle switch	18	10. CLEANING	61
3.3.2 GLUE ON/OFF switch.....	18	10.1 Cleaning the upper roller, lower roller	
3.3.3 Knee switch and Op hand switch.....	18	and roller under nozzle	61
3.3.4 Feed speed adjustment switch	19	10.2 Cleaning the nozzle discharge holes	64
3.4 Sleep mode	19	10.3 Cleaning the cloth plate	68
3.4.1 Auto sleep mode	19	10.4 Cleaning the edge control roller	70
3.4.2 Manual sleep mode.....	21	10.5 Cleaning the reflector.....	73
3.5 Memory switch	22	10.6 Charging with cleaner	76
3.5.1 Memory switch setting method		11. PART REPLACEMENT METHOD.....	78
(for operators)	22	11.1 Replacing the nozzle.....	78
3.5.2 Memory switch setting method		11.1.1 Nozzle clearance home position	
(for mechanics)	22	adjustment.....	80
3.5.3 Memory switch setting method	23	11.1.2 Adjusting the nozzle position	
3.5.4 List of memory switch settings		(feed direction)	81
(for operators)	24	11.2 Replacing the lower roller	82
3.5.5 List of memory switch settings		12. STANDARD ADJUSTMENTS	85
(for mechanism)	25	12.1 Changing the gluing width.....	85
3.6 Nozzle light setting method	27	12.1.1 Replacing the nozzle	85
4. PREPARING THE GLUE.....	28	12.1.2 Settings when changing the gluing	
4.1 Starting the machine	30	width	85
4.2 Checking glue discharge.....	32	12.2 Adjusting the anti-entanglement plates.....	88
4.2.1 Manual discharge mode	32	12.2.1 At lower roller side	88
4.2.2 Automatic discharge mode	33	12.2.2 At upper roller side.....	88

12.3 Adjusting the upper cloth and lower cloth sensor amplifiers	90
12.3.1 Summary	90
12.3.2 Setting the light intensity	91
12.4 Adjusting the positioning LED marker	93
12.5 Adjusting the sideways position of the lower edge control sensor	95
12.6 Setting the treadle stroke.....	97
12.7 Adjusting the touch panel key positions ...	99
12.8 Protect settings.....	102
12.8.1 Setting protection for each function individually.....	103
12.8.2 Selecting all items to disallow changing them	104
12.8.3 List of functions that can be protected	105
12.9 Installing the flat bed.....	106
13. SOFTWARE UPGRADE.....	110
13.1 Preparation	110
13.2 Software upgrade	110
14. LIST OF ERROR CODES.....	112

1 SAFETY INSTRUCTIONS

1.1 Notes on safety

WARNING

- Wear protective goggles when operating the bonding machine to avoid getting any glue into your eyes.
- Avoid getting the glue onto your skin. If this is not observed, problems such as burns, inflammation or allergic reactions could result.
- Avoid drinking, eating and smoking while using the glue.
- If the glue is accidentally ingested, problems such as respiratory difficulties or allergic reactions could result.
- Be careful not to get any of the glue which has been applied to the cloth into your eyes or onto your skin. If this is not observed, problems such as inflammation or allergic reactions could result.
- Do not immerse the bonding machine in liquid. Otherwise the main unit may leak and cause fire, electric shocks, or operating problems.
If any liquid leaks from the main unit, immediately turn off the power and disconnect the power plug from the electrical outlet, and then contact a qualified technician.
- Do not place objects on top of the bonding machine.
- Wait at least 5 minutes after turning off the power switch and disconnecting the power cord from the wall outlet before opening the control box cover. Touching areas where high voltages are present will result in serious injury from electric shocks.

CAUTION

<Environmental requirements>

- Use the machine in an area which is free from sources of strong electrical noise such as electrical line noise or static electric noise. Sources of strong electrical noise may cause problems with correct operation.
- Any fluctuations in the power supply voltage should be within $\pm 10\%$ of the rated voltage for the machine. Voltage fluctuations which are greater than this may cause problems with correct operation.
- The power supply capacity should be greater than the requirements for the machine's power consumption. Insufficient power supply capacity may cause problems with correct operation.
- In the event of an electrical storm, turn off the power and disconnect the power cord from the wall outlet. Lightning may cause problems with correct operation.

<Installation>

- Machine installation should only be carried out by a qualified technician.
- Contact your Brother dealer or a qualified electrician for any electrical work that may need to be done.
- Do not connect the power cord until installation is complete.
- Be sure to connect the ground.
If the ground connection is not secure, you run a high risk of serious injury from electric shocks, and problems with correct operation will also occur.
- All cords should be secured at least 25 mm away from any moving parts. Furthermore, do not excessively bend the cords or secure them too firmly with staples.
- If using a table which has casters, the casters should be secured in such a way so that they cannot move.

<Gluing>

- This machine should only be used by operators who have received the necessary training in safe use beforehand.
- Wear protective goggles when operating the bonding machine.
- Attach all safety devices before using the bonding machine. If the bonding machine is used without these devices attached, burns or injury may result.
- Do not touch the nozzle while using or after using the bonding machine. The nozzle becomes hot during use, and burns may result. If there is a chance that you may touch the nozzle, be sure to wear protective gloves which can withstand temperatures of 200°C and higher.
- Do not open the melter cover except when replacing the glue cartridge. The equipment inside the melter cover, the melter, the glue cartridge and the cartridge valve become hot during use and may cause burns if touched.
- Do not touch any of the moving parts or press any objects against the machine while using the bonding machine, as this may result in injury or damage to the bonding machine.
- If an error occurs in machine operation, or if abnormal noises or smells are noticed, immediately turn off the power switch. Then contact a qualified technician.
- If the machine develops a problem, contact your nearest Brother dealer or a qualified technician.

<Cleaning>





- Turn off the power switch before carrying out this operation.





<Maintenance and inspection>

- Maintenance and inspection of the bonding machine should only be carried out by a qualified technician.
- Ask your Brother dealer or a qualified technician to carry out any maintenance and inspection of the electrical system and replacement of system parts.
- Turn off the power switch before inserting or removing the plug. If this is not done, damage to the control box could result.
- If the power switch when carrying out some adjustment, be extremely careful to observe all safety precautions.
- When replacing parts and installing optional accessories, be sure to use only genuine Brother parts.
Brother will not be held responsible for any accidents or problems resulting from the use of non-genuine parts.
- If any safety devices have been removed, be absolutely sure to re-install them to their original positions and check that they operate correctly before using the machine.
- To prevent accidents and problems, do not modify the machine yourself.
Brother will not be held responsible for any accidents or problems resulting from modifications made to the machine.

1.2 Warning labels

The following warning labels appear on the bonding machine. Please follow the instructions on the labels at all times when using the machine. If the labels have been removed or are difficult to read, please contact your nearest Brother dealer.

1			 WARNUNG	
	警告		 AVERTISSEMENT	
	カートリッジ交換作業 目や手を火傷する。保護メガネ、耐熱手袋を着用のこと		Remplacement de la cartouche Porter des lunettes de protection et des gants résistants à la chaleur. Dans le cas contraire, les mains ou les yeux pourraient être blessés.	
	WARNING		 ADVERTENCIA	
Cartridge replacement Wear protective glasses and heat-resistant gloves. Otherwise burns to eyes or hands could occur.		Reemplazo del cartucho Utilice lentes protectoras y guantes resistentes al calor. De lo contrario, podrían producirse quemaduras en los ojos o las manos.		

2		 危険		 危険			
		高電圧部分にふれて、大けがをすることがある。 電源を切り、5分たってからカバーをはずすこと。		触摸高电压部分，会导致受伤。 在切断电源5分钟后，再开启盖罩。			
 DANGER		 GEFAHR		 DANGER		 PELIGRO	
Hazardous voltage will cause injury. Turn off main switch and wait 5 minutes before opening this cover.		Hochspannung verletzungsgefahr! Bitte schalten sie den hauptschalter aus und warten sie 5 minuten, bevor sie diese abdeckung öffnen.		Un voltage non adapte provoque des blessures. Eteindre l'interrupteur et attendre 5 minutes avant d'ouvrir le capot.		Un voltaje inadecuado puede provocar las heridas. Apagar el interruptor principal y esperar 5 minutos antes de abrir esta cubierta.	

3  Be sure to connect the ground. If the ground connection is not secure, you run a high risk of serious injury from electric shocks, and problems with correct operation will also occur.

PE

5  They become hot during use, and burns may result. If you need to touch the displayed location, wear protective gloves (*2).

4  Be careful to avoid injury from the moving upper roller. Be careful to avoid getting your hand caught when the nozzle lever is moved backward.

1 SAFETY INSTRUCTIONS

6

⚠ 注意	
	
<p>接着作業 高温部に触れると火傷する。ノズルで指を挟み火傷する。 露出の少ない衣類を着用すること</p>	
⚠ CAUTION	
<p>Bonding operation Touching hot parts may cause burns. Getting fingers caught by the nozzle may cause burns. Wear clothing that does not expose your skin.</p>	
⚠ VORSICHT	
<p>Klebevorgang Beim Berühren heißer Teile können Verbrennungen auftreten. Wenn Finger von der Düse eingeklemmt werden, kann dies zu Verbrennungen führen. Tragen Sie Kleidung, die Ihre Haut richtig abdeckt.</p>	
⚠ ATTENTION	
<p>Opération de collage Le contact avec des pièces chaudes peut provoquer des brûlures. Des brûlures aux doigts peuvent être provoquées si ceux-ci se retrouvent pris dans la buse. Porter des vêtements qui n'exposent pas la peau.</p>	
⚠ ATENCIÓN	
<p>Trabajo de pegado Tocar piezas calientes puede provocar quemaduras. Si quedan sus dedos atrapados en la boquilla, puede provocar quemaduras. Utilice prendas que no dejen la piel expuesta.</p>	

⚠ 警告	
	
<p>胶盒更换 请佩戴护目镜和隔热手套。 否则会灼伤眼睛或手。</p>	
⚠ WARNING	
<p>Cartridge replacement Wear protective glasses and heat-resistant gloves. Otherwise burns to eyes or hands could occur.</p>	

⚠ 注意	
	
<p>粘合作業 触摸高温部件可能会导致灼伤。手指被喷嘴卡住可能会导致灼伤。 请穿戴不会裸露皮肤的衣服。</p>	
⚠ CAUTION	
<p>Bonding operation Touching hot parts may cause burns. Getting fingers caught by the nozzle may cause burns. Wear clothing that does not expose your skin.</p>	

(*1) Safety devices:

Front cover R, front cover L, rear cover R, rear cover L,
 pocket cover, side cover, nozzle lever front cover, nozzle lever rear cover, rubber cap 13,
 rubber cap 15.5, nozzle cover

(*2) Use protective gloves which can withstand temperatures of 200°C and higher.

2 NAMES OF MAJOR PARTS

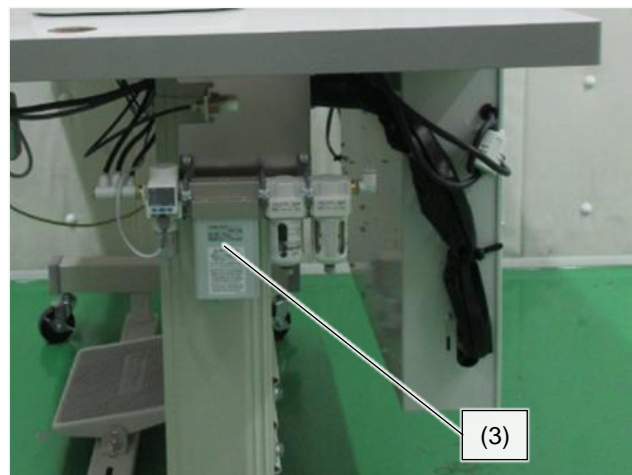
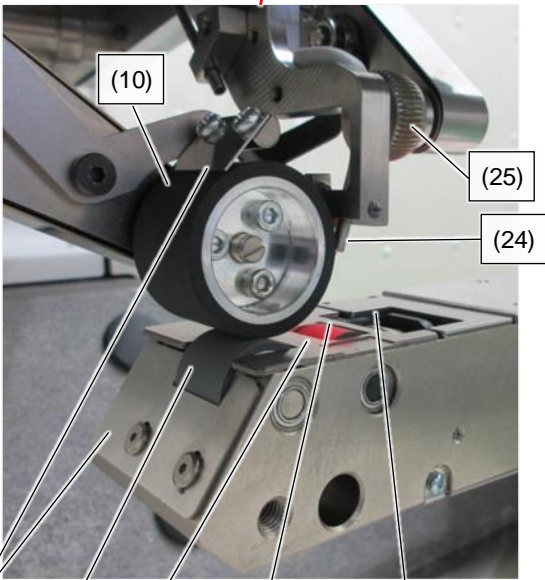
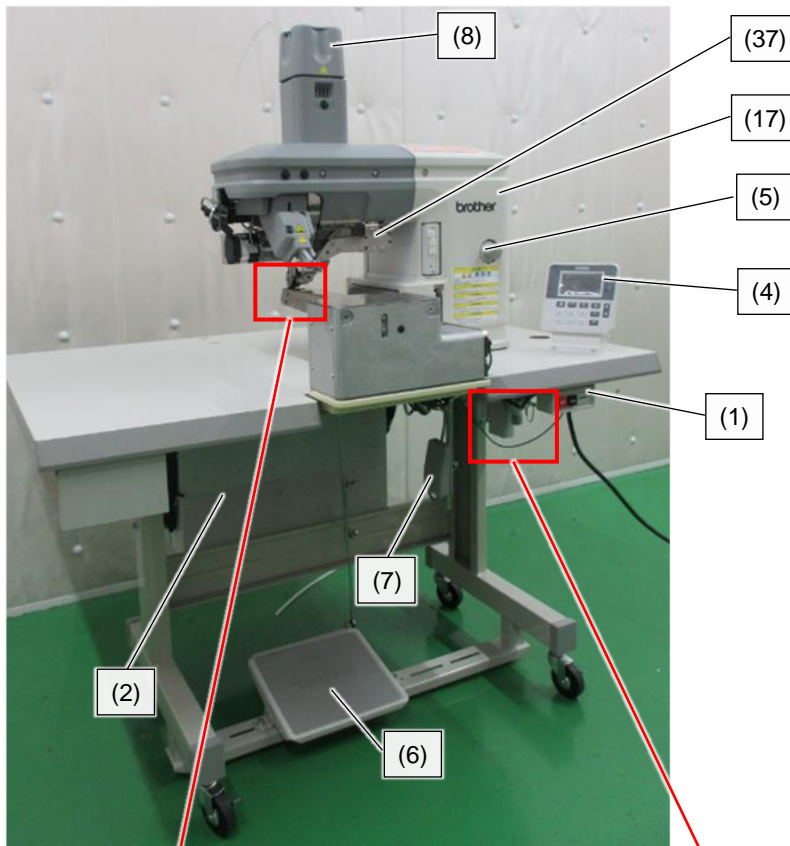

2 NAMES OF MAJOR PARTS

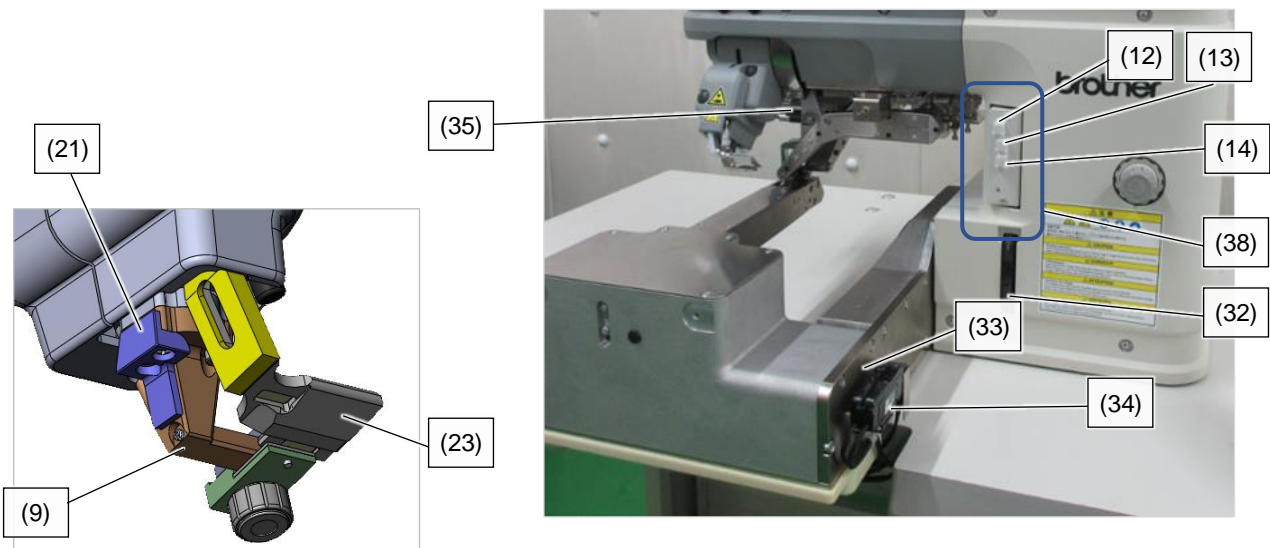
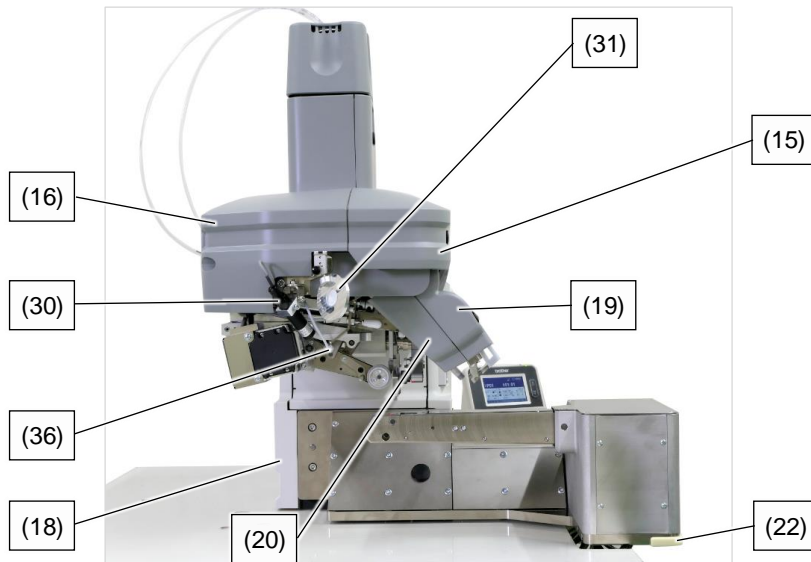

- | | | |
|---|--------------------------------|-------------------------------------|
| (1) Power switch | (13) GLUE ON/OFF switch | (26) Lower edge control roller |
| (2) Control box | (14) Op hand switch | (27) Roller under nozzle |
| (3) Air unit | (15) Front cover L | (28) Cloth plate |
| (4) Operation panel | (16) Rear cover L | (29) Anti-entanglement plate |
| (5) Upper roller pressure adjustment knob | (17) Front cover R | (30) Positioning LED marker |
| (6) Treadle | (18) Rear cover R | (31) Positioning mirror |
| (7) Knee switch | (19) Nozzle lever front cover | (32) Upper cloth sensor amplifier |
| (8) Melter cover | (20) Nozzle lever rear cover | (33) Lower cloth sensor amplifier |
| (9) Nozzle | (21) Nozzle cover | (34) End detection sensor amplifier |
| (10) Upper roller | (22) Frame bottom cover | (35) Nozzle light (front) |
| (11) Lower roller | (23) Upper cloth plate | (36) Nozzle light (back) |
| (12) NOZZLE switch | (24) Upper cloth sensor | (37) Feed speed adjustment switch |
| | (25) Upper edge control roller | (38) Hand switch |

3 USING THE OPERATION PANEL AND SWITCHES

3.1 Name and function of each operation panel item

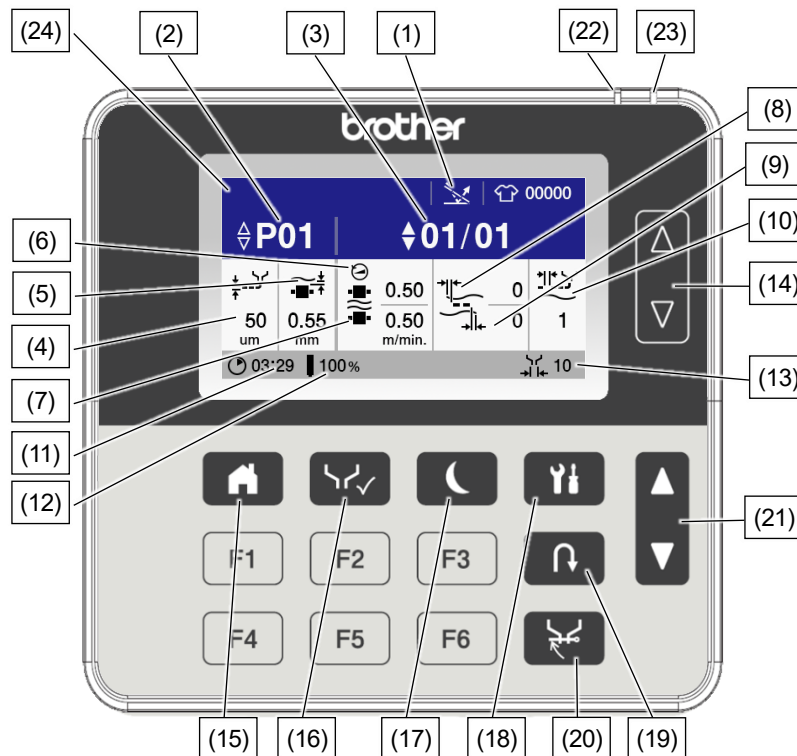

- | | |
|---|---|
| <p>(1) End detection sensor
Used to switch the end detection sensor between on and off.</p> <p>(2) Program number
Used to select programs.</p> <p>(3) Step No.
Used to select and edit steps.</p> <p>(4) Glue thickness
Used to set the glue thickness.</p> <p>(5) Nozzle space
Used to set the nozzle clearance.</p> <p>(6) Upper roller feed speed
Used to set the feed speed for the upper roller.</p> <p>(7) Lower roller feed speed
Used to set the feed speed for the lower roller.</p> <p>(8) Upper cloth glue-free width
Used to set the glue-free width for the upper cloth.</p> <p>(9) Lower cloth glue-free width
Used to set the glue-free width for the lower cloth.</p> <p>(10) Anti stop mark
Used to set anti-stop marks.</p> <p>(11) Glue heating time
Shows the total time required for heating a single glue cartridge.</p> <p>(12) Glue level
Shows the amount of glue remaining in the glue cartridge.</p> <p>(13) Nozzle glue width
Shows the gluing width for the nozzle which is currently attached.</p> | <p>(14) Change program No.
Used to increase or decrease the program number.</p> <p>(15) HOME key
Used to switch to the home screen.</p> <p>(16) Test key
Used to switch to test mode.</p> <p>(17) Sleep key
Used to switch manually to sleep mode. In addition, if it is held down while already in sleep mode, then sleep mode is canceled.</p> <p>(18) Menu key
Used to switch to the setting menu screen.</p> <p>(19) Reverse key
Used to switch to reverse mode.</p> <p>(20) Nozzle cap key
Used to switch to shutdown procedure.</p> <p>(21) Change step No. key
Used to increase or decrease the step number.</p> <p>(22) Caution indicator
Illuminates when an error or a warning occurs.</p> <p>(23) Power indicator
Illuminates when the power is turned on.</p> <p>(24) Comment
Shows program comments. In addition, touch it to set comments.</p> |
|---|---|

3.2 Program setting method

This registers programs with the settings that are required for gluing. After a program has been registered, it can be retrieved simply by selecting the program number.

- Thirty programs P01 to P30 can be set.
- Programs cannot be added or deleted.
- Each program consists of from 1 to 8 steps.
 - Steps can also be changed while gluing is in progress by pressing the knee switch.
 - At the time of shipment from the factory, each program is set to a single step.
 - Touch "Step No." on the operation panel screen to add and delete steps. Refer to "3.2.4 Step setting method" for details on the setting method.

1. Carry out either of the following operations at the home screen to select the program (P01 to P30) that you would like to change.

A) Press the  key (or the  key). The program No. increases (decreases) each time you press it once.

B) Touch "Program number" to display the program setting screen, and then touch the program you would like to select.

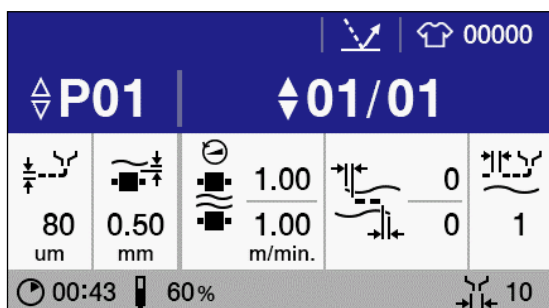
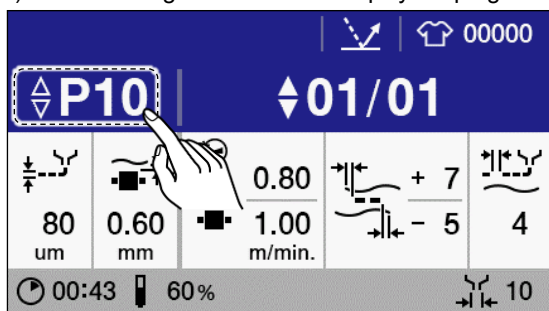

3.2.1 Parameter list

Some of the parameters are set once for each program (and are common to all steps in that program), and other parameters are set individually for each step.

[Program parameters]

Parameter	Setting range	Unit	Initial value
Glue thickness (Thickness of the glue)	50 - 200 [μm]	10 [μm]	80 [μm]
Nozzle space (Clearance between the nozzle and the roller under nozzle)	0.10 - 2.50 [mm]	0.05 [mm]	0.50 [mm]
Comment (Comment string for program which is displayed on the screen)	Up to 24 alphanumeric characters	--	Not input

[Step parameters]

Parameter	Setting range	Unit	Initial value
Upper roller feed speed	0.50 - 5.00 [m/min]	0.01 [m/min]	1.00 [m/min]
Lower roller feed speed	0.50 - 5.00 [m/min]	0.01 [m/min]	1.00 [m/min]
Upper cloth glue-free width	-50 - +50	1	0
Lower cloth glue-free width	-50 - +50	1	0
Anti stop mark	1 - 10	1	1

3.2.2 Glue thickness setting method

You can change the thickness of the glue which is being discharged from the nozzle.

1. Touch "Glue thickness" to display the glue thickness setting screen.

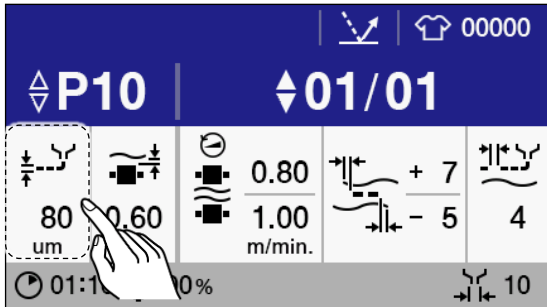

2. Touch the numeric keys, **+** or **-** to set the thickness of the glue.

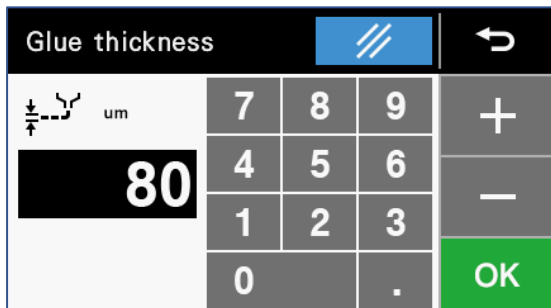

3. Once changing is complete, touch **OK** to confirm the changed setting and then return to the home screen. If you would like to cancel the setting change, touch **↩**.

3.2.3 Nozzle clearance setting method

You can change the clearance between the nozzle and the roller under nozzle.

1. When the nozzle is raised, press the NOZZLE switch to lower the nozzle to the lowest position.
2. Touch "Nozzle space" to display the nozzle space setting screen.

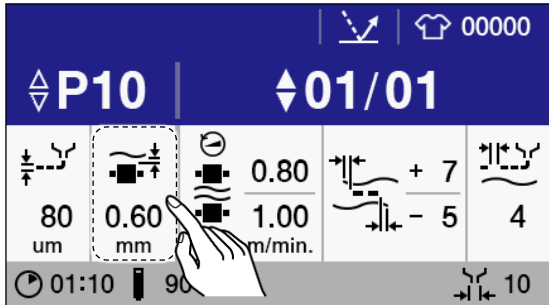

3. Touch **+** or **-** to set the nozzle space. When you change the numerical number on the operation panel, the clearance between the nozzle and roller under nozzle will change.

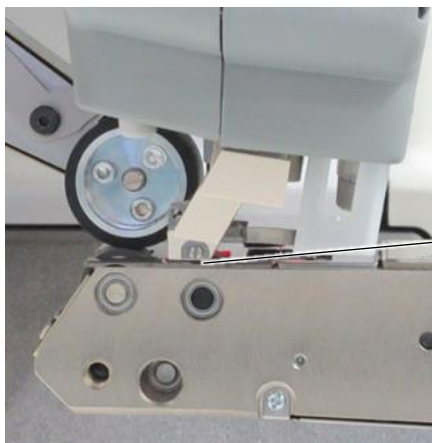
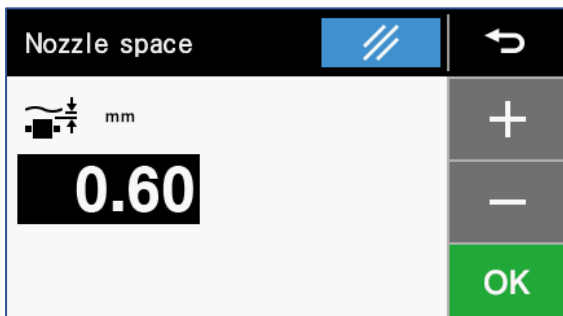



Nozzle space

4. Once changing is complete, touch **OK** to confirm the changed setting and then return to the home screen. If you would like to cancel the setting change, touch **↶**.

3.2.4 Step setting method

From 1 to 8 steps can be added to a single program. Different parameters can be set separately for each step. Steps can also be changed while gluing is in progress by pressing the knee switch. Adding/deleting and selecting steps can be carried out in the "Select/edit step" screen.

1. Select the program No. (P01 – 30) that you would like to change the setting for.
2. Carry out any one of the following operation to select the step No. (01 - 08) that you would like to change the setting for.
 - A) Press the  key or the  key. The step No. changes by one each time you press it once.
 - B) touch the step number to display the "Select/edit step" screen, select the step number, and then touch .

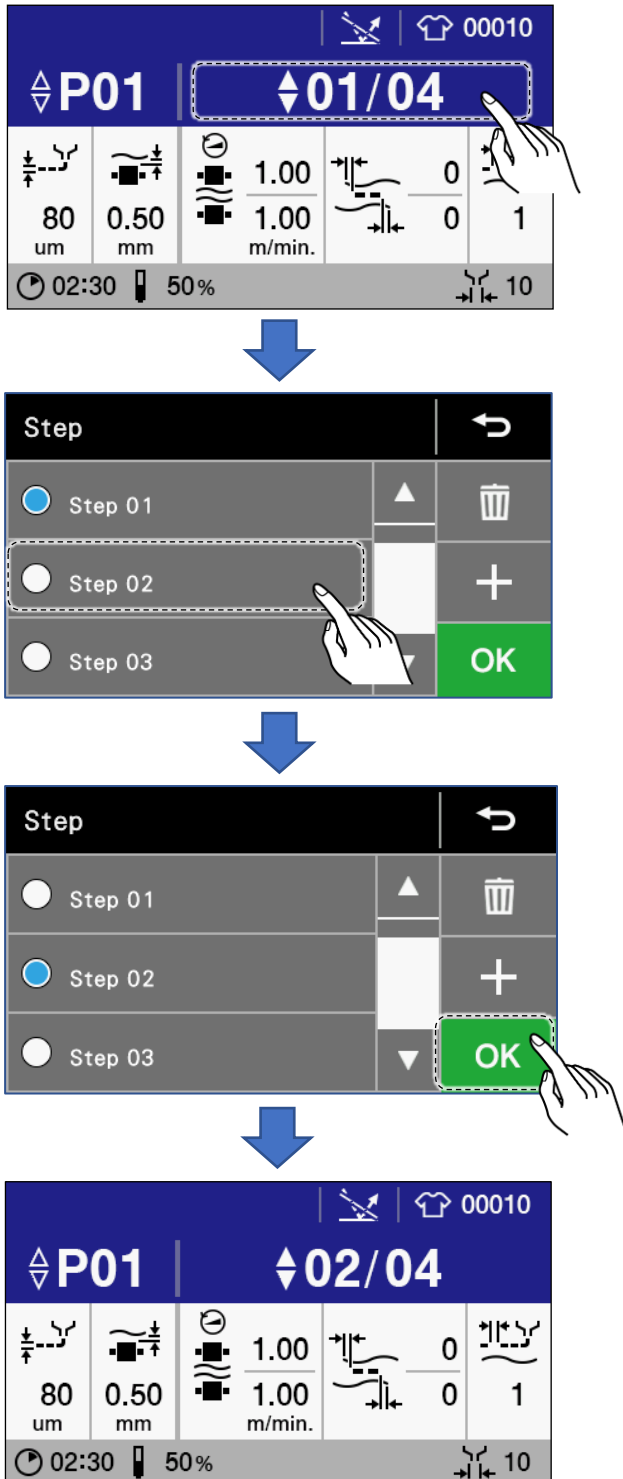

[Add/Delete step]

1. Touch the step No.

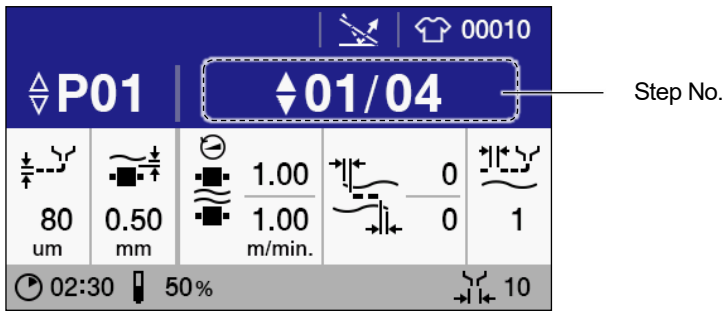

2. The "Select/edit step" screen will be displayed for you to add or delete steps.





[Add step]

- If you touch , a new step will be added between the currently-selected step and the following step.
- If there are already 8 steps, a new step cannot be added.

[Delete step]

- Touch  to delete the step which is currently selected.
- If there is only 1 step, that step cannot be deleted.

3. Once changing is complete, touch . If a step has been added or deleted, the following confirmation screen is displayed, so touch  once more to confirm the setting changes and then return to the home screen. If you would like to cancel the setting change, touch .

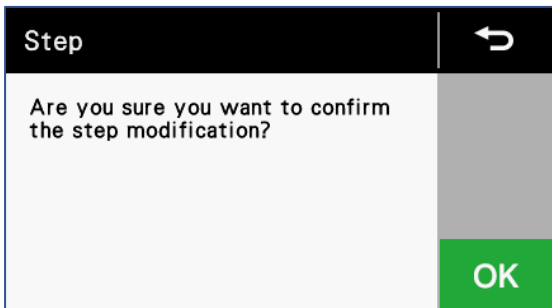

3 USING THE OPERATION PANEL AND SWITCHES

3.2.4.1 Upper and lower roller feed speed setting

You can change the feed speed of the upper roller and lower roller.

1. Touch "Upper roller feed speed" or "Lower roller feed speed" to display the roller feed speed screen.

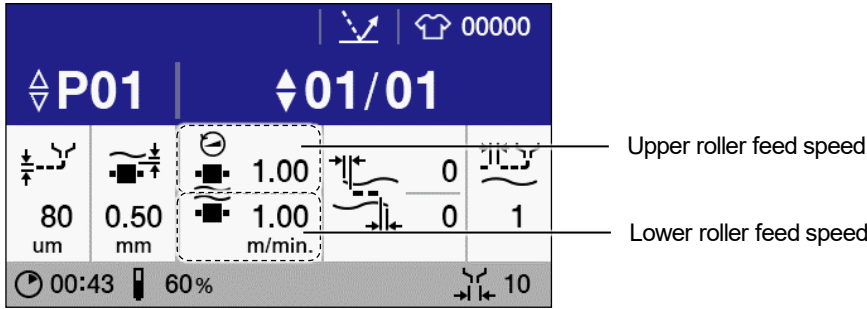

2. Touch the numeric keys, **+** or **-** to enter each of the feed speeds for the upper roller and lower roller. Places where white numbers are displayed on a black background are where the settings have been changed. The feed speeds for the upper roller and the lower roller can both be changed at the same time. To change a different setting, touch the place where the speed setting that you would like to change is displayed.

- Changing the upper roller feed speed

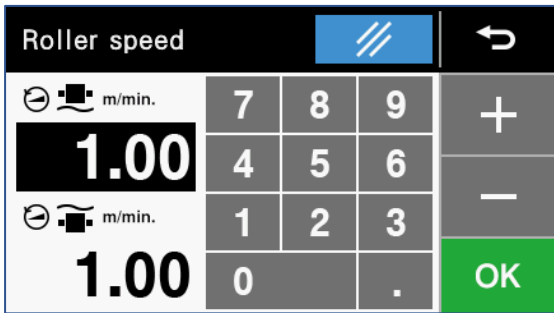

- Changing the lower roller feed speed

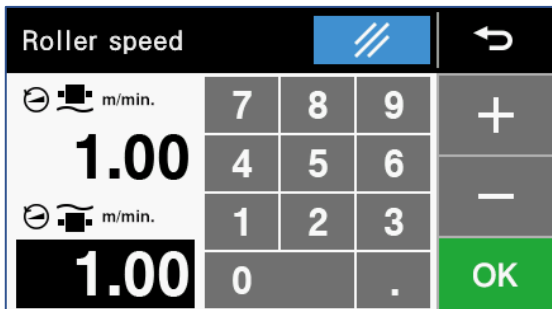

- Changing the upper and lower feed speed

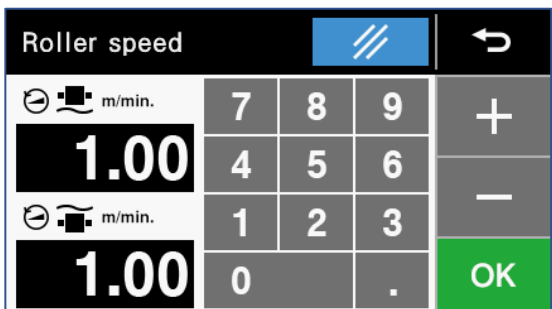

3. Once changing is complete, touch **OK** to confirm the changed setting and then return to the home screen. If you would like to cancel the setting change, touch **↩**.

3.2.4.2 Upper and lower cloth glue-free width setting

You can change glue-free width of upper cloth and lower cloth.

1. Touch “Upper cloth glue-free width” or “Lower cloth glue-free width” to display the glue-free width setting screen.

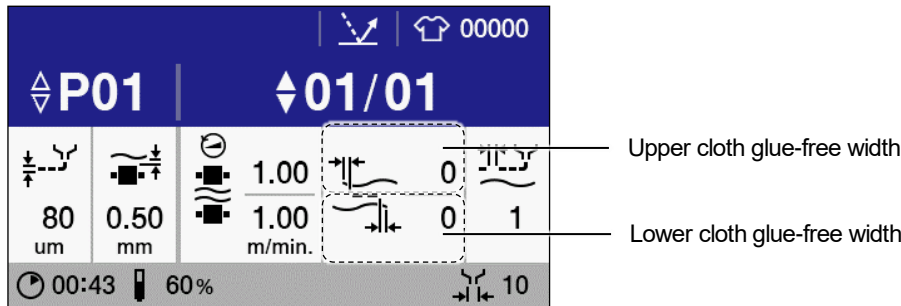

2. Touch the numeric keys, **+** or **-** to enter each of the glue-free widths for the upper cloth and lower cloth. Places where white numbers are displayed on a black background are where the settings have been changed. The glue-free widths for the upper cloth and the lower cloth can both be changed at the same time. To change a different setting, touch the place where the glue-free width that you would like to change is displayed.

- Changing the upper glue-free width



- Changing the lower glue-free width

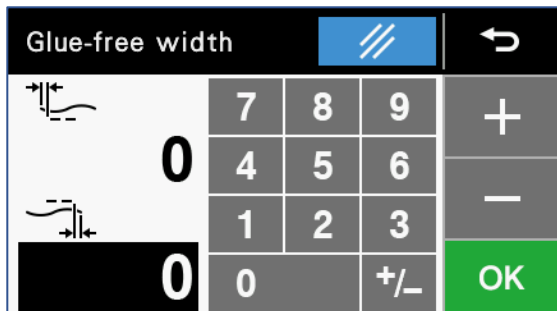

- Changing the upper and lower glue-free width



3. Once changing is complete, touch **OK** to confirm the changed setting and then return to the home screen. If you would like to cancel the setting change, touch **↩**.

3 USING THE OPERATION PANEL AND SWITCHES

3.2.4.3 Anti stop mark

Stop marks are places where the thickness of the glue being applied to the cloth is uneven, and they occur when glue application is intermittent (application --> pause --> application) .

To prevent stop marks from occurring, change the "Anti stop mark" setting. If the stretchability of the cloth changes, the optimum settings for glue application also change, so stop marks can be adjusted for different types of cloth.

In addition, in cases where the stretchability of the cloth varies in the horizontal direction and the vertical direction, set the adjustments separately for gluing in the horizontal direction and gluing in the vertical direction.

1. Touch "Anti stop mark" to display the anti stop mark setting screen.

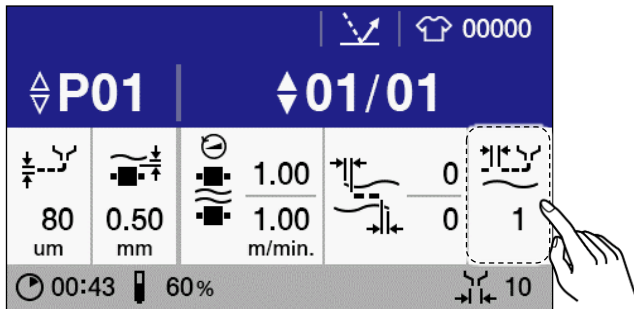

2. Touch **+** or **-** to change the parameter. The more stretchable the cloth is, the higher the value you should set.

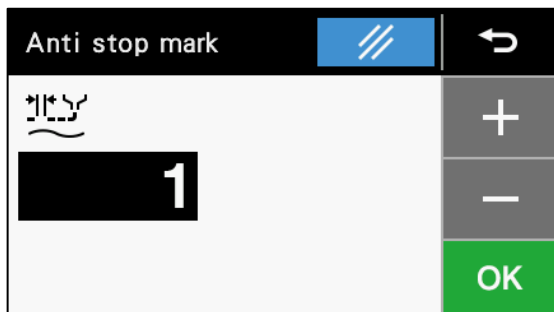

3. Once changing is complete, touch **OK** to confirm the changed setting and then return to the home screen. If you would like to cancel the setting change, touch **↶** .

3.2.5 Comment setting method

Comments can be set for each program. If you select a program which has a comment set, the comment is displayed in the top-left corner of the home screen.

1. Touch "Comment" to display the comment setting screen.
* The initial setting is for no comment to be entered.

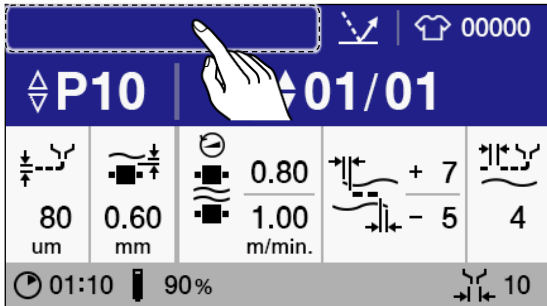

2. Use the keyboard on the operation panel to enter the comment.

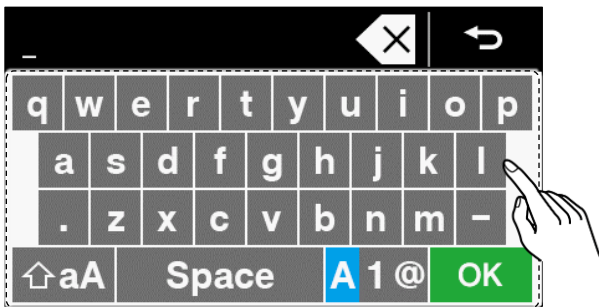

3. Once the comment has been entered, touch **OK** to return to the home screen. To delete the text which has been entered, touch **↵**.



4. The entered comment will be highlighted.

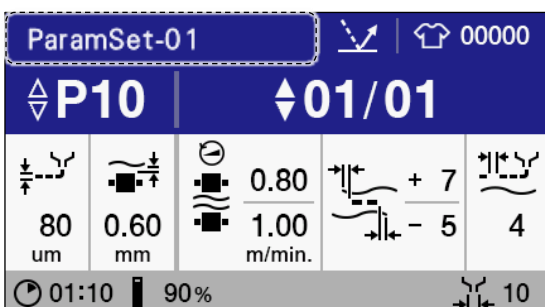

3.3 Using the switches

3.3.1 NOZZLE switch

When you press the NOZZLE switch, you can change the nozzle position.

When the NOZZLE switch is pressed, the indicator in the NOZZLE switch will illuminate and the nozzle will start to move.

When the nozzle stops moving, the indicator will turn off.

- * If you press the NOZZLE switch while the nozzle is moving, the nozzle will stop moving.
The indicator of the NOZZLE switch will blink at this time.
If you press the NOZZLE switch once more, the nozzle will return to its original position.

The movement position of the nozzle will be different depending on the panel screen.

- When the home screen is displayed or during reverse mode
If you press the NOZZLE switch when the nozzle is at its lowest position, the nozzle will move to a higher position.
If the nozzle is at a high position, it will move to the lowest position.
If the nozzle is at its highest position, it will move to a lower??? position.
- During test mode or when the end processing screen is displayed
If you press the NOZZLE switch when the nozzle is at an upward position, the nozzle will move to the highest.
If the nozzle is at its highest position, it will move to a lower??? position.
If the nozzle is at its lowest position, it will move to a higher position.

3.3.2 GLUE ON/OFF switch

The GLUE ON/OFF switch is used for turning the discharge of glue on and off when the treadle is operated.

When the indicator of the GLUE ON/OFF switch is turned off, glue cannot be discharged.

When it is illuminated, glue is discharged when the treadle is operated.

The operation method will be different depending on the panel screen.

- When the home window is displayed
If the treadle is operated once while the indicator is illuminated, the indicator will turn off.
If the treadle is operated once while the indicator is turned off, the indicator will illuminate.
- During test mode
The indicator will illuminate while the switch is being pressed.
When the switch is released, the indicator will turn off.

3.3.3 Knee switch and Op hand switch

The knee switch and Op hand switch are used for changing the program and step during a single process.

The functions of the knee switch and the Op hand switch can be changed by setting memory switch No. 231.

- When memory switch No. 231 is set to "1"
When the home screen is displayed, the step number is increased by 1 each time the knee switch is pressed.
The Op hand switch cannot be used.
- When memory switch No. 231 is set to "2"
When the home screen is displayed, the step number is increased by 1 each time the knee switch is pressed.
When the home screen is displayed and the treadle is at the neutral position, the program number is increased by 1 each time the Op hand switch is pressed.

- When memory switch No. 231 is set to "3"

When the home screen is displayed and the treadle is at the neutral position, the program number is increased by 1 each time the knee switch is pressed.

The Op hand switch cannot be used

3.3.4 Feed speed adjustment switch

This can be used to make fine adjustments to the feed speed for the upper roller while gluing is being carried out.

- When the feed speed adjustment switch is moved upward, the feed speed for the upper roller becomes faster than the program setting speed. Memory switch No. 256 can be used to set the rate at which the speed increases.
- When the feed speed adjustment switch is moved downward, the feed speed for the upper roller becomes slower than the program setting speed. Memory switch No. 255 can be used to set the rate at which the speed decreases.
- If you try to start gluing while the feed speed adjustment switch is at a setting other than the neutral position, an error will occur. When starting gluing, return the feed speed adjustment switch to the neutral position.

3.4 Sleep mode

During sleep mode, the temperature of the glue is lowered while gluing is not being carried out, in order to prevent the glue from deteriorating. Use sleep mode if you will not be using the bonding machine for a certain period of time.

The glue heating time is not incremented during sleep mode.

The available sleep mode consists of "automatic sleep mode" and "manual sleep mode".

NOTE:

- The nozzle and melter will remain at high temperatures even during sleep mode, so be careful not to get burns from them.
- If not using the bonding machine for 2 hours or more, carry out the gluing stop procedure in Chapter 7 in order to prevent the glue in the nozzle discharge holes from solidifying.

3.4.1 Auto sleep mode

When the home screen is displayed or during test mode, if the treadle is not operated or no keys on the operation panel are pressed for a certain period of time (initial value: 30 minutes), the bonding machine will automatically enter sleep mode. The time interval before automatically entering sleep mode can be changed using memory switch No. 302. In addition, memory switch No. 301 can also be used to set the bonding machine so that it does not automatically enter sleep mode at all. Refer to "3.5" for details on the memory switch setting method.

[Automatic sleep mode operation]

1. 1 minute before the bonding machine switches to automatic sleep mode, the following warning screen will be displayed on the operation panel and the warning indicator on the operation panel will blink. If any one of the keys on the the operation panel is pressed at this time, the operation of automatically entering sleep mode will be canceled and the screen display will return to what it was before the warning screen was displayed.

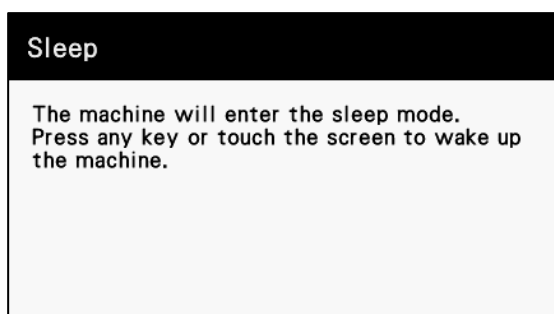

3 USING THE OPERATION PANEL AND SWITCHES

- If 1 more minute elapses without any operation being carried out, the bonding machine will enter sleep mode. The current temperatures for the melter, pump and nozzle will be displayed on the operation panel and the warning indicator will blink.

Sleep	
Melter (°C)	88.4
Pump (°C)	110.6
Nozzle (°C)	115.4

[Exiting automatic sleep mode]







- Press the  key for two seconds or more. The following temperature control screen will be displayed, so wait for approximately 10 minutes. (The waiting time will vary depending on the amount of time which has elapsed since sleep mode was entered.)

Temperature control	
Melter (°C)	88.1
Pump (°C)	109.4
Nozzle (°C)	114.3

- The panel display will switch as showed below. Wait for a further 5 minutes or so.

Temperature control	
Wait for a while	
4:10	

- The home screen will be displayed.

P10		01/01		0000	
 80 um	 0.60 mm	 0.80 1.00 m/min.	 + 7 - 5	 4	
01:10 90%		 10			

3.4.2 Manual sleep mode





If the length of interruption time from the moment when work is interrupted until it resumes can be estimated (such as when work begins again after a break), use manual sleep mode.

In manual sleep mode, you can set the amount of time before operation starts again, so that work can begin again straight away after sleep mode ends.

[Switching to manual sleep mode]

1. At the home screen, hold down the  key for two seconds or more.
2. The following screen will be displayed, the warning indicator will blink and the bonding machine will enter manual sleep mode. When the time that is displayed on the screen reaches "0:00", manual sleep mode is exited.

Sleep	
Melter (°C)	90.0
Pump (°C)	106.6
Nozzle (°C)	112.0
	42:41

3. To change the length of time before work is to resume (sleep time), press the  key. The display will change to the following screen, so touch  or  to change the time. To apply the changed setting, touch . If you would like to cancel the setting change, touch .

Sleep	
Set the sleep time	
	
45	

*The length of time can be set to 30, 45, 75, 90, 105 or 120 minutes.

[Interrupting manual sleep mode]

Carry out the same procedure as given in "Exiting automatic sleep mode" in "3.4.1 Auto sleep mode".

3.5 Memory switch

The functions of the operation panel include some that are set by memory switches at the time of shipment from the factory. You can change the settings for these memory switches if required. The settings for the memory switches are valid for all programs.

3.5.1 Memory switch setting method (for operators)

1. Press the  key to switch to the setting menu screen.
2. Touch "Memory SW".

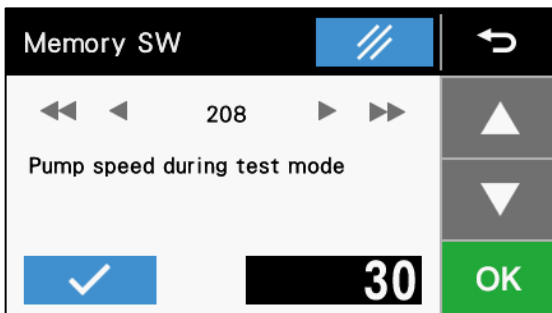
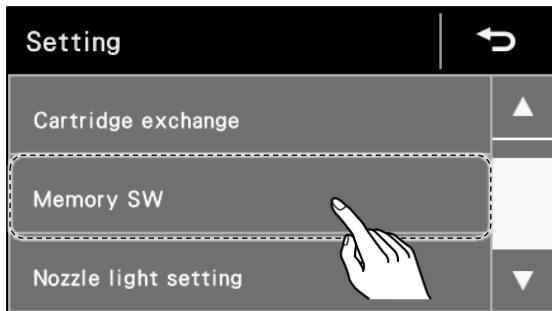

3.5.2 Memory switch setting method (for mechanics)

1. While pressing the  key, turn on the power switch to switch to the special menu screen.
2. Touch "Memory SW".

3.5.3 Memory switch setting method

1. Touch ◀ or ▶ to select a memory switch number that you would like to change the setting for. Touch ◀◀ or ▶▶ to search for and display only the memory switch that you would like to change from the initial value.

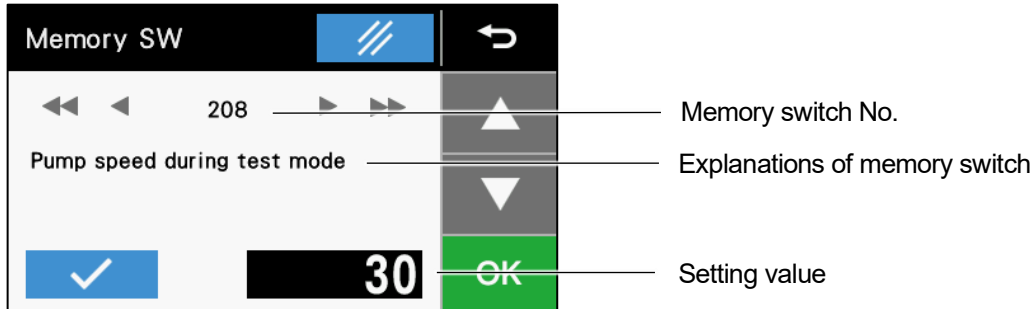

2. Touch ▲ or ▼ to change the setting value.
 - If the setting value is changed, it will start flashing. At this time, the setting has not yet been applied.
 - If you would like to return the setting to the initial value, touch the blue checkmark icon.
3. To display details for a memory switch number, touch the blue checkmark icon. At the details screen, touch the back arrow to return to the memory switch setting screen.

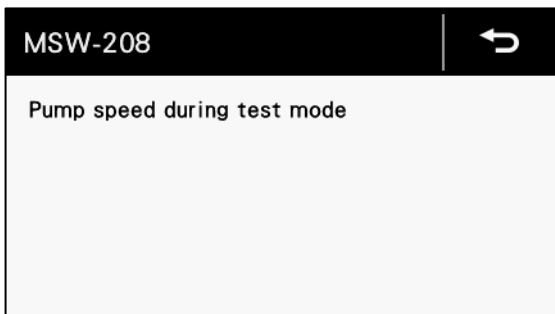

4. Once the operation is complete, touch the green 'OK' button to confirm the changed setting. When changed setting has been confirmed, the setting value display will change from blinking to illuminated. If you touch ◀, ▶, ◀◀ or ▶▶ without touching OK, the change will be canceled and a memory switch with a different number will be displayed. Touch XXX to cancel the setting change and return to the setting screen.
5. To change the settings for other memory switch numbers, repeat the operations in steps 2 to 3 above.

3.5.4 List of memory switch settings (for operators)

No.	Name	Setting	Setting range	Unit	Initial value
208	Pump speed during test mode	Pump speed during test mode	5 - 50 [rpm]	5	40
211	Automatic discharge time in test mode (F1)	Glue discharge time when F1 is pressed during test mode	10 - 1800 [s]	5	30
212	Automatic discharge time in test mode (F2)	Glue discharge time when F2 is pressed during test mode	10 - 1800 [s]	5	80
213	Automatic discharge time in test mode (F3)	Glue discharge time when F3 is pressed during test mode	10 - 1800 [s]	5	600
214	Automatic discharge time in test mode (F4)	Glue discharge time when F4 is pressed during test mode	10 - 1800 [s]	5	180
215	Automatic discharge time in test mode (F5)	Glue discharge time when F5 is pressed during test mode	10 - 1800 [s]	5	180
221	Assignment No. for F1 key	Program number selected when F1 is pressed at the home screen	OFF, 1 - 30	1	OFF
222	Assignment No. for F2 key	Program number selected when F2 is pressed at the home screen	OFF, 1 - 30	1	OFF
223	Assignment No. for F3 key	Program number selected when F3 is pressed at the home screen	OFF, 1 - 30	1	OFF
224	Assignment No. for F4 key	Program number selected when F4 is pressed at the home screen	OFF, 1 - 30	1	OFF
225	Assignment No. for F5 key	Program number selected when F5 is pressed at the home screen	OFF, 1 - 30	1	OFF
226	Assignment No. for F6 key	Program number selected when F6 is pressed at the home screen	OFF, 1 - 30	1	OFF
231	Program/Step changing method	1: Change step with knee switch 2: Change step with knee switch and change program with Op hand switch 3: Change program with knee switch	1 - 3	1	1
255	Feed speed decrease rate	Upper roller speed deceleration rate when feed speed adjustment switch is moved down	-10.0 - 0.0[%]	0.1	0.0
256	Feed speed increase rate	Upper roller speed acceleration rate when feed speed adjustment switch is moved up	0.0 - 10.0[%]	0.1	0.0
301	Auto sleep mode	Automatic sleep mode	OFF, ON	-	ON
302	Elapsed time before entering auto sleep mode	Standby time until automatic sleep mode is entered	15 - 60 [min]	15	30
400	Speed of edge control roller	Edge control roller rotation speed	10 - 300 [rpm]	10	50
401	Upper edge controller	Upper edge controller OFF: Disabled ON: Enabled	OFF, ON	-	ON
402	Lower edge controller	Lower edge controller OFF: Disabled ON: Enabled	OFF, ON	-	ON
411	Nozzle lever - Glue position adjustment	Adjustment value for glue position	-120 - 120	4	0
413	Nozzle lever	Nozzle lever motor speed	60 - 300 [rpm]	10	300
421	X-over bonding	X-over detection function ON: Enabled, OFF: Disabled	OFF, ON	-	OFF
422	Sensitivity of the X-over bonding detection sensor	X-over detection sensor sensitivity	0.5 - 2.0	0.1	1.0
424	X-over bonding - Cloth plate lowering amount	Distance that cloth plate is lowered when an X-over seam is detected (AUTO: Lowering amount = clearance setting value)	AUTO, 0.1 - 2.00 [mm]	0.02	AUTO
426	X-over detection - cloth plate lowering position correction	Correction distance for cloth plate lowering position when an X-over seam is detected	-11.0 - 20.0 [mm]	0.1	0.0

No.	Name	Setting	Setting range	Unit	Initial value
427	X-over detection - cloth plate raising position correction	Correction distance for cloth plate raising position when an X-over seam is detected	-11.0 - 20.0 [mm]	0.1	0.0
430	Lower material presser	Lower material presser OFF: Disabled ON: Enabled	OFF, ON	-	ON
500	Nozzle glue width	Gluing width of installed nozzle	6 - 10 [mm]	2	8
522	Operation when upper roller stops	Upper roller pressure after paused OFF: Pressure off ON: Pressure on	OFF, ON	-	OFF
531	Feeding amount after and detection	Feed amount after detecting lower material end (mm)	0.0 - 25.0 [mm]	0.5	0.0
532	Feed distance after gluing stops	Feed distance until feed stops after gluing stops OFF: Does not stop	OFF, 1 - 100[mm]	1	OFF
601	Warning level for low amount of glue	Amount of remaining glue for displaying warning dialog	1 - 5[%]	1	3

3.5.5 List of memory switch settings (for mechanism)

No.	Name	Setting	Setting range	Unit	Initial value
11	Treadle mode for bonding preparation	Selection of treadle operation method during preparation for gluing	1 - 2	1	2
86	Treadle – Number of speed steps	Number of steps in the variable speed range for the treadle	OFF, 2 - 30	1	20
250	Max. feed speed	Max. feed speed	0.5 - 5.0 [m/min]	0.1	5.0
252	Feed speed during reverse mode	Feed speed during reverse mode	0.5 - 5.0 [m/min]	0.1	1.0
273	Feed motor excitation while paused	Feed motor excitation status when stopped	OFF, ON	-	ON
274	Pump motor excitation while paused	Pump motor excitation status when stopped	OFF, ON	-	OFF
550	Target temperature for melter	Target temperature for melter	80 - 145[°C]	5	90
551	Target temperature for pump	Target temperature for pump	80 - 145[°C]	5	120
552	Target temperature for nozzle	Target temperature for nozzle	80 - 145[°C]	1	125
553	Max pump speed	Pump speed upper limit	5 - 50[rpm]	1	42
554	Time out for temperature control	Temperature control timeout time	10 - 60[min]	5	30
555	Wait duration after reaching target temperature	Wait time after target temperature is reached	3 - 15[min]	1	5
556	Wait time after cartridge replacement	Wait time after cartridge replacement	5 - 30[min]	1	15
560	Temperature of melter during sleep mode	Melter temperature during sleep mode	OFF, 60 - 145[°C]	5	70
561	Temperature of pump during sleep mode	Pump temperature during sleep mode	OFF, 60 - 145[°C]	5	60
562	Temperature of nozzle during sleep mode	Nozzle temperature during sleep mode	OFF, 60 - 145[°C]	1	80
565	Temperature of melter during boot	Melter temperature during startup	80 - 145[°C]	5	125
566	Minimum duration for melter heating during boot	Melter heating time lower limit value during startup	10 - 60[min]	1	15
571	Minimum melter pressure	Melter pressurization lower limit	100 - 200 [KPa]	10	100
572	Maximum melter pressure	Melter pressurization upper limit	200 - 300 [KPa]	10	300

3 USING THE OPERATION PANEL AND SWITCHES





No.	Name	Setting	Setting range	Unit	Initial value
573	Minimum upper roller pressure	Upper roller pressure lower limit	1 - 60[N]	1	3
574	Maximum upper roller pressure	Upper roller pressure upper limit	1 - 60[N]	1	20
575	Minimum pump pressure	Pump pressure lower limit	0.00 - 0.10 [MPa]	0.01	0.00
576	Maximum pump pressure	Pump pressure upper limit	1.00~3.00 [MPa]	0.10	2.50
596	Nozzle position confirmation	Glue discharge when the nozzle is raised when gluing starts. ON: Not discharged, OFF: Discharged	OFF, ON	-	ON
650	Time duration until the buzzer stops	OFF: Buzzer does not stop	OFF 5 - 15[s]	5	OFF
652	Maximum duration of continuous bonding	OFF: Disabled 1 - 30: If bonding time exceeds the maximum value, it will be paused and error occurs.	OFF, 1 - 30[min]	1	3
759	Time duration until closing cartridge valve	Time until the cartridge valve is closed	0.1 - 10.0[s]	0.1	5.0
850	Language	Language setting 0: English 1: Japanese 2: Chinses	0 - 3	1	-
865	Upper roller lift up during reverse mode	Lift up the upper roller during reverse mode.	OFF, ON	-	ON

3.6 Nozzle light setting method

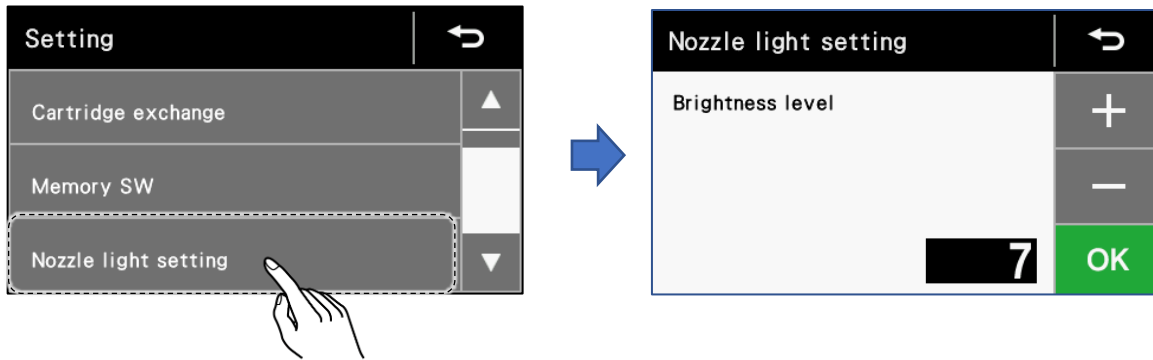
The brightness of the nozzle illumination can be set.

1. Press the  key to display the setting menu.
2. Touch "Nozzle light setting" to display the nozzle light setting screen.



3. Touch  or  to change the brightness of the nozzle illumination.
 - To apply the changed setting, touch .
 - If you would like to cancel the setting change, touch .
 - The brightness level can be set to a value from "0" to "9".
 - When a larger value is set, the illumination becomes brighter. When set to "0", the illumination turns off.

4 PREPARING THE GLUE

WARNING



Wear protective goggles when operating the bonding machine to avoid getting any glue into your eyes.



Furthermore, avoid getting the glue onto your skin. If this is not observed, problems such as burns, inflammation or allergic reactions could result.



Avoid drinking, eating and smoking while using the glue.

If the glue is accidentally ingested, problems such as respiratory difficulties or allergic reactions could result.



Be careful not to get any of the glue which has been applied to the cloth into your eyes or onto your skin.

If this is not observed, problems such as inflammation or allergic reactions could result.



Do not immerse the bonding machine in liquid. In addition, do not place objects on top of the bonding machine. If the contents of cups or other objects containing liquids spill onto the bonding machine, fire, electric shocks or problems with operation could result. If any liquid gets into the bonding machine (including the machine head and control box), immediately turn off the power switch, disconnect the power plug.



CAUTION



Attach all safety devices before using the bonding machine.



If the bonding machine is used without these devices attached, burns or injury may result.



If using a table which has casters, the casters should be secured in such a way so that they cannot move.



Do not touch the nozzle while using or after using the bonding machine. The nozzle becomes hot during use, and burns may result.



If there is a chance that you may touch the nozzle, be sure to wear protective gloves ^(*1).



Do not open the melter cover except when replacing the glue cartridge.



The equipment inside the melter cover, the melter, the glue cartridge and the cartridge valve become hot during use and may cause burns if touched.



Do not touch any of the moving parts or press any objects against the machine while using the bonding machine, as this may result in injury or damage to the bonding machine.



If an error occurs in machine operation, or if abnormal noises or smells are noticed, immediately turn off the power switch.

(*1) Use protective gloves which can withstand temperatures of 200°C and higher.

Flow of gluing

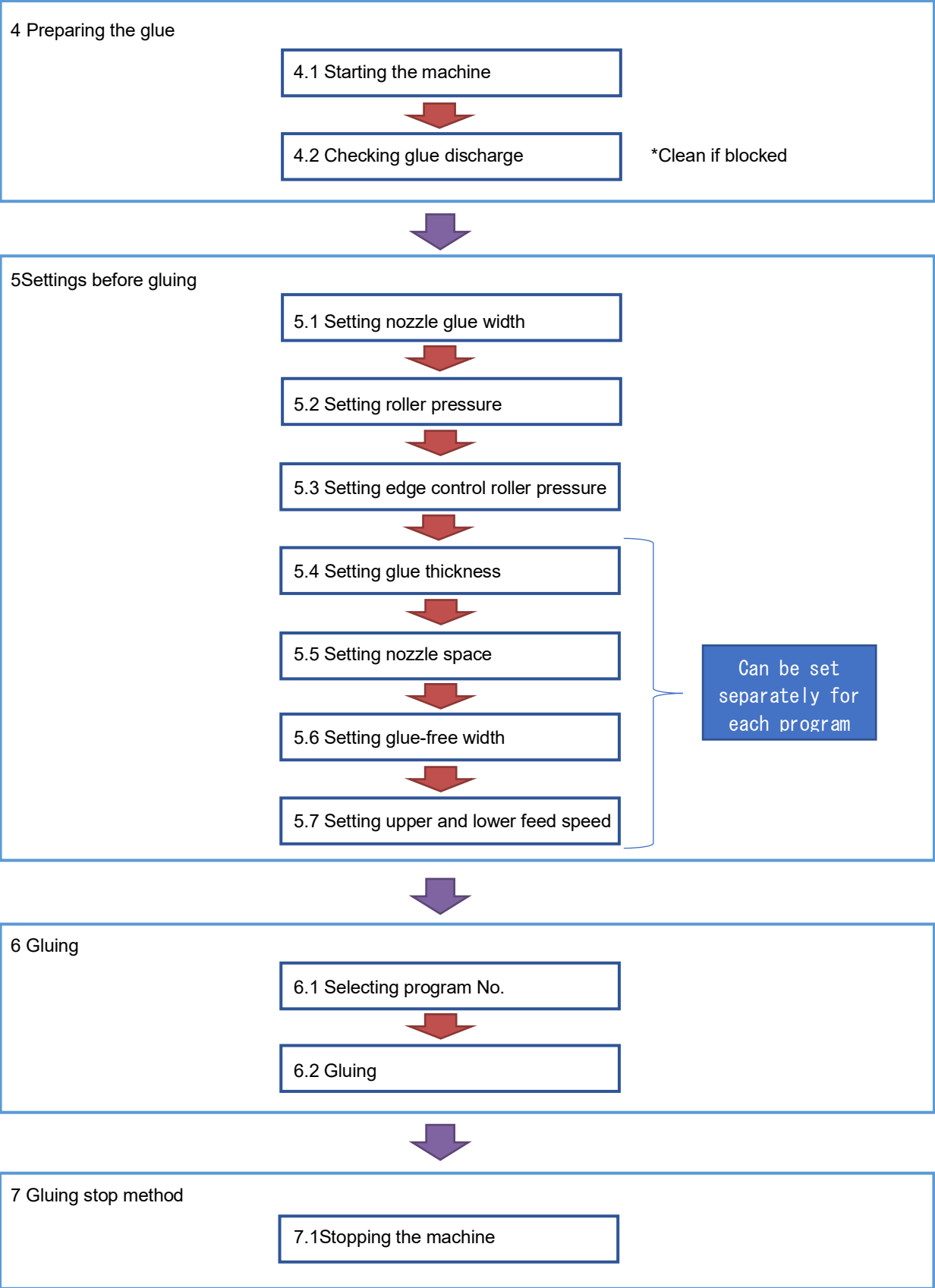

4.1 Starting the machine

1. Supply air to the air unit.
2. Turn on the power switch.
3. Wait until the "Remove the nozzle cap" message is displayed. Furthermore, the panel display will switch as showed below.

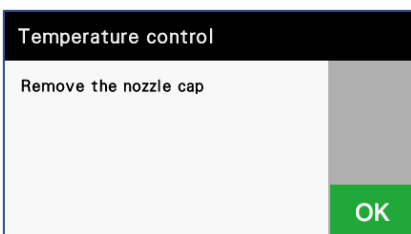
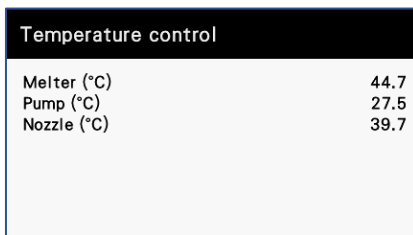

4. Remove the nozzle cap. The nozzle and the nozzle cap are hot, so be sure to wear protective gloves when removing the nozzle cap.
5. Touch .

6. The panel display will switch as showed below. Wait for a further 5 minutes or so.

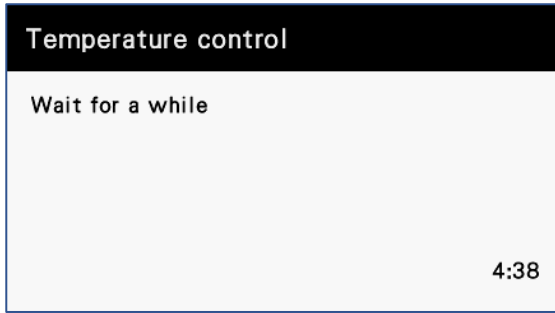

7. The following screen appears and touch **OK**. Home position detection for the nozzle will be carried out.

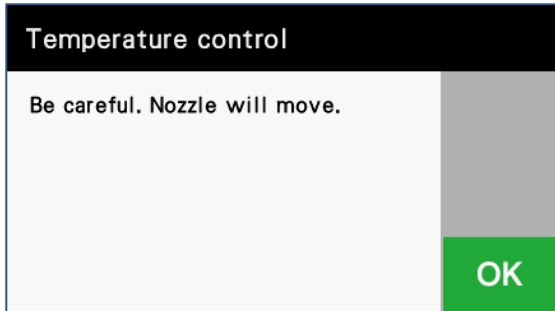

8. The home screen will be displayed.

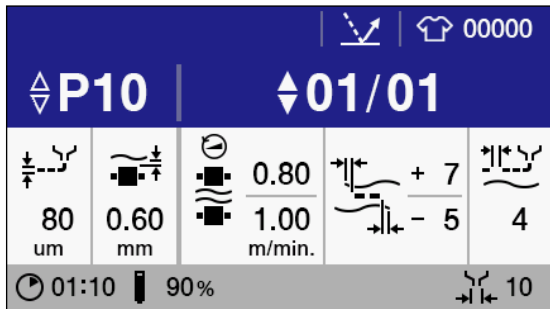

4.2 Checking glue discharge

1. Follow the method described below to discharge the glue in order to check that the glue is being discharged from the nozzle holes.

NOTE: Glue must be discharged from all of the nozzle holes.

2. If there are any problems with the discharge of the glue, carry out the procedure in 9.2 to clean the nozzle discharge holes.

4.2.1 Manual discharge mode

1. Press the  key to display the test screen.

Temperature and pressure		↩
Melter (°C)	89.6	
Pump (°C)	120.0	
Nozzle (°C)	124.8	
Melter pressure (kPa)	262	
Pump pressure (MPa)	0.28	
Upper roller pressure (N)	15.6	
	0:00	

* If the temperature or the pressure is outside the normal range, the value will be displayed in highlight as shown below.





Temperature and pressure		↩
Melter (°C)	125.0	
Pump (°C)	120.2	
Nozzle (°C)	125.1	
Melter pressure (kPa)	258	
Pump pressure (MPa)	0.35	
Upper roller pressure (N)	15.4	
	0:00	

2. Press the NOZZLE switch to raise the nozzle.
3. Use a cloth or similar to wipe the nozzle off.
4. Place something such as a dish or a cloth underneath the nozzle to prevent any glue from dripping onto the table.
5. While pressing the GLUE ON/OFF switch, depress the treadle to discharge the glue.

At this time, check that glue is being discharged from all of the discharge holes in the nozzle, and that there are no air bubbles in the glue.

- Once discharging of glue starts, it will continue even if you remove your hand from the GLUE ON/OFF switch.
- If there are any problems with the discharge of the glue, carry out the procedure in 9.2 to clean the nozzle discharge holes.

6. Press the  key to return to the home screen.

P10 01/01				
				
80 um	0.60 mm	0.80 1.00 m/min.	+ 7 - 5	4
01:10	90%			10

4.2.2 Automatic discharge mode

When the treadle is depressed once, discharge of glue will continue for a fixed length of time.

1. Carry out the same operation as give in 4.2.1.
2. Press one of the **F1**, **F2**, **F3**, **F4** or **F5** keys. "AUTO" will be displayed on the screen to indicate that automatic discharge mode is active, and the discharge time which has been assigned to the key which was pressed will be displayed.
(If the same key is pressed again, the "AUTO" characters will disappear and the mode will return to manual discharge mode.)

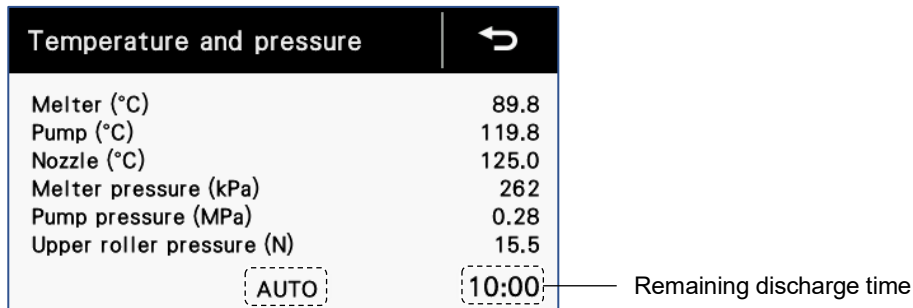

The discharge times which are assigned to each key can be set using the memory switches. Following is a list of the initial values.

Refer to "3.5" for details on the memory switch setting method.

Key	Expected use	Initial value	Corresponding memory switch No.
F1	Normal discharge check	0:30 (30 sec.)	211
F2	Discharge after cartridge replacement (Glue ⇒ Glue)	1:20 (80 sec.)	212
F3	Discharge after cartridge replacement (Glue ⇒ Cleaner)	10:00 (600 sec.)	213
F4	Discharge after cartridge replacement (Cleaner⇒ Glue)	3:00 (180 sec.)	214
F5	Measuring glue discharge amount	3:00 (180 sec.)	215

3. If the treadle is depressed while the GLUE ON/OFF switch is being pressed, glue will be discharged from the nozzle. Glue will continue to be discharged until the remaining discharge time reaches "0:00", even if the treadle is released at this time. To stop the discharge of glue before the time has ended, depress the treadle forward again or depress it backward.
4. After discharging has completed, clean the nozzle with a cloth or similar.
5. Press the  key to return to the home screen.

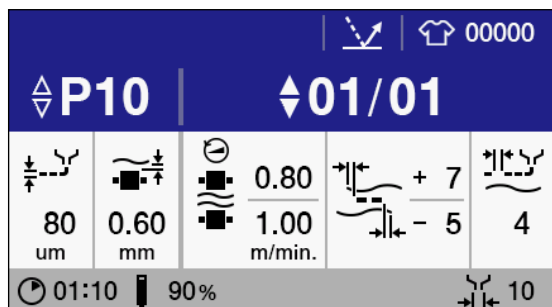

5 Gluing pre-condition setting method

WARNING



Wear protective goggles when operating the bonding machine to avoid getting any glue into your eyes.



Furthermore, avoid getting the glue onto your skin. If this is not observed, problems such as burns, inflammation or allergic reactions could result.



Avoid drinking, eating and smoking while using the glue.

If the glue is accidentally ingested, problems such as respiratory difficulties or allergic reactions could result.



Be careful not to get any of the glue which has been applied to the cloth into your eyes or onto your skin.

If this is not observed, problems such as inflammation or allergic reactions could result.



Do not immerse the bonding machine in liquid.



In addition, do not place objects on top of the bonding machine. If the contents of cups or other objects containing liquids spill onto the bonding machine, fire, electric shocks or problems with operation could result. If any liquid gets into the bonding machine (including the machine head and control box), immediately turn off the power switch, disconnect the power plug.



CAUTION



Attach all safety devices before using the bonding machine.



If the bonding machine is used without these devices attached, burns or injury may result.



If using a table which has casters, the casters should be secured in such a way so that they cannot move.



Do not touch the nozzle while using or after using the bonding machine. The nozzle becomes hot during use, and burns may result.



If there is a chance that you may touch the nozzle, be sure to wear protective gloves ^(*).



Do not open the melter cover except when replacing the glue cartridge.



The equipment inside the melter cover, the melter, the glue cartridge and the cartridge valve become hot during use and may cause burns if touched.



Do not touch any of the moving parts or press any objects against the machine while using the bonding machine, as this may result in injury or damage to the bonding machine.



If an error occurs in machine operation, or if abnormal noises or smells are noticed, immediately turn off the power switch.

(*1) Use protective gloves which can withstand temperatures of 200°C and higher.

5.1 Setting nozzle glue width

Check that the gluing width of the nozzle which is installed to the bonding machine matches the nozzle gluing width setting on the panel.

Set the gluing width to 6 mm, 8 mm or 10 mm depending on the specifications.

If changing the gluing width, replace the nozzle.

Refer to "11.1" for details on replacing the nozzle.

In addition, refer to "12.1 Changing the gluing width" when carrying out the various adjustments.

5.2 Setting roller pressure

Changing the roller pressure

You can change the pressure of the upper roller which presses the upper cloth and the lower cloth together.

The pressure which can be used is from 5 N to 15 N. The initial value is 10N. Adjust it if required.

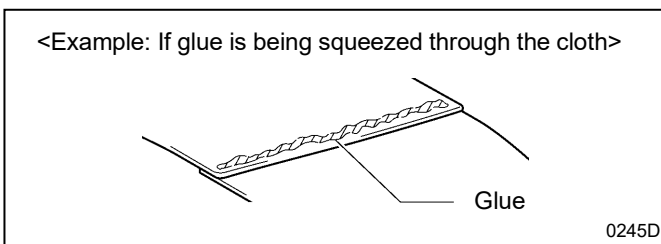

<If the upper roller pressure is too strong>

Glue will be squeezed through the cloth.

In addition, puckering can easily occur.

(Particularly at curved sections)

Adjust the upper roller pressure to a weaker setting.

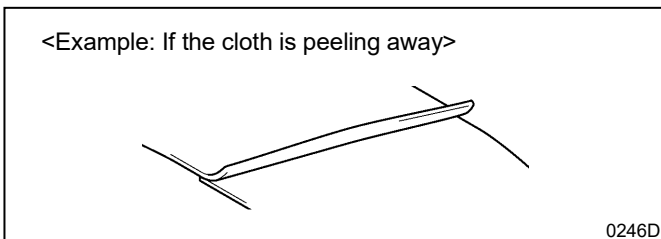



<If the upper roller pressure is too weak>

The cloth being glued will peel away.

In addition, the strength after gluing may become weaker.

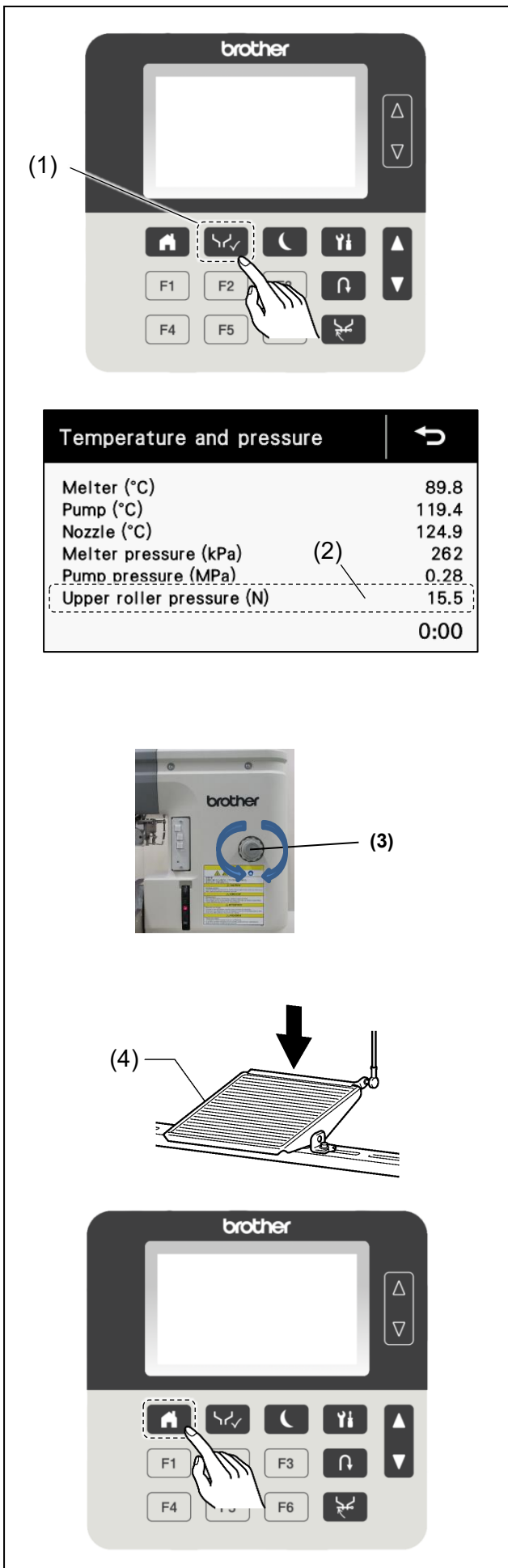
Adjust the upper roller pressure to a stronger setting.



1. Press the  key (1) to switch to the test mode.
2. Check the upper roller pressure display (2) in the test mode screen.
3. Depress the treadle (4).
4. Pull up the upper roller pressure adjustment knob (3) on a front side of the machine.
5. Turn the upper roller pressure adjustment knob (3) to adjust the upper roller pressure to the value that you would like to set.
* Adjust while checking the value in the operation panel.
6. Press the treadle (4) several times.
7. Check the value for the upper roller pressure display (2) in the operation panel with the treadle depressed.
* If the value is not at the target value, repeat the adjustment.
8. Push the upper roller pressure adjustment knob (3).
9. Return the screen to the home screen.

5.3 Setting edge control roller pressure

Changing edge control roller pressure

The pressure of the edge control rollers which controls the edge of the cloth can be changed.

* When gluing a cloth which the edge control rollers slide over easily, increase the pressure of the edge control rollers. Puckering can easily occur when using stretch cloth, so return the value to the setting at the time of shipment from the factory.

1. Make the pressure of the upper edge control roller stronger than the value at the time of shipment from the factory.
 - (1) Use a spanner to loosen the nut A, and turn it until is at the same position as the right-hand edge of the thread.

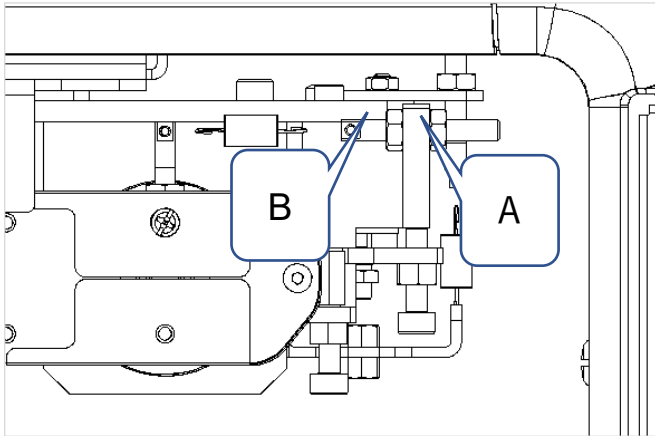

- (2) Turn the nut B all the way to the right, and then use a spanner to tighten it.

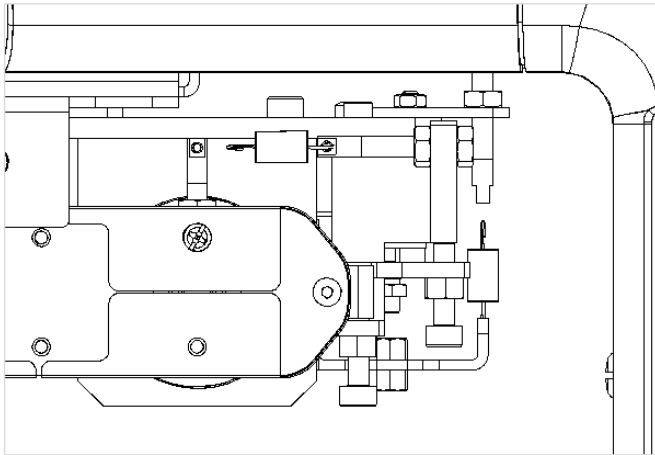

2. Make the pressure of the lower edge control roller stronger than the value at the time of shipment from the factory.

(1) Use a tool (Allen key with 2.5 mm width across flats) to loosen the two bolts C.

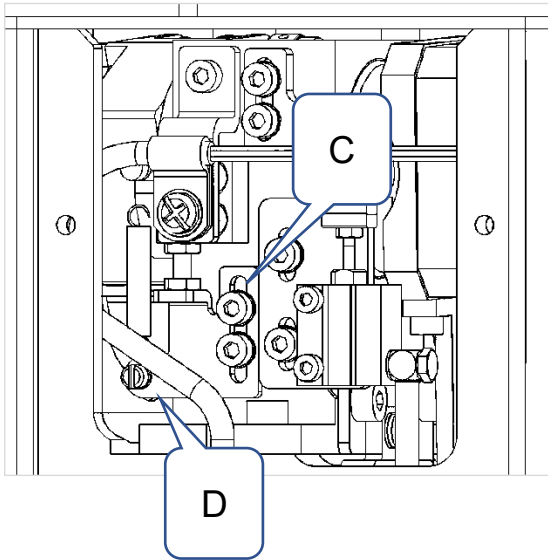

(2) Lower the plate D which is secured by a spring to its lowest position.

(3) Tighten the two bolts which were loosened in step 1.

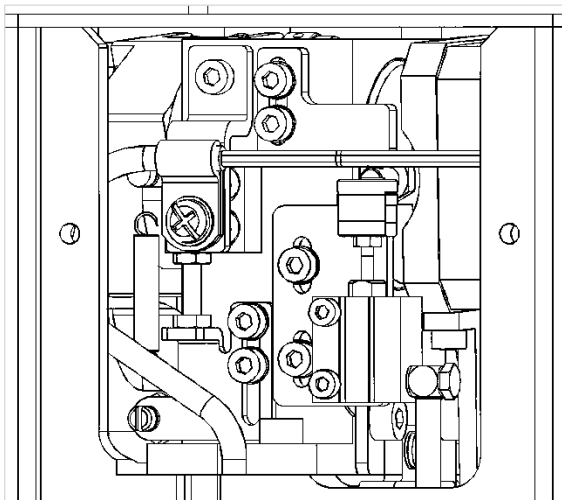

5.4 Setting glue thickness

Set the thickness to match the cloth being glued.

When the thickness of the glue is increased, the adhesion force increases, but the area being glued will tend to become stiffer.

1. At the home screen, select the program number that you would like to change.

The display will change.

The thickness can be adjusted to between 50 μm and 200 μm .

The initial value is 80 μm .

Adjust it if required.

- If the glue is too thin, peeling will occur (because of insufficient adhesion strength), and if the application is done poorly or the glue is too thick, the glue may seep out and protrude from the cloth.

Glue thickness changing method

Refer to "3.2.2 Glue thickness setting method" for details on setting the glue thickness.

5.5 Setting nozzle space

Set the clearance between the nozzle and nozzle lower roller in accordance with the thickness of the cloth being glued. Set the nozzle clearance to the smallest value so that there is no resistance when the cloth is moved back and forth.

Example 1: If nozzle space is too large

The glue application will become uneven.

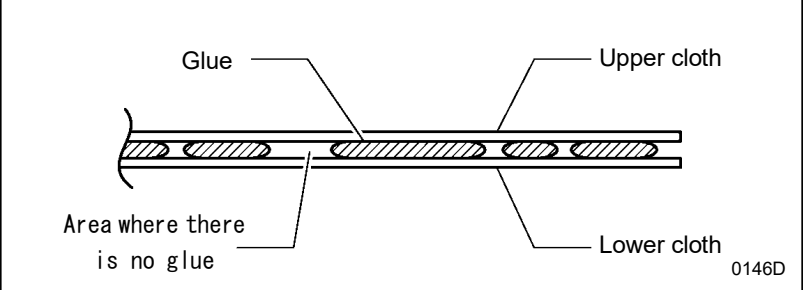

Example 2: If nozzle space is too small

Upper cloth and lower cloth are uneven.

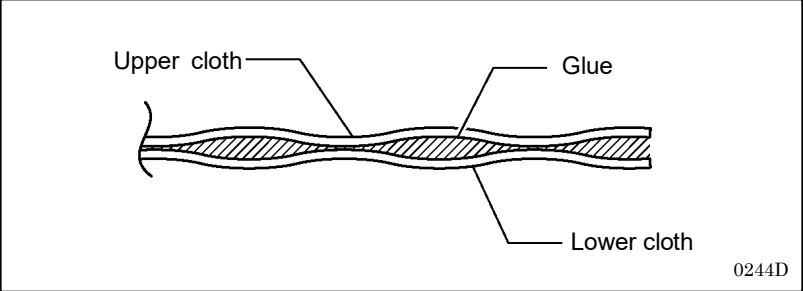

Nozzle space setting method

1. If glue adheres to the bottom of the nozzle or around the cloth plate, clean it off.
2. Set the clearance between the nozzle and the cloth so that it is wider (as a guide: cloth thickness + 0.3 mm) and pass the cloth underneath.
3. Move the cloth back and forth and check that there is no resistance.
4. Make the nozzle clearance one step (0.05 mm) narrower, and then move the cloth and check that there is no resistance.
5. Keep repeating step 4 and if you feel resistance, increase the nozzle clearance by 1 step. The optimum nozzle clearance will then be obtained.

Refer to "3.2.3 Nozzle clearance setting method" for details on panel operations.

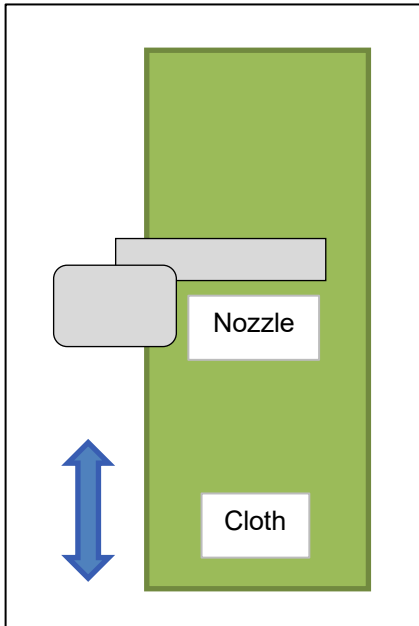
**5.6 Setting glue-free width**

Set the glue-free width for the upper cloth and the lower cloth to match the type of cloth being glued.

If the type of cloth being glued changes, this will need to be readjusted.

The glue-free width may vary depending on the gluing direction and color of the cloth.

NOTE :

If the gluing width is not adjusted, the glue may protrude from the edge of the cloth, and the cloth may become attached to the rollers, so be sure to make this setting so that the glue does not protrude.

Glue-free width setting method for upper cloth and lower cloth

Set the glue-free width for the upper cloth and lower cloth while referring to "3.2.4.2 Upper and lower cloth glue-free width setting".

The settings can be made separately for the upper cloth and the lower cloth.

The settings can be made within the range of -50 to +50.

* The setting value is an index value, and does not represent the actual length.

- If you would like to make distances A and B (glue-free widths) as shown in the illustration below larger, then increase the values; if you would like to make them smaller, decrease the values.

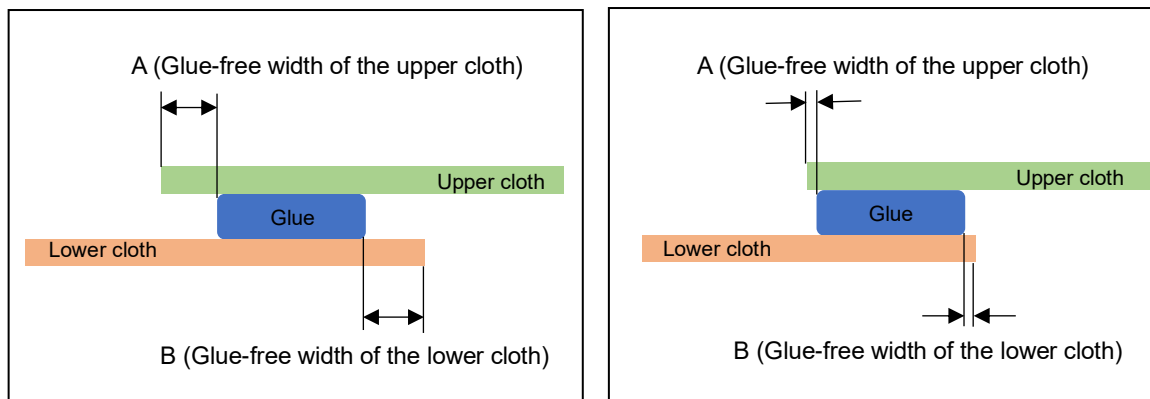

5.7 Setting upper and lower feed speed

The optimum value for the ratio between the feed speeds for the upper roller and the lower roller will vary depending on conditions such as the type of cloth, the gluing direction, the feed speeds and the gluing thickness.

Therefore, set the upper and lower feed speeds according to the gluing conditions.

Upper and lower feed speed setting method

1. Set lower feed speed.

They can be set within the range of 0.5 m/min to 5 m/min.

Adjust it if required.

2. Set upper feed speed.

Basically the settings should be made as follows.

Cut a piece of cloth which is made from the same material as the gluing pattern into strips (recommended size: 300 mm long x 40 mm wide).

At this time, the direction of the cloth should be the same as the respective patterns for the upper cloth and lower cloth.

Glue this cloth, and check the difference in length between the trailing ends of the upper cloth and lower cloth.

Refer to "3.2.4.1 Upper and lower roller feed speed setting" for panel operations.

Example 1: If the trailing end of the upper cloth is longer

The feed speed of the upper roller is too slow with respect to the feed speed of the lower roller.
Increase the feed speed of the upper roller.

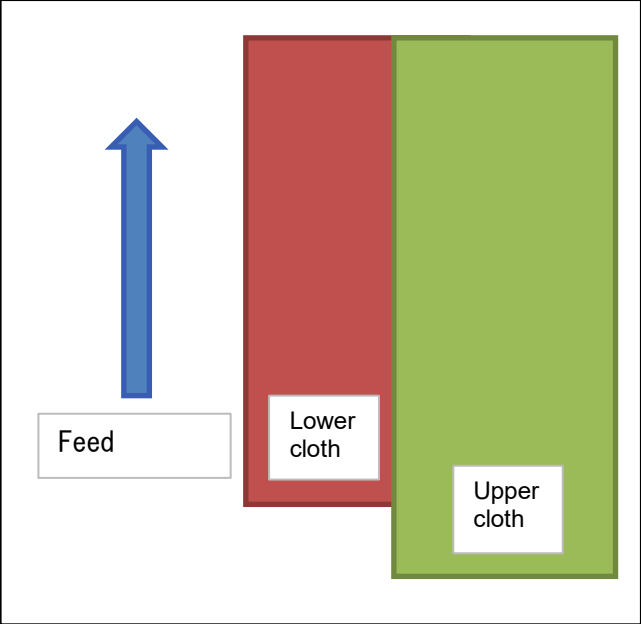

Example 2: If the trailing end of the lower cloth is longer

The feed speed of the lower roller is too slow with respect to the feed speed of the upper roller.
Reduce the feed speed of the lower roller.

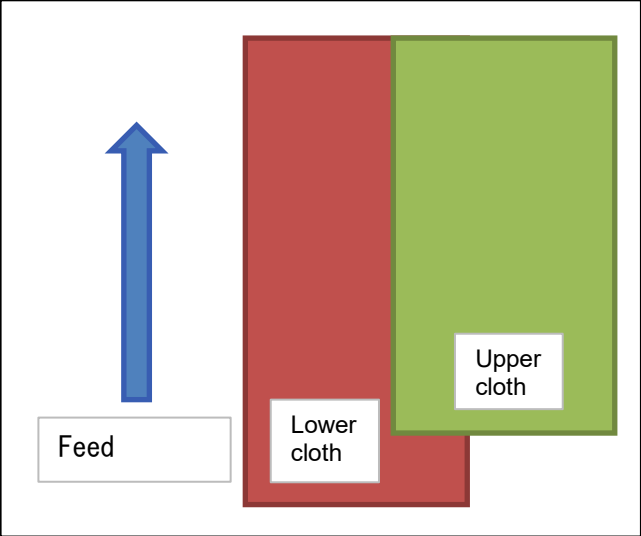

6 GLUING

WARNING



Wear protective goggles when operating the bonding machine to avoid getting any glue into your eyes.



Furthermore, avoid getting the glue onto your skin. If this is not observed, problems such as burns, inflammation or allergic reactions could result.



Avoid drinking, eating and smoking while using the glue.

If the glue is accidentally ingested, problems such as respiratory difficulties or allergic reactions could result.



Be careful not to get any of the glue which has been applied to the cloth into your eyes or onto your skin.

If this is not observed, problems such as inflammation or allergic reactions could result.



Do not immerse the bonding machine in liquid.

In addition, do not place objects on top of the bonding machine. If the contents of cups or other objects containing liquids spill onto the bonding machine, fire, electric shocks or problems with operation could result. If any liquid gets into the bonding machine (including the machine head and control box), immediately turn off the power switch, disconnect the power plug.



CAUTION



Attach all safety devices before using the bonding machine.



If the bonding machine is used without these devices attached, burns or injury may result.



If using a table which has casters, the casters should be secured in such a way so that they cannot move.



Do not touch the nozzle while using or after using the bonding machine. The nozzle becomes hot during use, and burns may result.



If there is a chance that you may touch the nozzle, be sure to wear protective gloves (*1).



Do not open the melter cover except when replacing the glue cartridge.



The equipment inside the melter cover, the melter, the glue cartridge and the cartridge valve become hot during use and may cause burns if touched.



Do not touch any of the moving parts or press any objects against the machine while using the bonding machine, as this may result in injury or damage to the bonding machine.



If an error occurs in machine operation, or if abnormal noises or smells are noticed, immediately turn off the power switch.

(*1) Use protective gloves which can withstand temperatures of 200°C and higher.

6.1 Selecting program No.

Refer to "3.2" to select a program number, and load the program which is needed for gluing.

6.2 Gluing

Display the home screen.

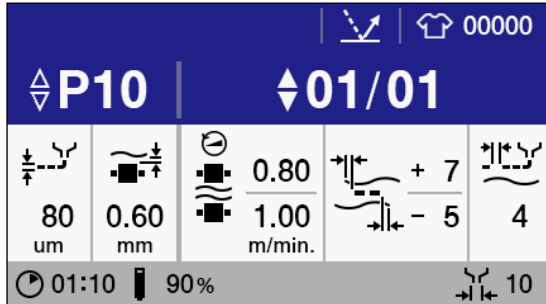

1. If necessary, follow the procedures in "3.2" and "3.2.4" to select the program and steps to use.
2. Press the NOZZLE switch.
The nozzle will move down to its lowest position.
3. After depressing the treadle, return it to its neutral position.
The cloth plate will drop and air will start blowing around the upper cloth plate.
4. Set the lower cloth under the upper cloth plate. At this time, align the leading end of the lower cloth in the cloth feed direction with the positioning LED marker.
5. After depressing the treadle, return it to its neutral position.
The lower edge control roller will rotate and the horizontal position for the lower cloth will be determined automatically.
* Hold the cloth to that it does not move forward or back. If the cloth moves forward or back by mistake, align the leading end of the lower cloth with the positioning LED marker once again.
6. After depressing the treadle, return it to its neutral position.
The cloth plate will lift up and the lower cloth presser will drop and secure the lower cloth.
* Be careful to avoid getting your hand caught.
7. Place the upper cloth on top of the upper cloth plate, and while looking in the mirror, align the leading end of the upper cloth with the leading end of the lower cloth.
8. After depressing the treadle, return it to its neutral position.
The upper edge control roller will drop and rotate, and the horizontal position for the cloth will be determined automatically.
* Be careful to avoid getting your hand caught.
* Hold the cloth to that it does not move forward or back. If the cloth moves forward or back by mistake, align the leading end of the upper cloth with the leading end of the lower cloth once again.
9. After depressing the treadle, return it to its neutral position.
The upper roller will move down.
10. Check if the indicator of the GLUE ON/OFF switch is illuminated.
If it is illuminated, glue discharge is enabled, and if it is turned off, glue discharge is disabled.
The indicator will illuminate or switch off each time the GLUE ON/OFF switch is pressed.
11. When the treadle is depressed, gluing will start.
The lower cloth presser will lift up.
 - If end detection is enabled
When the end of the cloth is detected, glue discharge automatically stops, but the cloth continues feeding.
Once all of the cloth had been fed through, return the treadle to the neutral position.
 - If end detection is disabled
Glue will be discharged while the treadle is being depressed.
If you would like to stop gluing, return the treadle to the neutral position.
12. Depress the treadle backward and take out the cloth.
The upper roller will lift up and the upper edge control roller and lower edge control roller will retract.

- * If the treadle is depressed at any time up to and including step 10, you can return to the status immediately before that step.
For example, if you depress the treadle after carrying out the procedure in step 3, the cloth plate will lift.
- * If a program which has multiple steps registered is selected, then while the treadle is being depressed in step 12, the steps can be switched by pressing the knee switch.

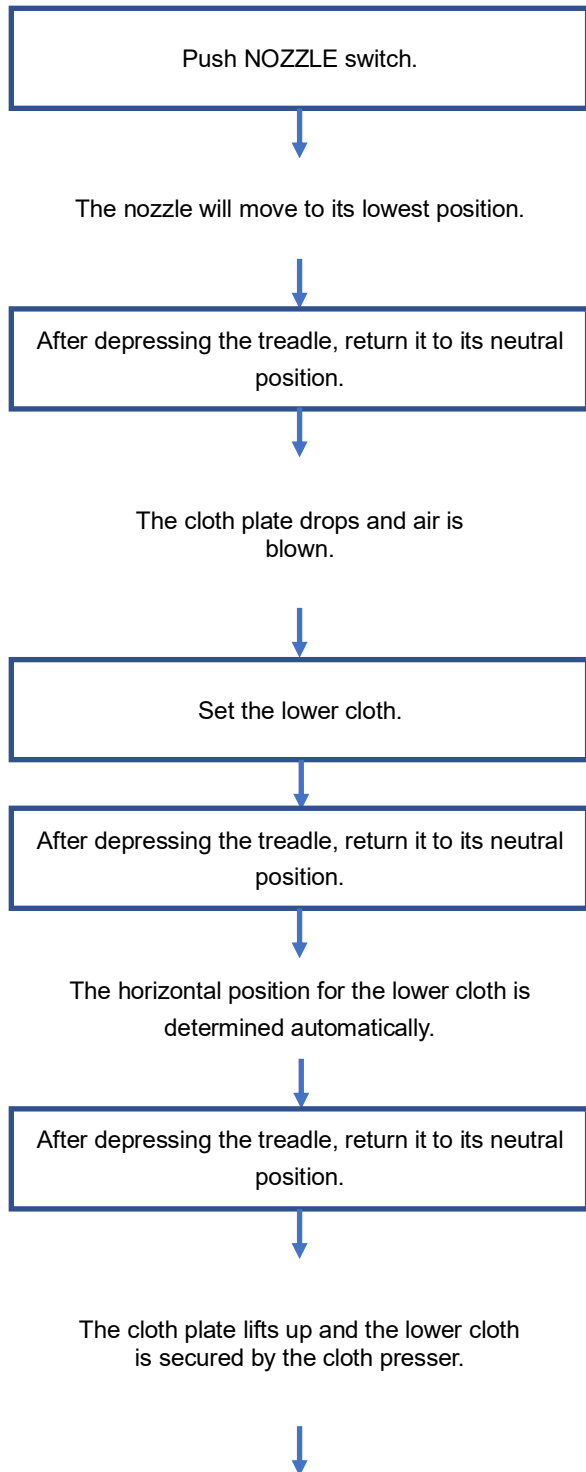

6 GLUING

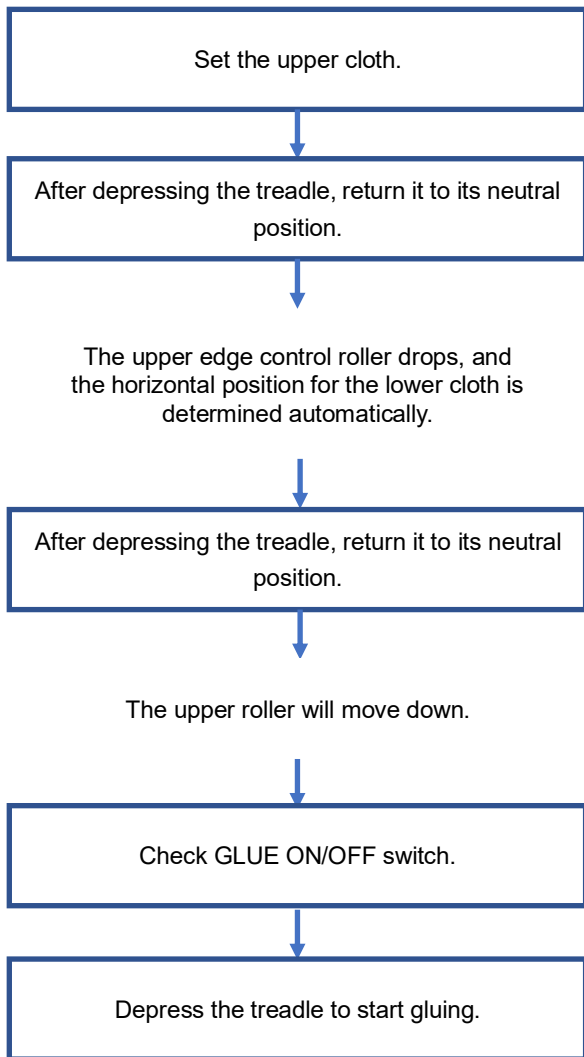

Switching the step while gluing

If you would like to change the feed speed or the glue-free width while gluing is in progress, this can be done by switching steps.

- * The glue thickness and nozzle clearance cannot be changed by switching steps, and so if you would like to change the glue thickness or the nozzle clearance, it will be necessary to switch the entire program.
- * It is possible to switch steps while gluing is in progress, but it is necessary to stop gluing first before programs can be switched.

If the X-over sensor is not operating, change the program if you would like to increase the glue thickness.

1. Set the following memory switch to "1" or "2".

Refer to "3.5" for details on the memory switch setting method.

Memory switch No.	Setting	Setting range
231	Program/Step changing method	1: Change step with knee switch 2: Change step with knee switch and change program with Op hand switch 3: Change program with knee switch

2. Display the home screen and select the step.

From 1 to 8 steps can be set for a single program.

If you would like to change the gluing conditions while gluing is in progress, you can change the settings for the parameters where the conditions are to be changed. Refer to "3.2.4 Step setting method" for details on adding, deleting and selecting steps.

3. While the program which contains the set step is being displayed, start gluing, and then when you reach the point where you would like to switch the step, press the knee switch to switch to the next step.

P01 01/03 (When up to 3 steps have been set for program 1)

(Example: STEP01 → Knee switch → STEP02 → Knee switch → STEP03)

Switching the program while gluing

If X-over detection is not used when gluing thin cloth, or if you would like to change the nozzle clearance or the glue thickness while gluing is in progress, you can change the program being used.

- * The glue thickness and nozzle clearance cannot be changed by switching steps, and so if you would like to change the glue thickness or the nozzle clearance, it will be necessary to switch the entire program.
- * It is possible to switch steps while gluing is in progress, but it is necessary to stop gluing first before programs can be switched.

4. Set the following memory switch to "2" or "3".

Refer to "3.5" for details on the memory switch setting method.

Memory switch No.	Setting	Setting range
231	Program/Step changing method	1: Change step with knee switch 2: Change step with knee switch and change program with Op hand switch 3: Change program with knee switch

5. Display the home screen, and enter the parameters for the programs which will be used consecutively before and after switching.

The program will switch to the program with the next number, so enter the parameters for the program with the number that will come after the program which was being displayed before switching.

Refer to "3.2.1 Parameter list" through to "3.2.3 Nozzle clearance setting method" for details on entering parameters.

6 GLUING

6. While the program before switching is being displayed, start gluing, and then when you reach the point where you would like to switch the program, stop gluing, and then press the Op hand switch or the knee switch to switch to the next-numbered program.

(Example: P10 → Op hand switch → P11 → Op hand switch → P12 → Op hand switch → P13 → Op hand switch → P14 ...)

You can easily return to a selected program number using the settings for the following memory switches.

Refer to "3.5" for details on the memory switch setting method.

Memory switch No.	Setting	Setting range
221	Program number selected when F1 is pressed at the home screen	OFF, 1 - 30
222	Program number selected when F2 is pressed at the home screen	OFF, 1 - 30
223	Program number selected when F3 is pressed at the home screen	OFF, 1 - 30
224	Program number selected when F4 is pressed at the home screen	OFF, 1 - 30
225	Program number selected when F5 is pressed at the home screen	OFF, 1 - 30
226	Program number selected when F6 is pressed at the home screen	OFF, 1 - 30

(Example: Set memory switch No. 221 to "10")

Press any one of the keys from the F1 key to the F6 key to return to the selected program.

(Example: P10 → Op hand switch → P11 → Op hand switch → P12 → Op hand switch → P13 → F1 → P10)

Fine adjustment for upper roller feed speed

If either the upper cloth or lower cloth slips out of alignment in the feed direction while gluing is in progress, you can make fine adjustments to the upper roller feed speed to correct the mis-alignment between the upper cloth and the lower cloth.

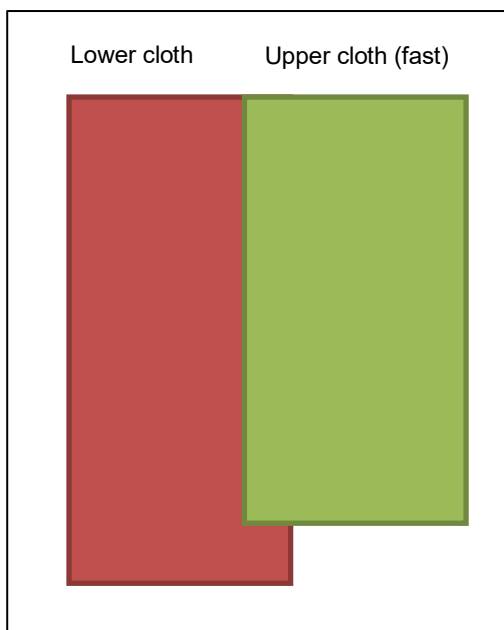

< If upper cloth moves faster >

Move the feed speed adjustment switch (1) to the down position.

The upper roller feed speed will become slower by the ratio which has been set in memory switch No. 255.

The upper roller feed speed will become slower even if gluing operation is still in progress.

Refer to "3.5" for details on the memory switch setting method.

Memory switch No.	Setting	Setting range
255	Upper roller speed deceleration rate when feed speed adjustment switch is moved down	-10.0 - 0.0[%]

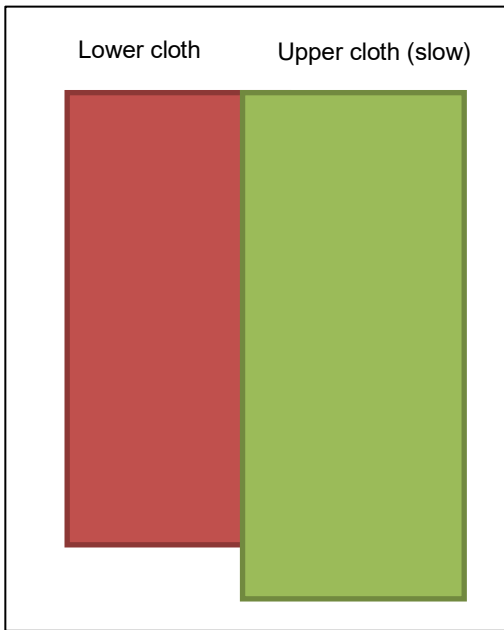

< If upper cloth moves more slowly >

Move the feed speed adjustment switch (1) to the up position.

The upper roller feed speed will become faster by the ratio which has been set in memory switch No. 256.

The upper roller feed speed will become faster even if gluing operation is still in progress.

Refer to "3.5" for details on the memory switch setting method.

Memory switch No.	Setting	Setting range
256	Upper roller speed acceleration rate when feed speed adjustment switch is moved up	0.0 - 10.0[%]

Once the mis-alignment between the the upper cloth and the lower cloth has been eliminated, return the feed speed adjustment switch to the neutral position.

If you try to start gluing while the feed speed adjustment switch is at either the up or down position, an error will occur. Return it to the neutral position before starting gluing.

7 GLUING STOP METHOD

7.1 Stopping the machine

When stopping gluing, attach the cap to the nozzle and discharge the air from inside the nozzle in order to prevent the glue inside the nozzle from solidifying.

1. Display the home screen.
2. Press the  key to display shutdown procedure screen.

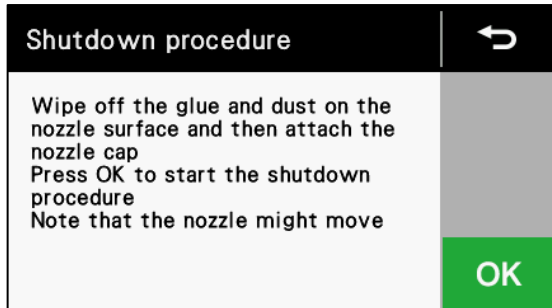

3. If the nozzle is in the gluing position, press the NOZZLE switch to raise the nozzle to the up position.
4. Use a cloth or similar to wipe off any glue and foreign particles from the surface of the nozzle (in particular the discharge hole side (1)).

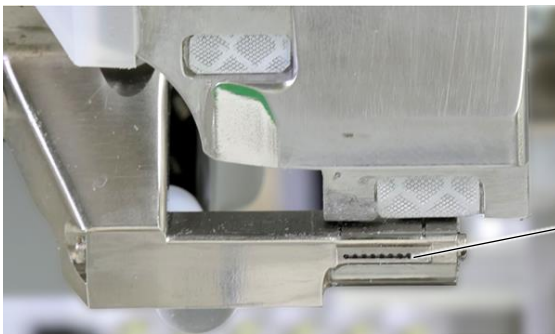

5. Use a cloth or similar to wipe off any glue and foreign particles from the plastic surfaces of the nozzle cap (2).
Note: Be sure to wipe off any residual glue, otherwise it might cause the nozzle to become blocked.



7 GLUING STOP METHOD

- Align the projection (4) of the nozzle cap with the hollow in the upper cloth plate, and then attach the nozzle cap, and turn the knob (3) to tighten it.



- Touch **OK**. Note that if the nozzle is in the up position, it will move at this time.
- Wait a few seconds for the panel display to change, and then turn off the power switch.

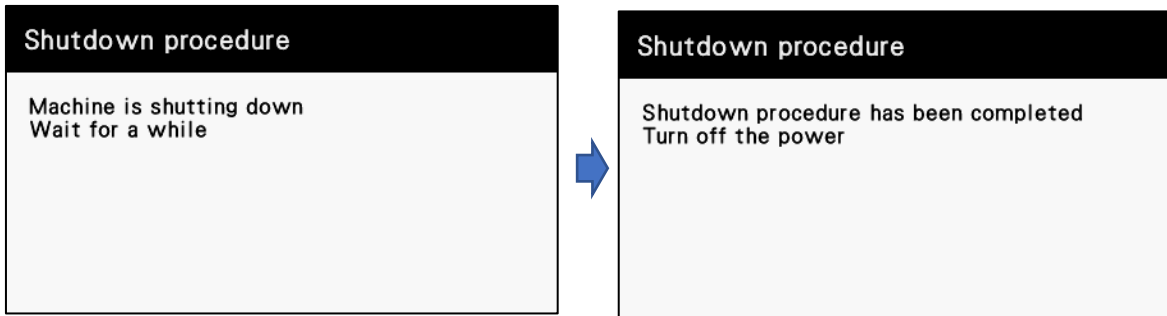

If the following error is displayed, it is possible that the plastic surface of the nozzle cap is not properly covering the nozzle discharge holes.

Remove the nozzle cap and reattach it, and then touch .

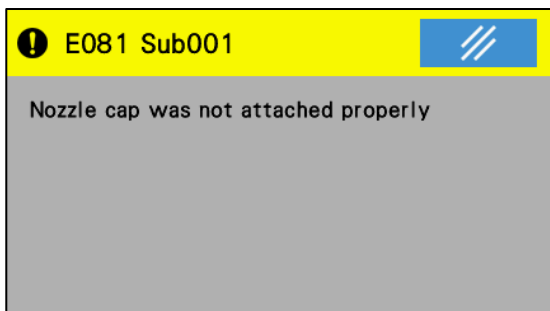

8 OTHER FUNCTIONS

WARNING



Wear protective goggles when operating the bonding machine to avoid getting any glue into your eyes.



Furthermore, avoid getting the glue onto your skin. If this is not observed, problems such as burns, inflammation or allergic reactions could result.



Avoid drinking, eating and smoking while using the glue.

If the glue is accidentally ingested, problems such as respiratory difficulties or allergic reactions could result.



Be careful not to get any of the glue which has been applied to the cloth into your eyes or onto your skin.

If this is not observed, problems such as inflammation or allergic reactions could result.



Do not immerse the bonding machine in liquid.



In addition, do not place objects on top of the bonding machine. If the contents of cups or other objects containing liquids spill onto the bonding machine, fire, electric shocks or problems with operation could result. If any liquid gets into the bonding machine (including the machine head and control box), immediately turn off the power switch, disconnect the power plug.



CAUTION



Attach all safety devices before using the bonding machine.



If the bonding machine is used without these devices attached, burns or injury may result.



If using a table which has casters, the casters should be secured in such a way so that they cannot move.



Do not touch the nozzle while using or after using the bonding machine. The nozzle becomes hot during use, and burns may result.



If there is a chance that you may touch the nozzle, be sure to wear protective gloves (*1).



Do not open the melter cover except when replacing the glue cartridge.



The equipment inside the melter cover, the melter, the glue cartridge and the cartridge valve become hot during use and may cause burns if touched.



Do not touch any of the moving parts or press any objects against the machine while using the bonding machine, as this may result in injury or damage to the bonding machine.



If an error occurs in machine operation, or if abnormal noises or smells are noticed, immediately turn off the power switch.

(*1) Use protective gloves which can withstand temperatures of 200°C and higher.

8.1 X-over bonding

When the X-over detection function is enabled, the nozzle clearance can be changed automatically at places where the thickness of the lower cloth changes greatly.

- If the X-over detection function is enabled when using thin lower cloth, changes in the thickness of the lower cloth may not be detected, and the nozzle clearance may not change.
In such cases, disable the X-over detection function, and follow the procedure given in "Switching the program while gluing".
Refer to "Switching the program while gluing" in "6.2 Gluing" for details on the method of use.
 - If the setting for the nozzle clearance in the selected program is very narrow, the nozzle clearance may change at places where the thickness of the lower cloth does not change.
In such cases, make the setting for memory switch No. 422 smaller.
 - * Refer to "3.5" for details on the memory switch setting method.
1. Set memory switch No. 421 to "ON".
 2. If you would like to change the amount by which the nozzle clearance changes, change the setting for memory switch No. 424.
 - * When "AUTO" is set, the amount of change in the nozzle clearance will be the same as the setting value for the nozzle clearance in the currently-selected program.
 - * At the time of shipment from the factory, it is set to "AUTO".

8.2 End detection

This function uses a sensor to detect the end of the lower cloth while gluing is being carried out, in order to stop the discharge of glue automatically.

[End glue-free length setting method]

Change the setting value for memory switch No.531.

Adjust to a suitable value based on "21 - Glue-free length".

Refer to "3.5" for details on the memory switch setting method.

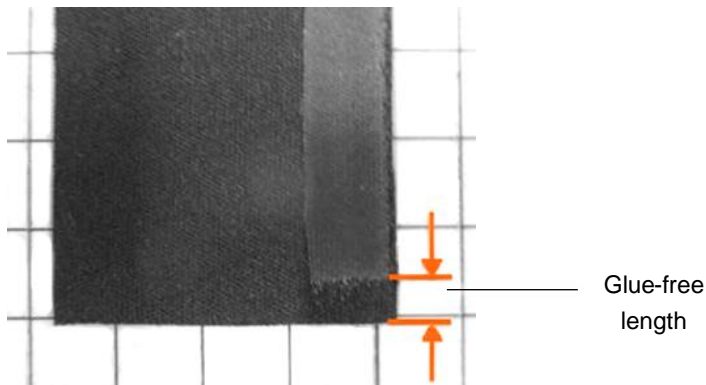



NOTE:

The initial setting is for glue to be applied for the duration that the edge control roller is pressing the cloth.

If the glue-free length is changed to a smaller setting, the cloth will be separated from the edge control roller, and so for some types of cloth, the cloth may slip sideways and the glue will be applied outside the edges of the cloth.

[End detection disabling method]

If you do not want the glue to be stopped automatically when the end of the lower cloth is reached, you can touch the end detection icon  on the operation panel to disable end detection.

When end detection is disabled, the icon will change to .

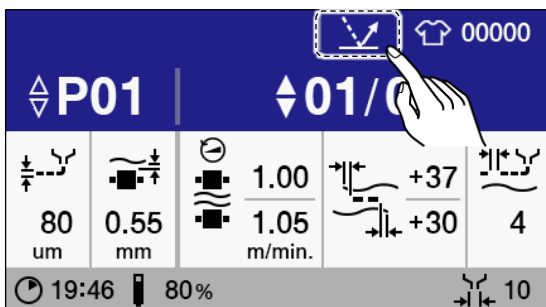

9 REPLACING GLUE CARTRIDGE

9.1 About glue level indicator

The amount of glue remaining is displayed as a percentage next to the  icon at the bottom of the home screen.

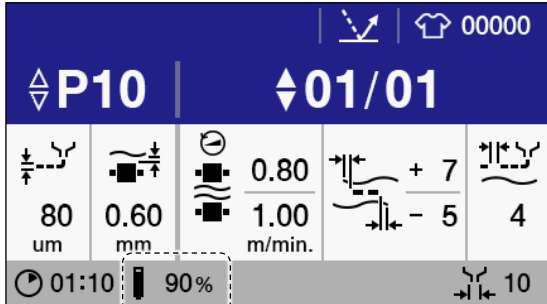

Amount of glue remaining

When the amount of glue remaining reaches 3%, error E901 will be displayed. When the error is displayed, touch  to clear the error. After this, error E901 will be displayed each time the treadle is depressed.

When the amount of glue remaining reaches 0%, error E900 will be displayed. Even if you touch  to clear the error, the bonding machine will not continue on to the next process.

Replace the glue cartridge as soon as possible after error E901 starts to appear.

9.2 Glue cartridge replacing method

⚠ WARNING



Wear protective gear such as protective goggles and protective gloves ^(*) when replacing the glue cartridge in order to avoid exposure to your skin. The equipment inside the melter cover, the melter, the glue cartridge and the cartridge valve become hot during use and could cause burns if touched.



In addition, set the cartridge valve so that it is facing upward before removing it, and be careful not to get any of the glue into your eyes or onto your skin. If the valve is facing downward, glue may flow out and problems such as burns, inflammation or allergic reactions could result.



Avoid drinking, eating and smoking while using the glue.

If the glue is accidentally ingested, problems such as respiratory difficulties or allergic reactions could result.



Keep the glue out of the reach of children.

⚠ CAUTION



Use only genuine Brother glue cartridges. Brother will not be held responsible for any accidents or problems resulting from the use of non-genuine parts.



Wash your hands thoroughly after using the glue.

(*1) Use protective gloves which can withstand temperatures of 200°C and higher.

1. Press the  key to display the setting menu.
2. Touch "Cartridge exchange" to display the cartridge exchange screen.

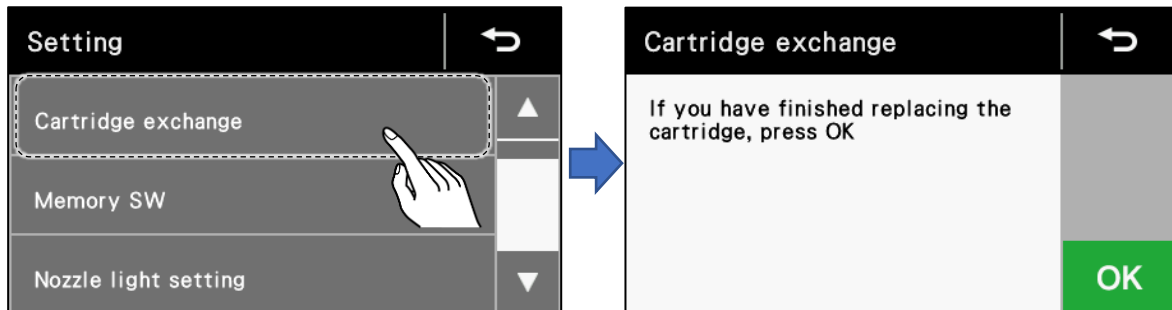

9 REPLACING GLUE CARTRIDGE

3. Turn the melter cover (1) in the direction of the arrow to remove it.

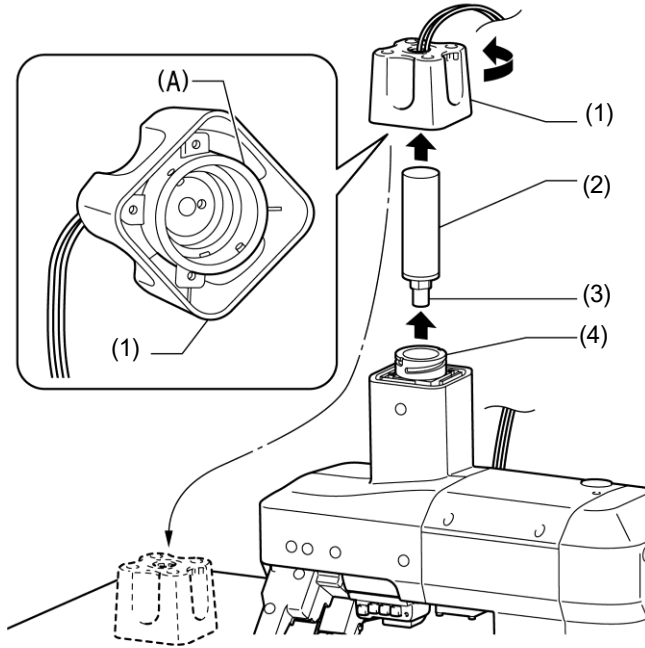

NOTE:

- The metal part (A) inside the removed melter cover (1), the glue cartridge (2), the cartridge valve (3) and the melter (4) will all be hot, so be careful not to touch them directly against your skin. If they touch your skin, burns may result.
- Place the removed melter cover (1) onto the table. Do not place the melter cover (5) onto the bonding machine, as it may fall off.

4. Take off the glue cartridge (2).
5. With the cartridge valve (3) facing upward, use a wrench to remove the cartridge valve (3) from the glue cartridge (2).

NOTE:

- Set the cartridge valve (3) so that it is facing upward before removing it, and be careful not to get any of the glue into your eyes or onto your skin. If the valve is facing downward, glue may flow out and problems such as burns, inflammation or allergic reactions could result.
- Follow all applicable regulations when disposing of used glue cartridges.

6. Use the punch (5) on the table to make a hole in the new glue cartridge (6).

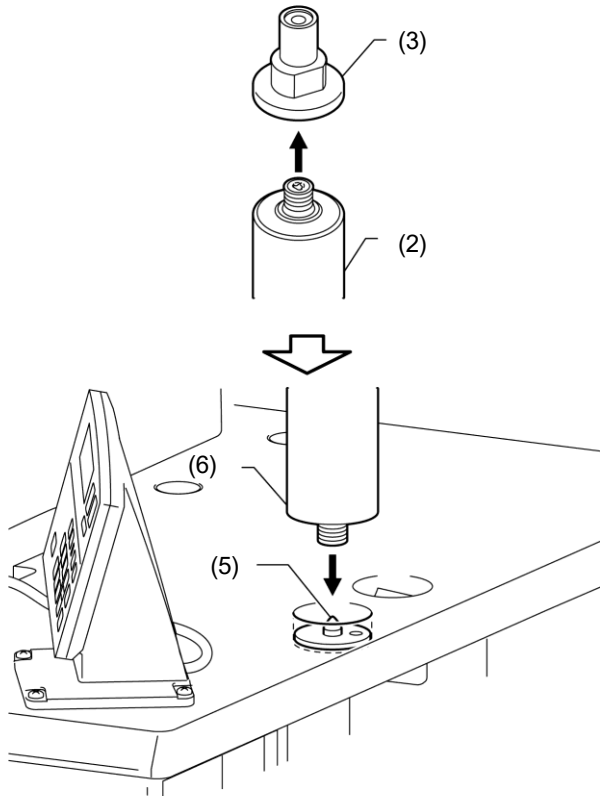

NOTE:

- Make sure that you only use the punch (5) to make the hole.

7. Install the cartridge valve (3) to the glue cartridge (6).

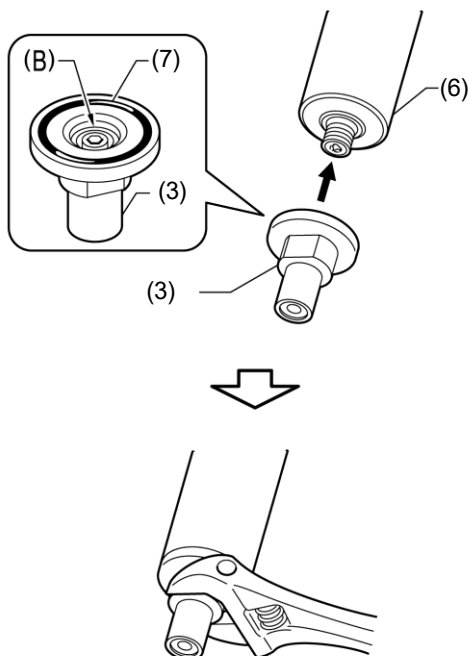

NOTE:

- Check that the O-ring (7) of the cartridge valve (3) is free from foreign particles and damage.
- If the O-ring (7) is damaged, replace the O-ring (7).
- Check that there is no dirt or glue on the threaded part (B) of the cartridge valve (3).
- After screwing in the cartridge valve (3) by hand, use a wrench to tighten the cartridge valve (3) so that there is no gap between it and the glue cartridge (6).

9 REPLACING GLUE CARTRIDGE

8. Install the glue cartridge (6) to the melter (4) of the machine head.

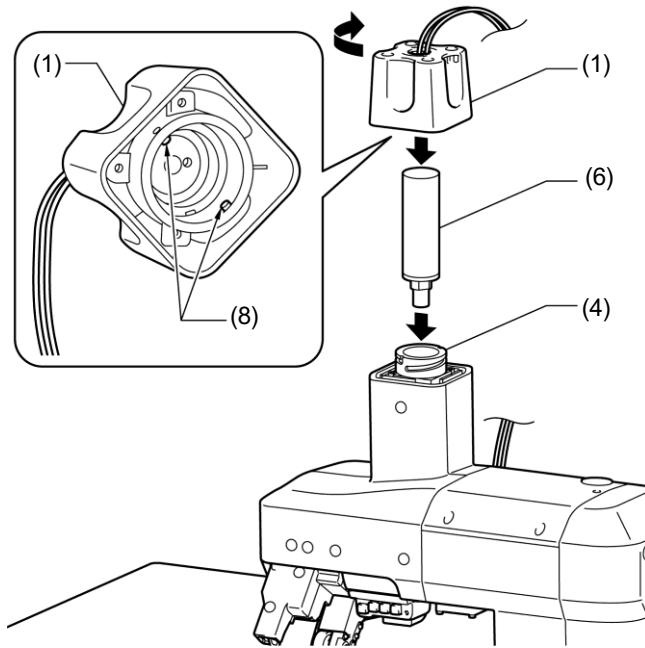

9. Fit the bosses (8) inside the melter cover (1) into the grooves in the melter (4), and then turn the melter cover (1) in the direction of the arrow to install it.
10. Use a cloth or similar to wipe off any glue which may be adhering to the punch (5).

NOTE:

- Be careful not to let any of the glue get onto your skin.
11. Once the glue cartridge has been replaced, touch **OK**.
 12. The panel display will switch as showed below. Wait for a further 15 minutes or so.

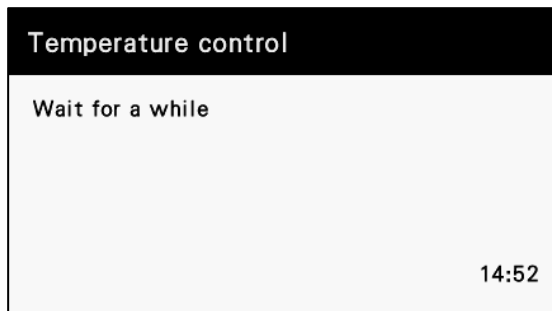

13. The following screen appears.

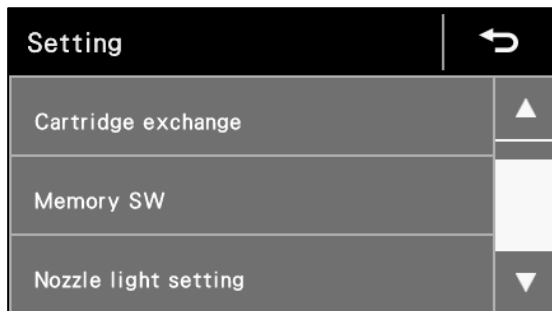

14. Discharge the glue from the replacement cartridge for the specified length of time for the cartridge.

Refer to "4.2.2 Automatic discharge mode" for details on the specified time.

If this step is not carried out, air bubbles may become mixed in with the discharged glue, and this will weaken the adhesion strength.

10 CLEANING

10.1 Cleaning the upper roller, lower roller and roller under nozzle

WARNING



When carrying out this operation, be sure to wear protective goggles and protective gloves^(*1). The nozzle becomes hot during use, and burns could result.



Avoid drinking, eating and smoking while carrying out this operation.

If the glue is accidentally ingested, problems such as respiratory difficulties or allergic reactions could result.



Furthermore, if the glue comes into contact with your eyes or skin, problems such as burns, inflammation or allergic reactions could result.



CAUTION





If the power switch and air need to be left on when carrying out some task, be extremely careful to observe all safety precautions.

If you depress the treadle or the switches by mistake, it will cause the machine to operate, and injury may result.

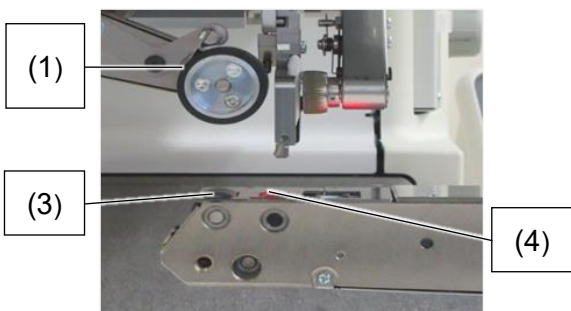
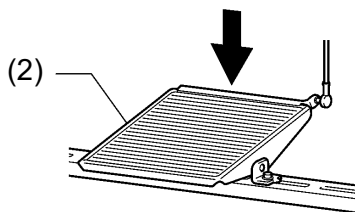
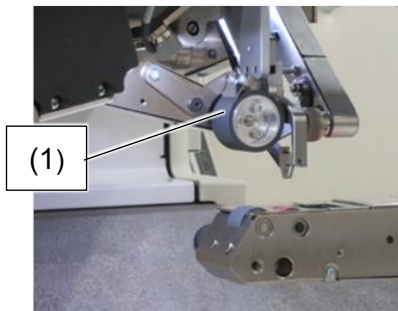
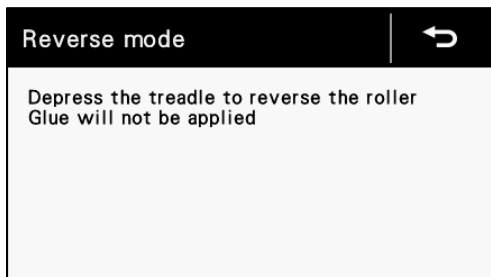
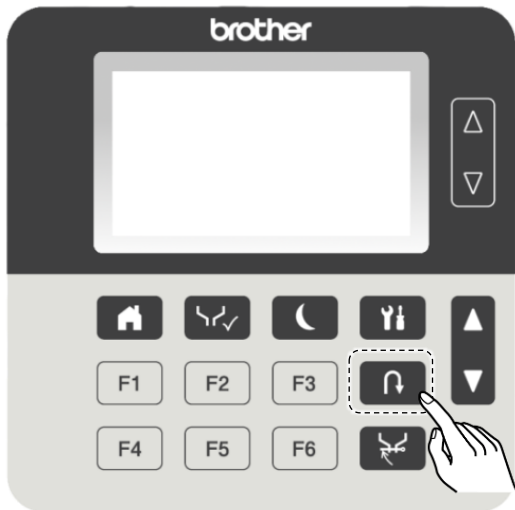
(*1) Use protective gloves which can withstand temperatures of 200°C and higher.



1. Display the home screen.
2. Press the  key to raise the upper roller (1).
 - * The display will switch to reverse mode.

3. Depress the treadle (2) to turn the upper roller (1), lower roller (3) and nozzle lower roller (4) to positions where the dirtiness can be checked.
 - * The direction of rotation will be the reverse of normal operation.
 - * No glue will come out after the  key has been pressed, even when the treadle (2) is depressed.

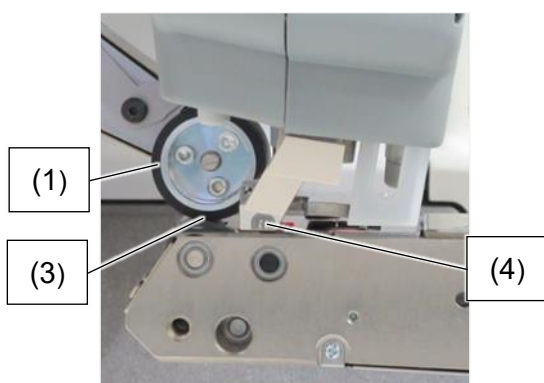

4. Use a soft cloth to wipe the upper roller (1), lower roller (3) and nozzle lower roller (4) clean.

NOTE:

Do not use hard objects such as tweezers to clean the upper roller (1), lower roller (3) and nozzle lower roller (4), as such objects may cause damage.

If dirt cannot be removed, wipe the roller with a cloth which is lightly soaked in ethanol to clean it.

5. While turning the upper roller (1), lower roller (3) and nozzle lower roller (4), wipe them until no dirtiness remains.
6. Press the  key to lower the upper roller (1) and to switch machine back to gluing mode.

* The display will return to normal status from reverse mode.

10.2 Cleaning the nozzle discharge holes

WARNING



When carrying out this operation, be sure to wear protective goggles and protective gloves^(*1). The nozzle becomes hot during use, and burns could result.



Furthermore, if the glue comes into contact with your eyes or skin, problems such as burns, inflammation or allergic reactions could result.



Avoid drinking, eating and smoking while carrying out this operation.

If the glue is accidentally ingested, problems such as respiratory difficulties or allergic reactions could result.

CAUTION



If the power switch and air need to be left on when carrying out some task, be extremely careful to observe all safety precautions.

If you depress the treadle or the switches by mistake, it will cause the machine to operate, and injury may result.



Wash your hands thoroughly after carrying out this operation.

(*1) Use protective gloves which can withstand temperatures of 200°C and higher.

If problems such as uneven application of the glue occur because the nozzle discharge holes are blocked with glue, carry out the following procedure to clean the nozzle discharge holes.

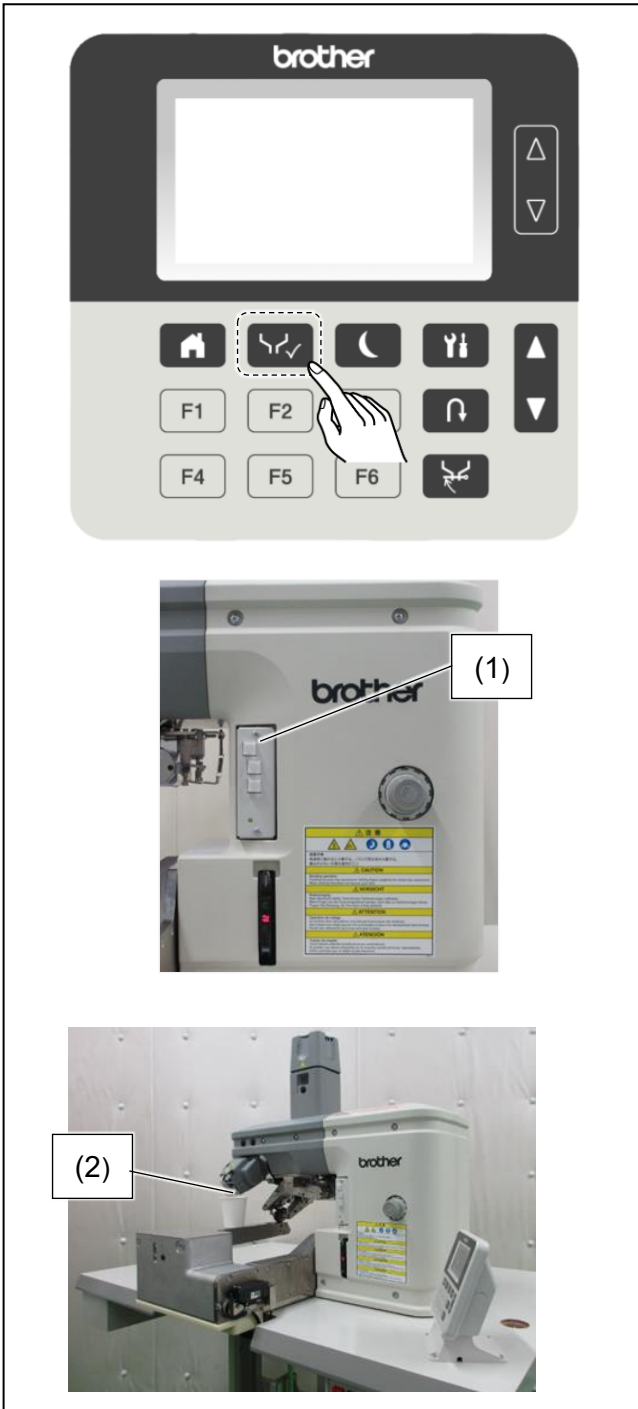

1. Press the  key to switch to test mode.
* The display will switch to test mode.

2. Push the NOZZLE switch (1) to move the nozzle (2) to its highest position.
Place something such as a cup underneath the nozzle (2) to prevent any glue from dripping onto the table.

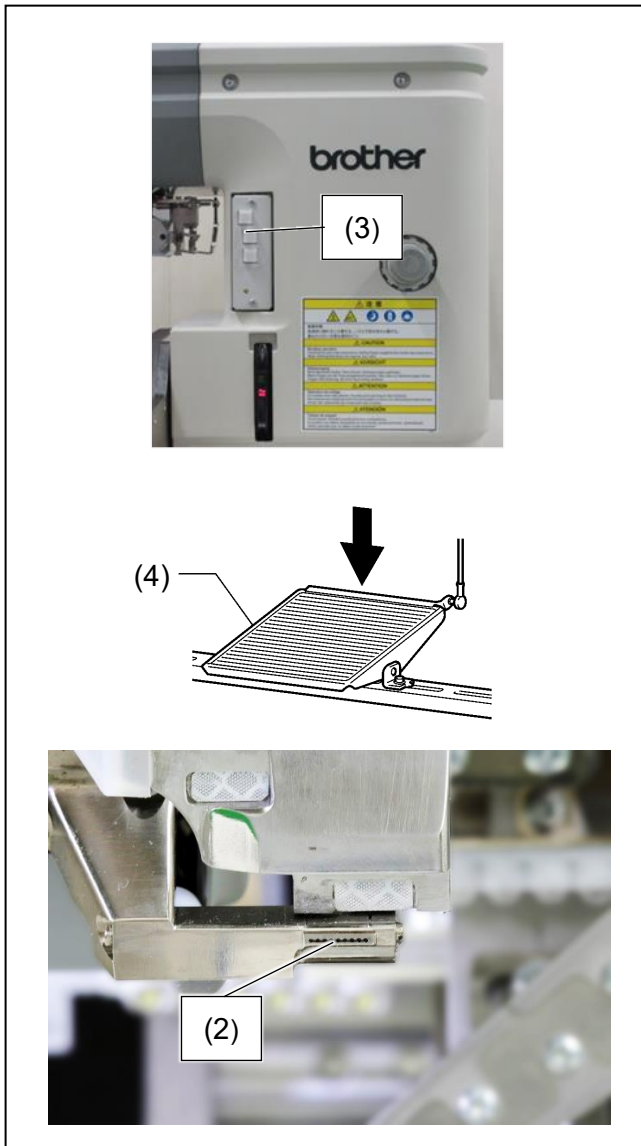

3. While pressing the GLUE ON/OFF switch (3), depress the treadle (4) to the position where glue is discharged from the nozzle (2).

* Once glue starts to be discharged, it will continue to be discharged even after you release the GLUE ON/OFF switch (3).

* Check the positions of any discharge holes in the nozzle (2) which are blocked.

4. Use a cloth or similar to wipe off any glue which is adhering to the nozzle (2).

5. Turn off the power switch.

! CAUTION	
	If you carry out the next operation while the power switch is still turned on, the nozzle (2) may move if the NOZZLE switch is pressed by mistake, and injury may result.

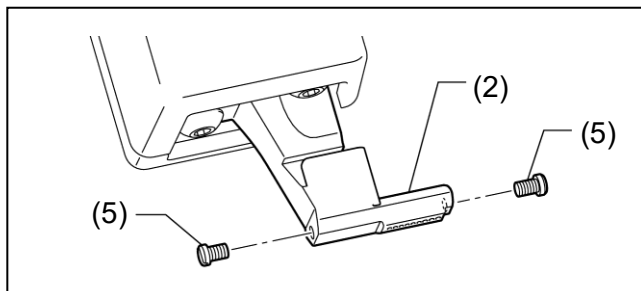

6. Remove the screws (5) at the side of the nozzle (2).

* Remove the two screws.

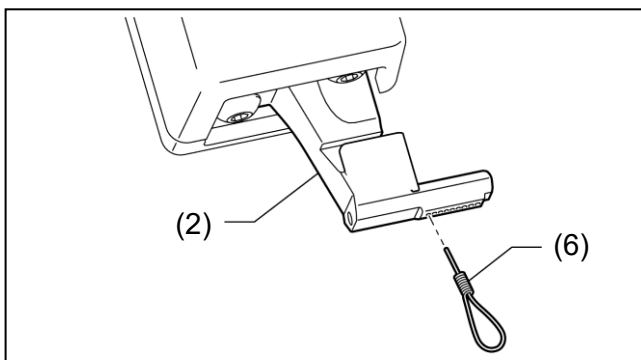

7. Insert the nozzle cleaning pin 0.48 (6) into the discharge holes of the nozzle (2) to remove any blockages from the discharge holes in the nozzle (2).

NOTE:

In order to prevent the glue from solidifying, clean the nozzle within 10 minutes after turning off the power, and then turn the power switch back on and discharge the glue.

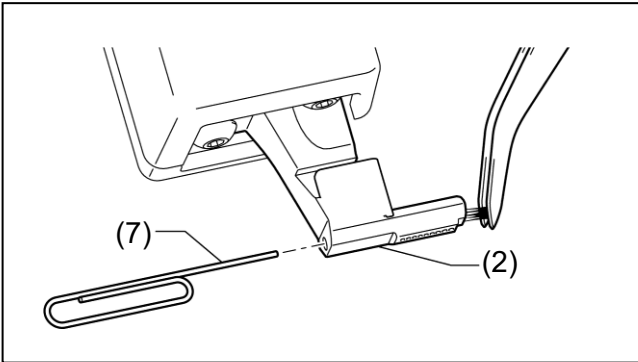

8. Insert the nozzle cleaning pin 1.5 (7) into the screw hole in the nozzle (2) to remove any blockages from the glue path in the nozzle (2).

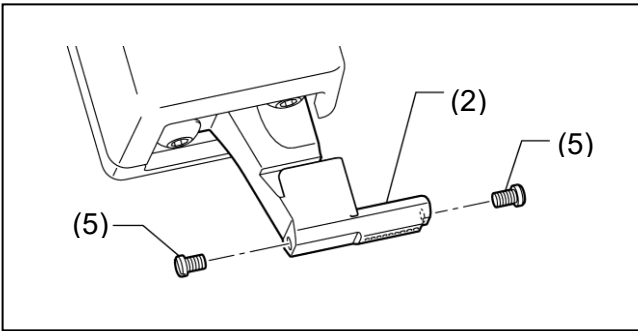

9. Install the screws (5) to the nozzle (2).
 - * Install the two screws.

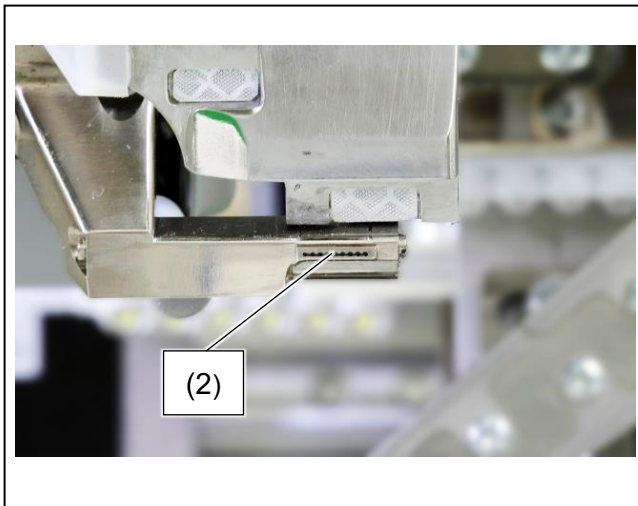

10. Discharge the glue and check that glue come out from all of the discharge holes in the nozzle (2). (Refer to "4.2" for details on the discharging method.)
 - * If glue is not coming out from all of the discharge holes in the nozzle (2), clean the discharge holes of the nozzle (2) once more.

10.3 Cleaning the cloth plate

WARNING



When carrying out this operation, be sure to wear protective goggles and protective gloves^(*1). The nozzle becomes hot during use, and burns could result.



Avoid drinking, eating and smoking while carrying out this operation.



Furthermore, if the glue comes into contact with your eyes or skin, problems such as burns, inflammation or allergic reactions could result.

If the glue is accidentally ingested, problems such as respiratory difficulties or allergic reactions could result.



CAUTION





If the power switch and air need to be left on when carrying out some task, be extremely careful to observe all safety precautions.

If you depress the treadle or the switches by mistake, it will cause the machine to operate, and injury may result.

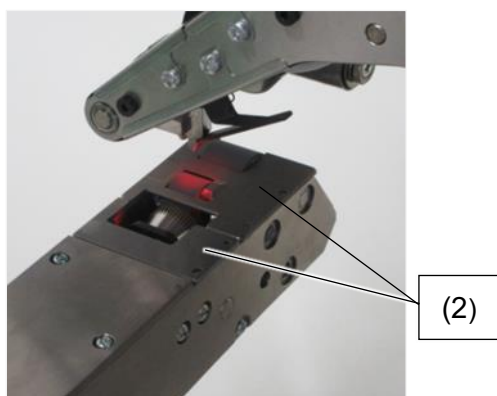
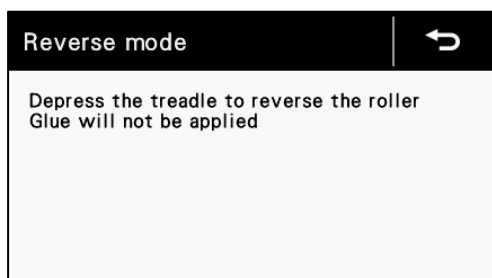
(*1) Use protective gloves which can withstand temperatures of 200°C and higher.



1. Press the  key to display the home screen.
2. Press the NOZZLE switch to raise the nozzle.
3. Press the  key to raise the upper roller (1) and to switch the machine to reverse rotation mode.
4. Use a cloth to wipe off any glue, dirt or other foreign particles which are adhering to the cloth plate (2).
 - The cloth plate can be removed easily by lifting it up. Use a cloth to wipe off any glue, dirt or other foreign particles which are adhering to the underside of the cloth plate. After removing the cloth plate to clean it, re-install it securely in its original position. Align the pin with the hole in the cloth plate when re-installing.

10.4 Cleaning the edge control roller

WARNING



When carrying out this operation, be sure to wear protective goggles and protective gloves^(*1). The nozzle becomes hot during use, and burns could result.



Avoid drinking, eating and smoking while carrying out this operation.



Furthermore, if the glue comes into contact with your eyes or skin, problems such as burns, inflammation or allergic reactions could result.

If the glue is accidentally ingested, problems such as respiratory difficulties or allergic reactions could result.



CAUTION





If the power switch and air need to be left on when carrying out some task, be extremely careful to observe all safety precautions. If you depress the treadle or the switches by mistake, it will cause the machine to operate, and injury may result.

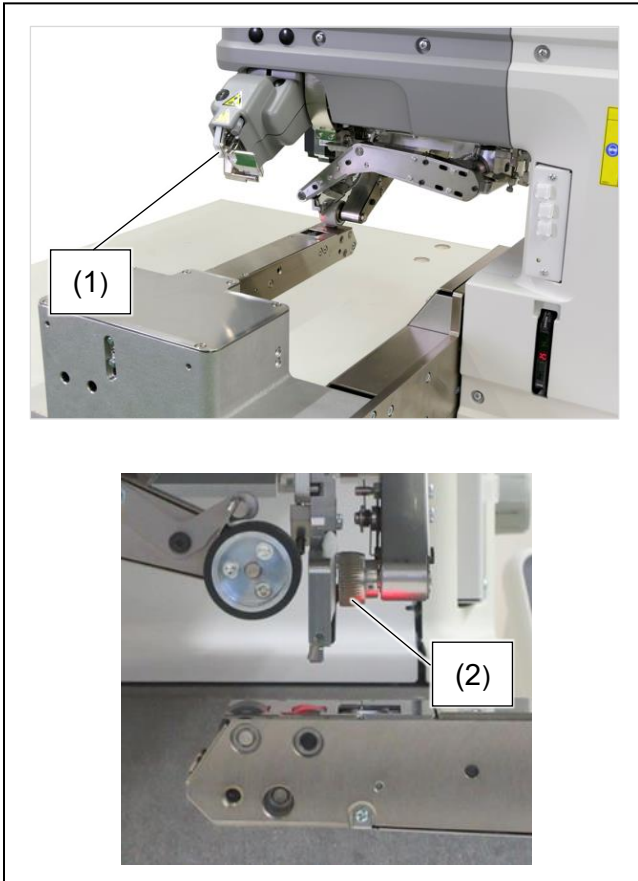

Wash your hands thoroughly after carrying out this operation.

(*1) Use protective gloves which can withstand temperatures of 200°C and higher.

[Cleaning the upper edge control roller]

1. Press the  key to display the home screen.
2. Press the NOZZLE switch to raise the nozzle (1).
3. Use a soft cloth to wipe off any glue, dirt or other foreign particles which are adhering to the upper edge control roller (2).

NOTE:

Do not use hard objects such as tweezers to clean the upper edge control roller (2), as such objects may cause damage. If dirt cannot be removed, wipe the roller with a cloth which is lightly soaked in ethanol to clean it.

[Cleaning the lower edge control roller]

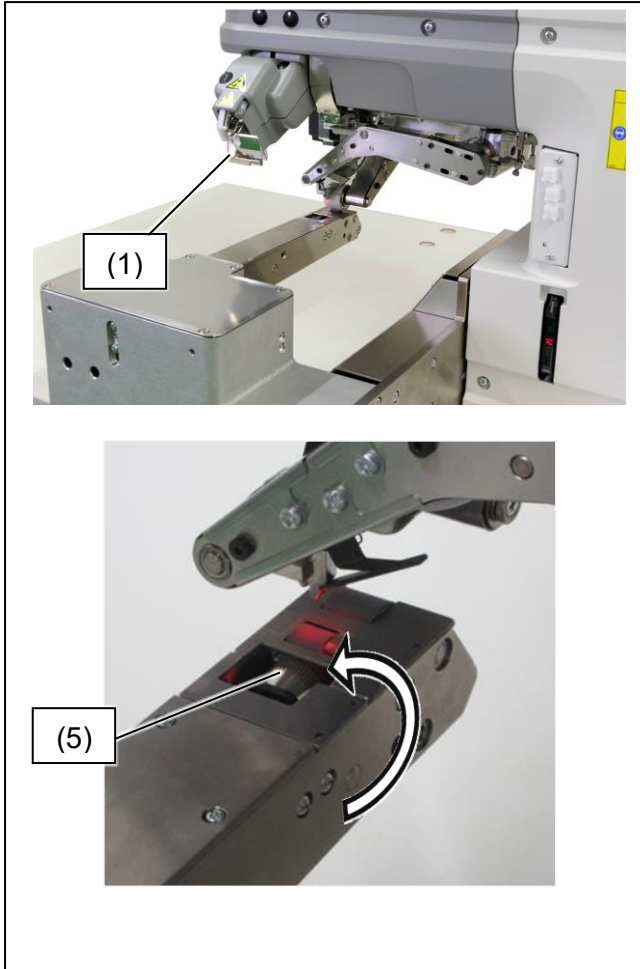

1. Press the  key to display the home screen.
2. Press the NOZZLE switch to raise the nozzle (1).
3. Remove the cloth plates (3) and (4).
4. Use a soft cloth to wipe off any glue, dirt or other foreign particles which are adhering to the lower edge control roller (5).
5. After removing the cloth plate to clean it, re-install it securely in its original position.

NOTE:

Do not use hard objects such as tweezers to clean the lower edge control roller (5), as such objects may cause damage.

If dirt cannot be removed, wipe the roller with a cloth which is lightly soaked in ethanol to clean it.

10.5 Cleaning the reflector

WARNING



When carrying out this operation, be sure to wear protective goggles and protective gloves^(*1). The nozzle becomes hot during use, and burns could result.



Furthermore, if the glue comes into contact with your eyes or skin, problems such as burns, inflammation or allergic reactions could result.



Avoid drinking, eating and smoking while carrying out this operation.

If the glue is accidentally ingested, problems such as respiratory difficulties or allergic reactions could result.

CAUTION



If the power switch and air need to be left on when carrying out some task, be extremely careful to observe all safety precautions.

If you depress the treadle or the switches by mistake, it will cause the machine to operate, and injury may result.



Wash your hands thoroughly after carrying out this operation.

(*1) Use protective gloves which can withstand temperatures of 200°C and higher.

10 CLEANING

If the upper and lower edge control rollers and the end detection sensor do not operate correctly, it is possible that glue, dirt or other foreign particles are adhering to the reflector. In such cases, wipe off the foreign particles.

[Cleaning the nozzle reflector]

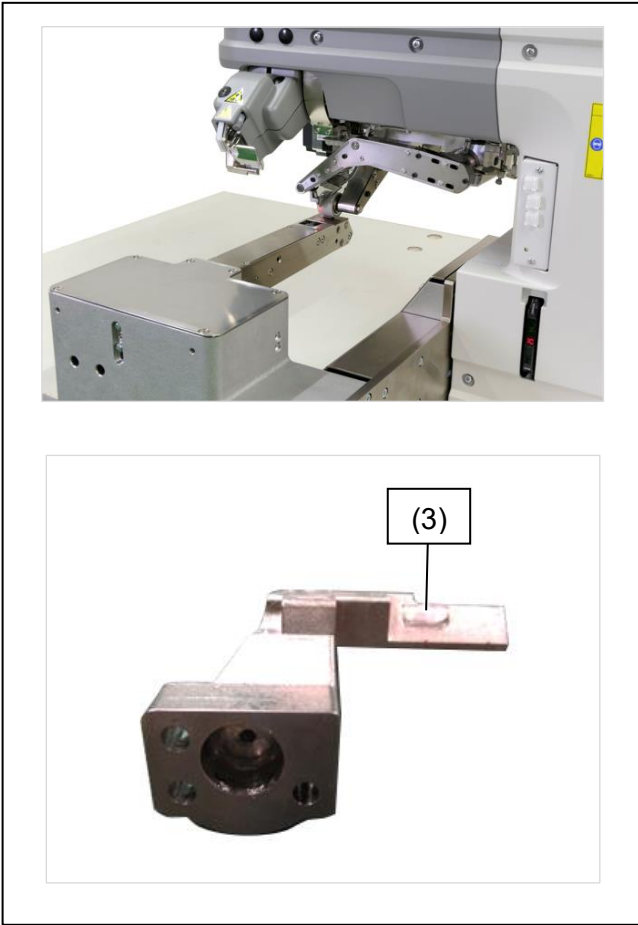

1. Press the  key to display the test screen.
2. Press the NOZZLE switch (1) to raise the nozzle (2) to the highest position.
3. Use a soft cloth to wipe off any glue, dirt or other foreign particles which are adhering to the reflector (3) of the nozzle (1).

NOTE:

- Do not wipe the reflector too firmly, otherwise it may peel off.
- Do not use any chemicals when wiping the reflector. They may damage the reflector and cause the edge control roller to stop working correctly.

[Cleaning the upper cloth plate reflector]



1. Press the  key to display the test screen.

2. Press the NOZZLE switch (1) to raise the nozzle (2) to the highest position.

3. Use a soft cloth to wipe off any glue, dirt or other foreign particles which are adhering to the reflectors (4) and (5) on the underside of the upper cloth plate (3).

NOTE:

- Do not wipe the reflector too firmly, otherwise it may peel off.
- Do not use any chemicals when wiping the reflector. They may damage the reflector and cause the edge control roller to stop working correctly.

10.6 Charging with cleaner

WARNING



When cleaning the glue path, wear protective gear such as protective goggles and protective gloves^(*1) to avoid exposure to your skin, and avoid letting the glue and the cleaner come into contact with your eyes and skin. If this is not observed, problems such as burns, inflammation or allergic reactions could result. Do not drink or eat the glue or the cleaner. If this is not observed, diarrhea or vomiting could result.



Wear a disposable dust mask to avoid inhaling the vapor from the glue and the cleaner. If this is not observed, problems such as respiratory difficulties or allergic reactions could result.



Keep the glue and cleaner out of the reach of children.



Use in an area with adequate ventilation, otherwise the vapors from the glue and the cleaner may accumulate and problems such as respiratory difficulties or allergic reactions could result.



Avoid drinking, eating and smoking while carrying out this operation. If the glue or cleaner is accidentally ingested, problems such as respiratory difficulties or allergic reactions could result.

CAUTION



If the power switch and air need to be left on when carrying out some task, be extremely careful to observe all safety precautions. If you depress the treadle or the hand switch by mistake, it will cause the machine to operate, and injury may result.



Wash your hands thoroughly after carrying out this operation.



Use only genuine Brother glue cartridges. Brother will not be held responsible for any accidents or problems resulting from the use of non-genuine parts.



Use only the cleaner specified by Brother. Brother will not be held responsible for any accidents or problems resulting from the use of a cleaner which is not specified by Brother.



(*1) Use protective gloves which can withstand temperatures of 200°C and higher.

Charge with cleaner at the following times.

- When replacing the nozzle
- If not using the machine for three days or more

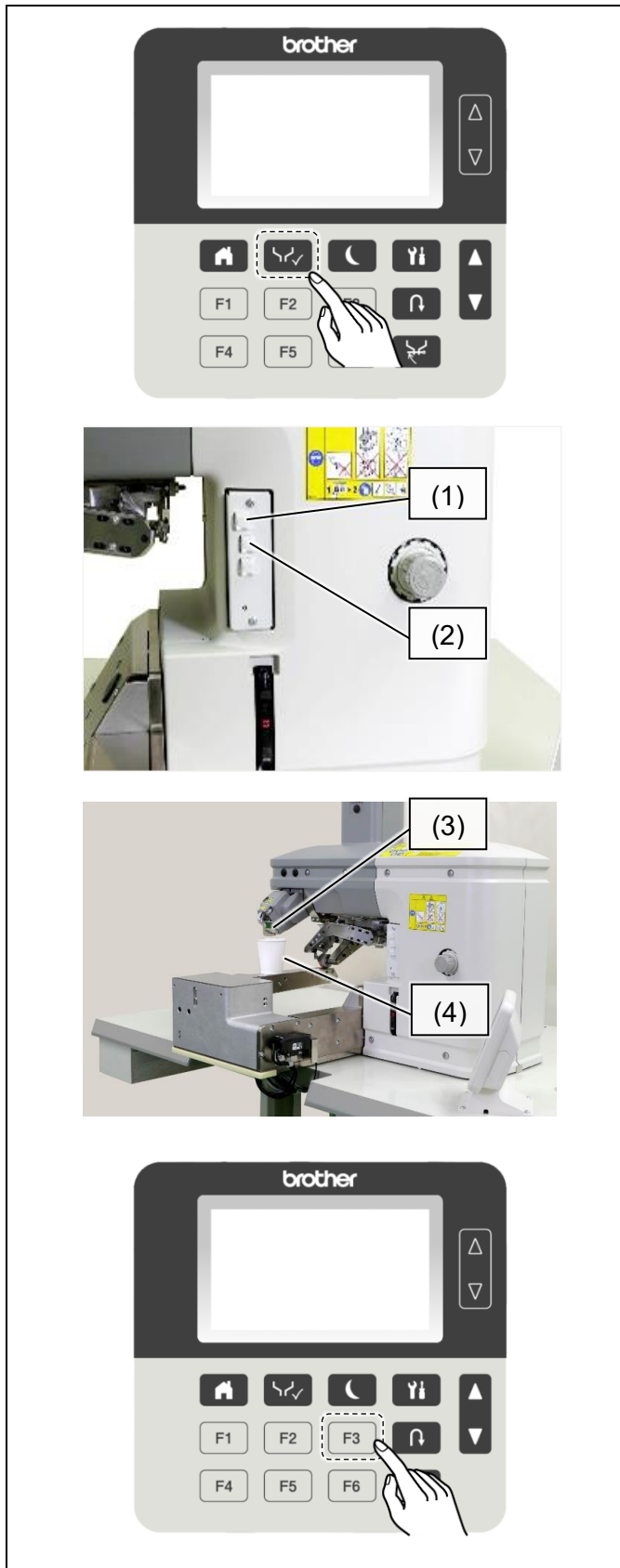
Use only the cleaner specified by Brother.



1. Refer to "9.2 Glue cartridge replacing method" for details on replacing the glue with cleaner.
2. Press the  key to display the test screen.
3. Press the NOZZLE switch (1) to raise the nozzle (3) to the highest position.
4. Place a dish such as a paper cup (4) for receiving a cleaner under the nozzle.
5. Press the  key to switch to automatic discharge mode.
(Refer to "4.2.2 Automatic discharge mode" for details on automatic discharge mode.)
6. Depress the treadle while pressing the GLUE ON/OFF switch (2) to start the discharge of glue from the nozzle (3). Cleaner will continue to be discharged for the length of time specified even after the treadle is released.
7. Once discharging of the cleaner is completed, use a cloth or similar to wipe off any cleaner which is adhering to the nozzle (3).

NOTE:

Follow all applicable regulations when disposing of the cleaner.

11 PART REPLACEMENT METHOD

11.1 Replacing the nozzle

NOTE:

If there is any glue remaining inside the nozzle, it may cause blockages, and it will not be possible to reuse the nozzle. Always be sure to charge the bonding machine with cleaner while referring to the procedure in "9.2" before replacing the nozzle.

1. Press the  key to display the test screen.

Temperature and pressure		↶
Melter (°C)	89.8	
Pump (°C)	119.4	
Nozzle (°C)	124.9	
Melter pressure (kPa)	262	
Pump pressure (MPa)	0.28	
Upper roller pressure (N)	15.5	
	0:00	

2. Press the NOZZLE switch to raise the nozzle to its highest position.
3. Remove the two screws.

NOTE: Parts may be hot, so be sure to wear protective gloves when carrying out this operation.

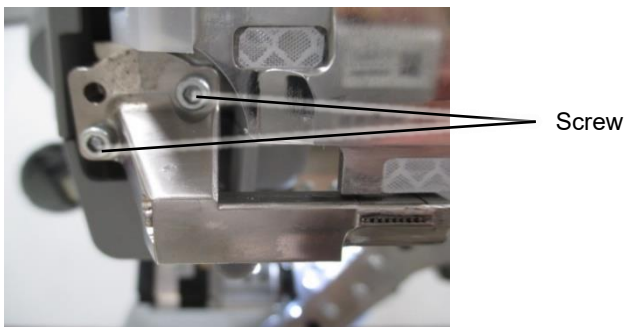

4. Remove the nozzle.

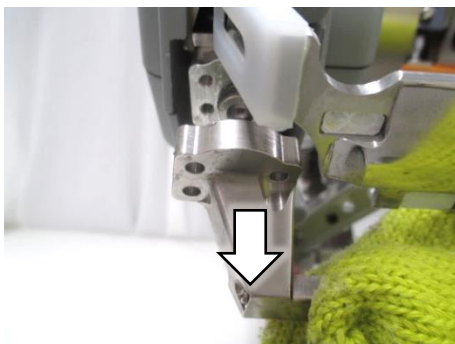

5. Install the new nozzle, and then provisionally tighten the two screws so that the nozzle can still be turned by hand.

NOTE: Take care so that the reflector on top of the nozzle does not peel off.

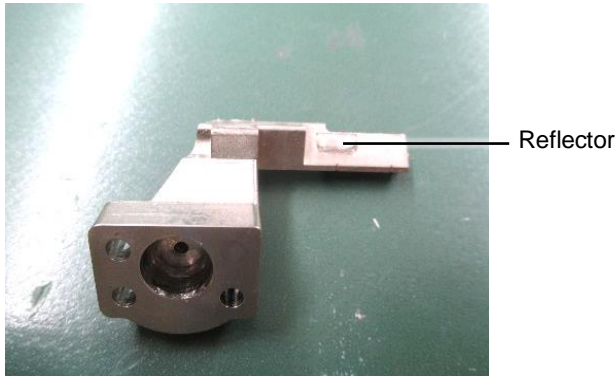

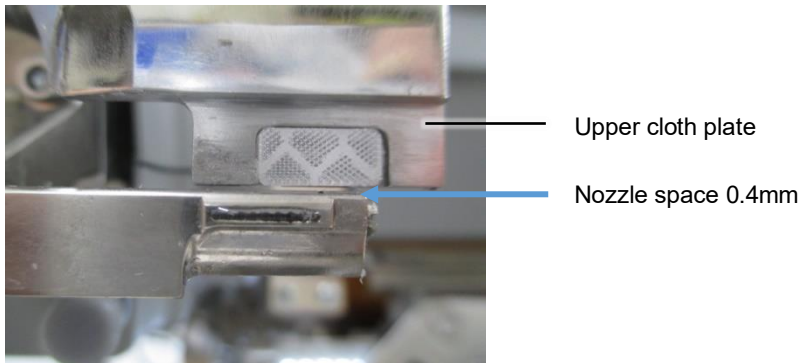

6. Adjust the amount of clearance between the nozzle and the upper cloth plate to 0.4 mm, and then fully tighten the two screws to secure the nozzle.

NOTE: If the nozzle and the upper cloth plate are touching, the upper cloth plate will become hot.

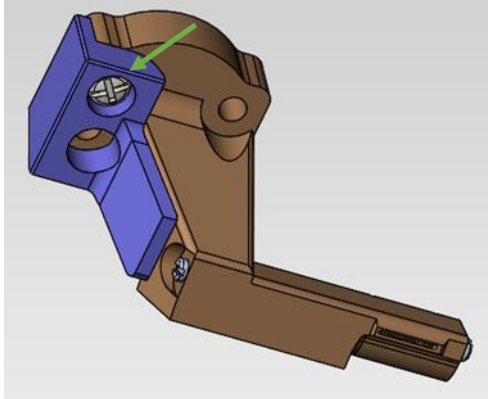

7. Remove the screw from the removed nozzle, and then remove the nozzle cover.



8. Use the removed screw to install the nozzle cover to the new nozzle.
9. Press the NOZZLE switch to lower the nozzle by one step.
10. Touch  to display the home screen.
11. If the gluing widths of the nozzle which was removed in step 4 and the nozzle which was installed in step 5 are different, adjust the upper roller position and the sensor position. Refer to "12.1.2" for details on the adjustment method.

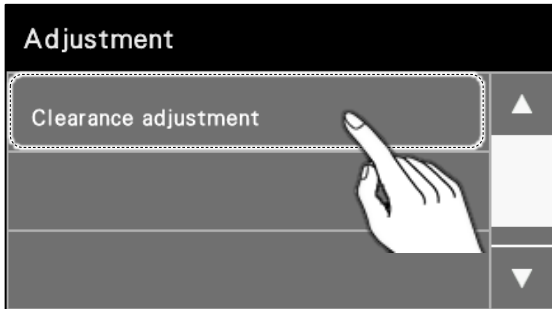

11.1.1 Nozzle clearance home position adjustment

1. While pressing the  key, turn on the power switch.
2. After carrying out steps 2 to 7 in "4.1 Starting the machine", touch ▼ which is displayed on the screen.
3. Touch "Clearance adjustment".

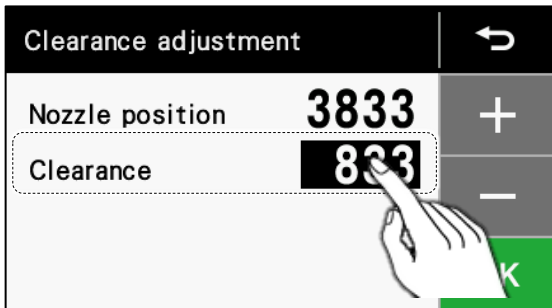

4. The following screen will be displayed, so touch "Clearance",
Adjust the nozzle position while referring to "11.1.2 Adjusting the nozzle position (feed direction)"



5. Insert a 0.5 mm thickness gauge in between the nozzle and the nozzle lower roller as shown in the image below, and then touch  or  to adjust the position of the nozzle lower roller. Once the amount of clearance between the nozzle and the nozzle lower roller is the same as the thickness gauge, touch .

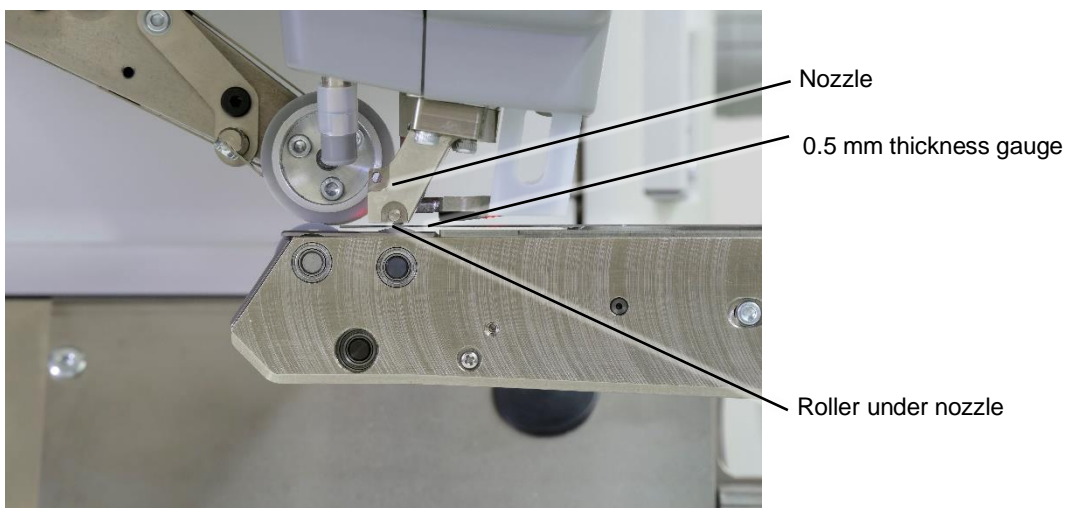

11.1.2 Adjusting the nozzle position (feed direction)

1. Display the memory switch setting screen. Refer to "3.5" for details on the display method.
2. Change the setting value for memory switch No. 411 so that the center of the nozzle screw is directly above the center of the nozzle lower roller shaft. The larger the value, the further forward the nozzle will move.

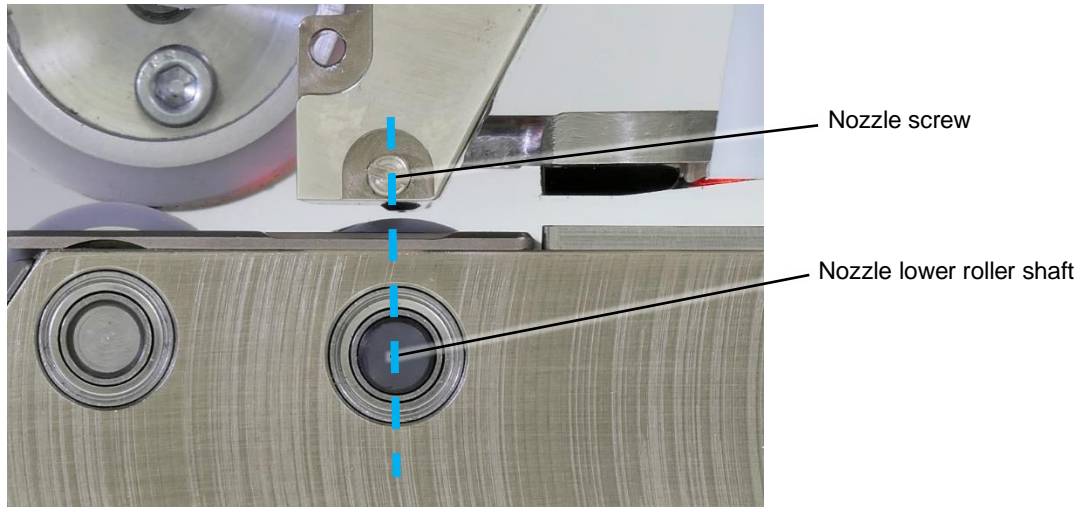

No.	Name	Details	Setting range	Step	Initial value
411	Nozzle lever application position correction	Correction amount for application position (position a)	-120~120	4	0

11.2 Replacing the lower roller

NOTE:

Be sure to turn off the power switch of the bonding machine and stop the supply of air before carrying out this procedure.

1. Remove the top cover (6 screws).

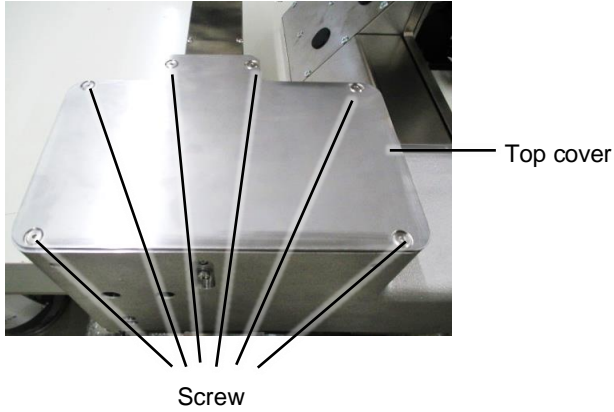

2. Remove the cloth plate. (It is secured by a magnet, so it can be removed by lifting it upward.)

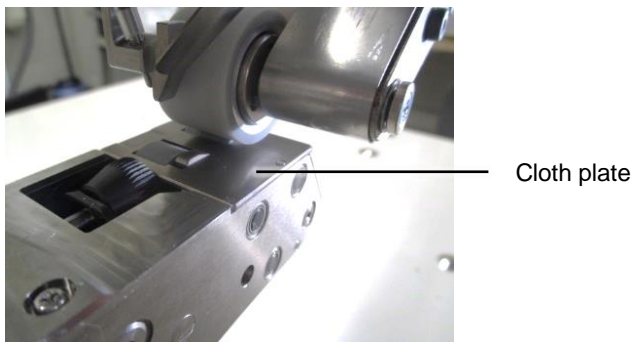

3. Remove the anti-entanglement plate (2 screws).

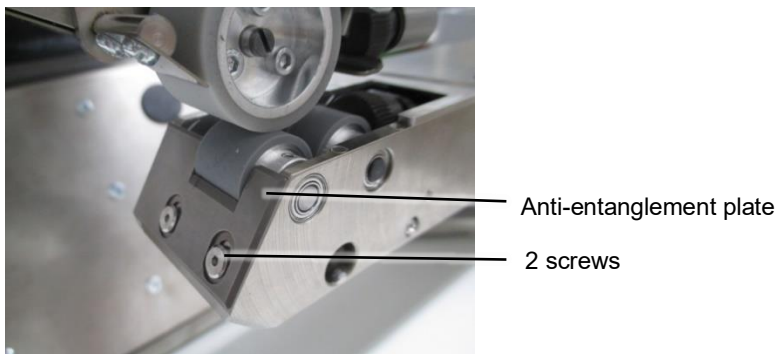

4. Loosen the three screws of the lower feed unit as shown in the illustration, and push the feed motor toward the back.

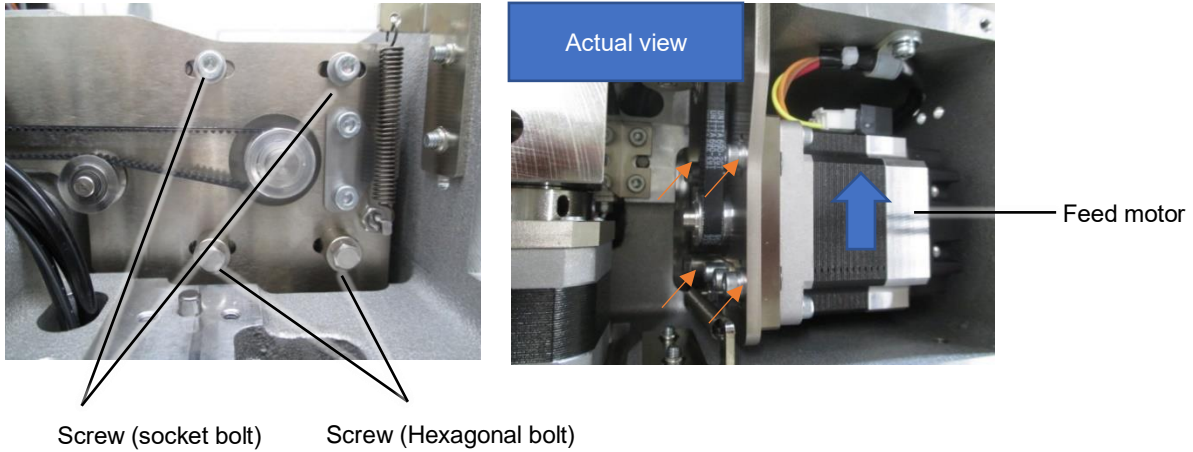

5. Loosen the set screws which are securing the lower roller and its drive pulley (in 2 places for each part).

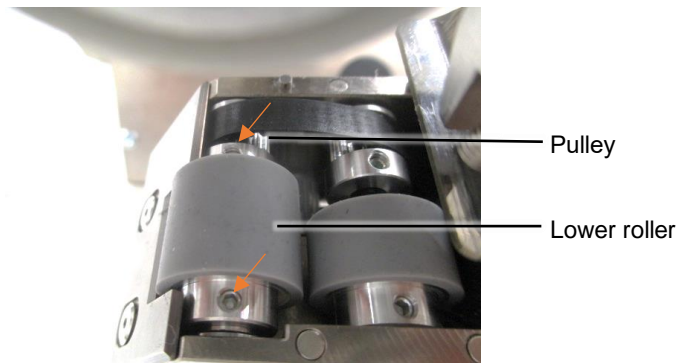

6. Move the lower roller shaft in the direction shown in the illustration and replace the lower roller.

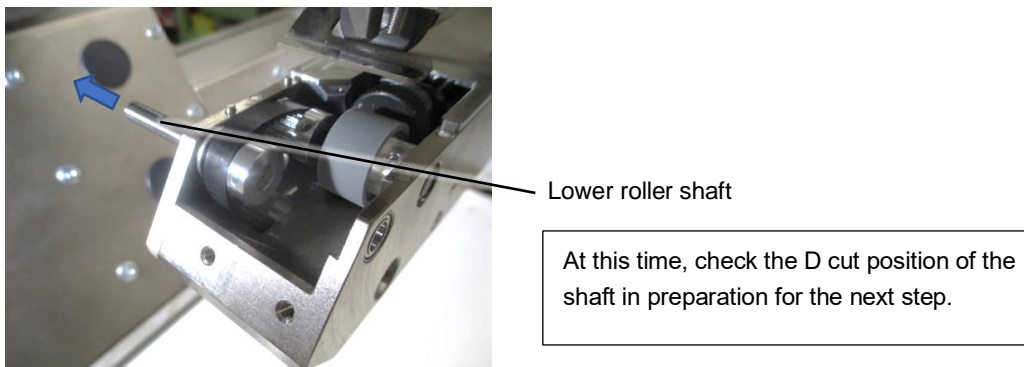

11 PART REPLACEMENT METHOD

- Align the left edge of the lower roller shaft with the edge of the bearing, and then secure the lower roller with the two two set screws. At this time, make sure that one of the set screws is securely against the D cut section of the shaft.

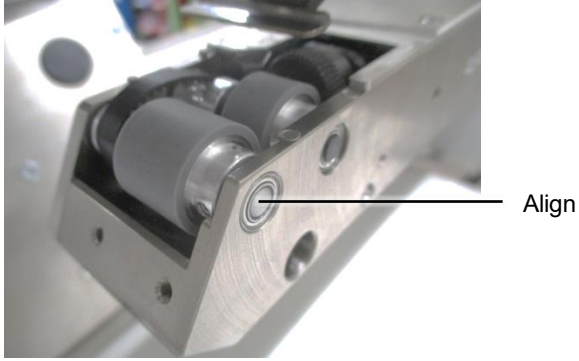

- Secure the drive pulley with the two set screws. At this time, secure the drive pulley so that one of the set screws is securely against the D cut section of the shaft and so that there is no play in the axial direction.
- Check that the timing belt is attached to the pulley in an appropriate position, and then while pulling the feed motor forward, fully tighten the three screws shown in the illustration.

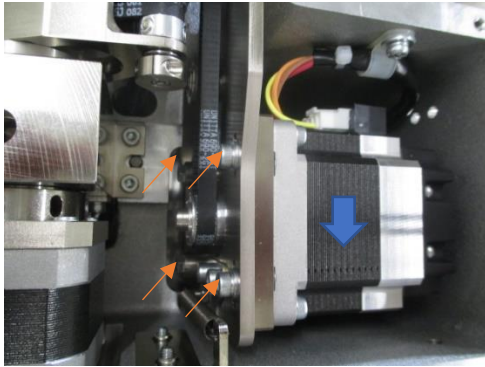

- Turn the lower roller by hand and check that the nozzle lower roller and the feed motor pulley turn correctly.
- Install the anti-entanglement plate, the cloth plate and the top cover.
 - * Adjust the position of the anti-entanglement plate while referring to "12.2 Adjusting the anti-entanglement plates".

12 STANDARD ADJUSTMENTS

12.1 Changing the gluing width

12.1.1 Replacing the nozzle

The gluing width can be changed by replacing the nozzle.

Three types of nozzle are available, with gluing widths of 6 mm, 8 mm and 10 mm.

Refer to "11.1 Replacing the nozzle" for details on replacing the nozzle.

12.1.2 Settings when changing the gluing width

Carry out the following procedures when installing a nozzle with a different gluing width.

[Changing the gluing width setting]

1. Display the memory switch setting screen. Refer to "3.5" for details on the display method.
2. Change the setting for memory switch No. 500 to match the gluing width for the nozzle which has been installed.

No.	Name	Details	Setting range	Step	Initial value
500	Nozzle gluing width	Gluing width of installed nozzle	6~10 [mm]	2	8

[Upper roller position adjustment]

1. Remove the three screws (1), and then remove the rear cover L (2).

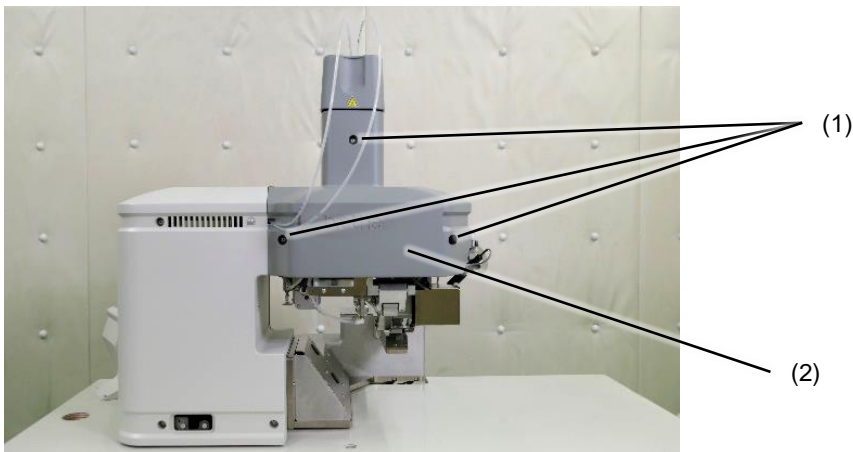

2. Loosen the three screws (3).

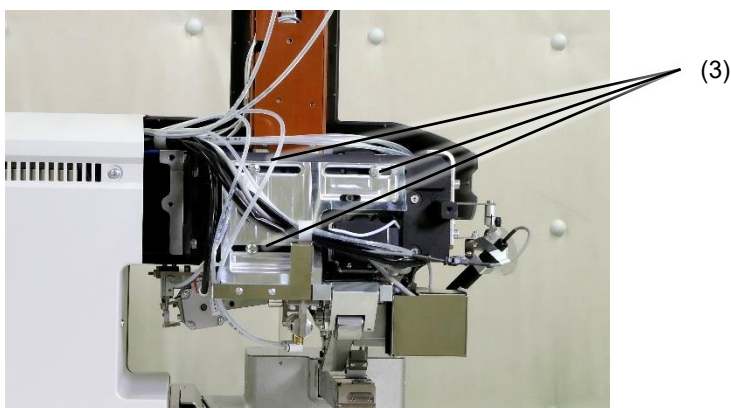

12 STANDARD ADJUSTMENTS

- Adjust the sideways position of the upper feed mechanism so that the distance between the edge of the upper roller and the edge of the arm is as given below.

6mm Nozzle: 13.4mm, 8mm Nozzle: 11.4mm, 10mm Nozzle: 9.4mm

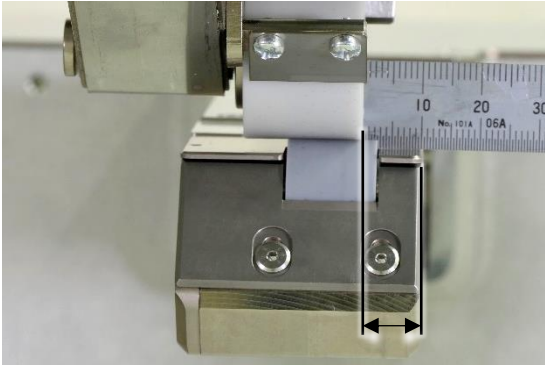

- Tighten the three screws (3) which were loosened in step 2.
- Install the rear cover L (2) which was removed in step 1.

[Sensor position adjustment]

- Loosen the screw (5) of the sensor support (4).

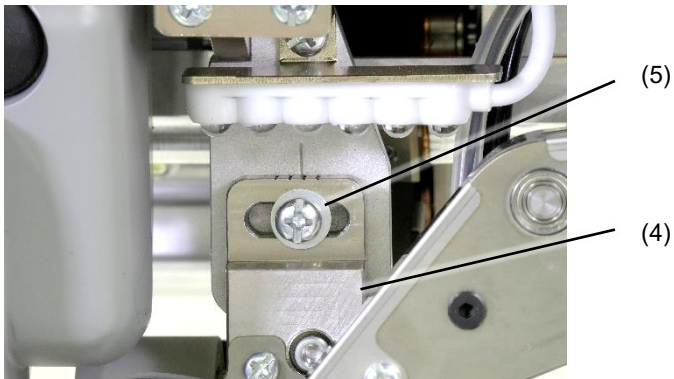

2. Press the NOZZLE switch to move the nozzle to its lowest position. After this, adjust the sideways position of the sensor support (4) so that the groove on the left side of the nozzle and the center of the sensor are aligned.

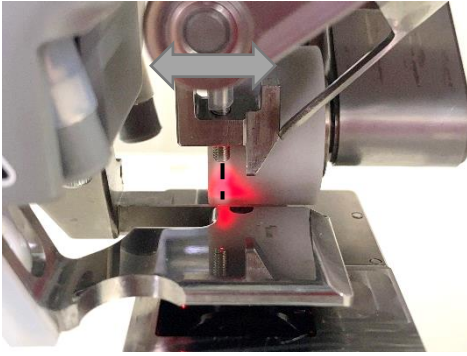

There are grooves near the screw (5) of the sensor support to use as a guide for positioning. For example, if the nozzle with a 10 mm gluing width is installed, adjust the position of the sensor so that the reference line and the 10 mm line are aligned.

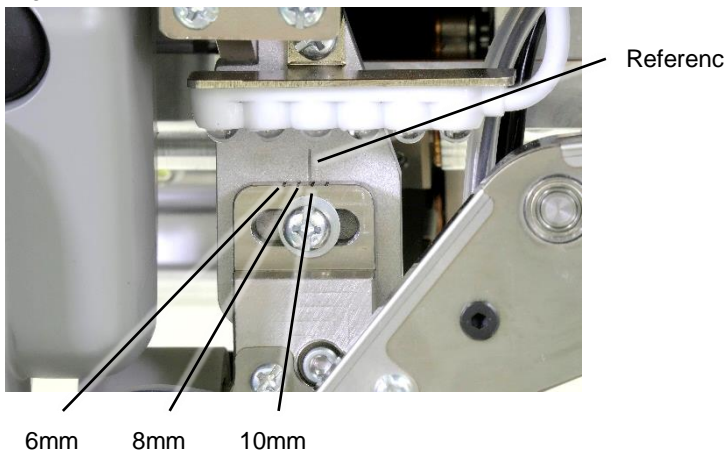

3. Tighten the screw of the sensor support.

12.2 Adjusting the anti-entanglement plates

12.2.1 At lower roller side

1. Loosen the two screws (3) of the anti-entanglement plate (2) which are located at the bottom of the lower roller (1).

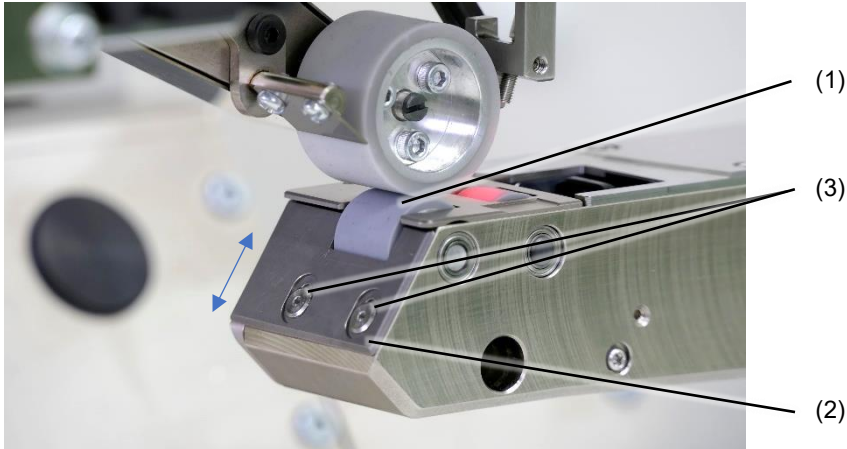

2. Adjust the position of the anti-entanglement plate (2) so that the clearance between the lower roller (1) and the anti-entanglement plate (2) is as small as possible (around 0.1 mm) without the two parts touching.
3. Tighten the screws (3) to secure the anti-entanglement plate (2).

12.2.2 At upper roller side

1. Loosen the two screws (5) at the upper roller (4).

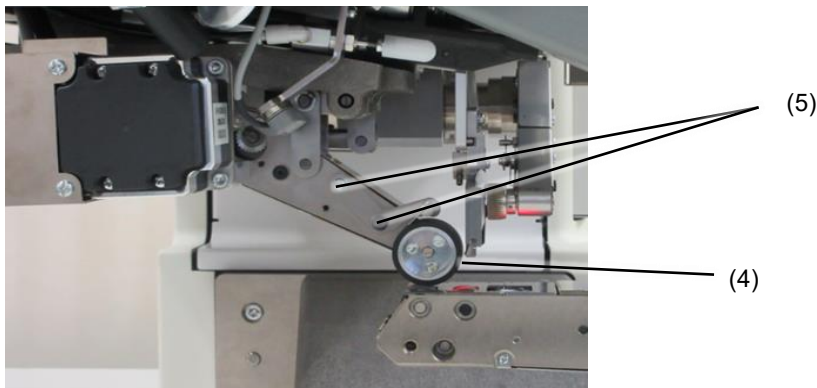

2. Adjust the position of the anti-entanglement plate (6) so that the clearance between the upper roller (4) and the anti-entanglement plate (6) is as small as possible (around 0.1 mm) without the two parts touching.

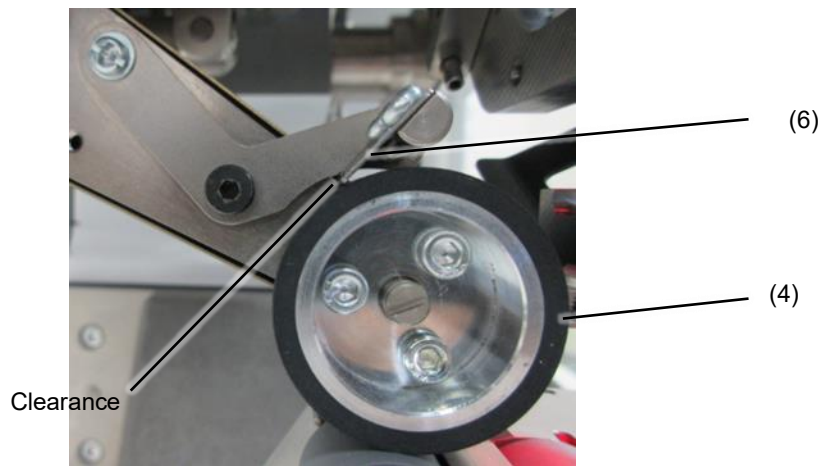

3. Tighten the screws (5) to secure the anti-entanglement plate (6).

12.3 Adjusting the upper cloth and lower cloth sensor amplifiers

12.3.1 Summary

Adjust the upper cloth and lower cloth sensor amplifiers.

This bonding machine uses the following three types of amplifier.

- Upper cloth sensor amplifier FS-N11MN (1)
- Lower cloth sensor amplifier FS-N11MN (2)
- End detection sensor amplifier FS-N11N (3)



The names of the amplifier parts are shown below.

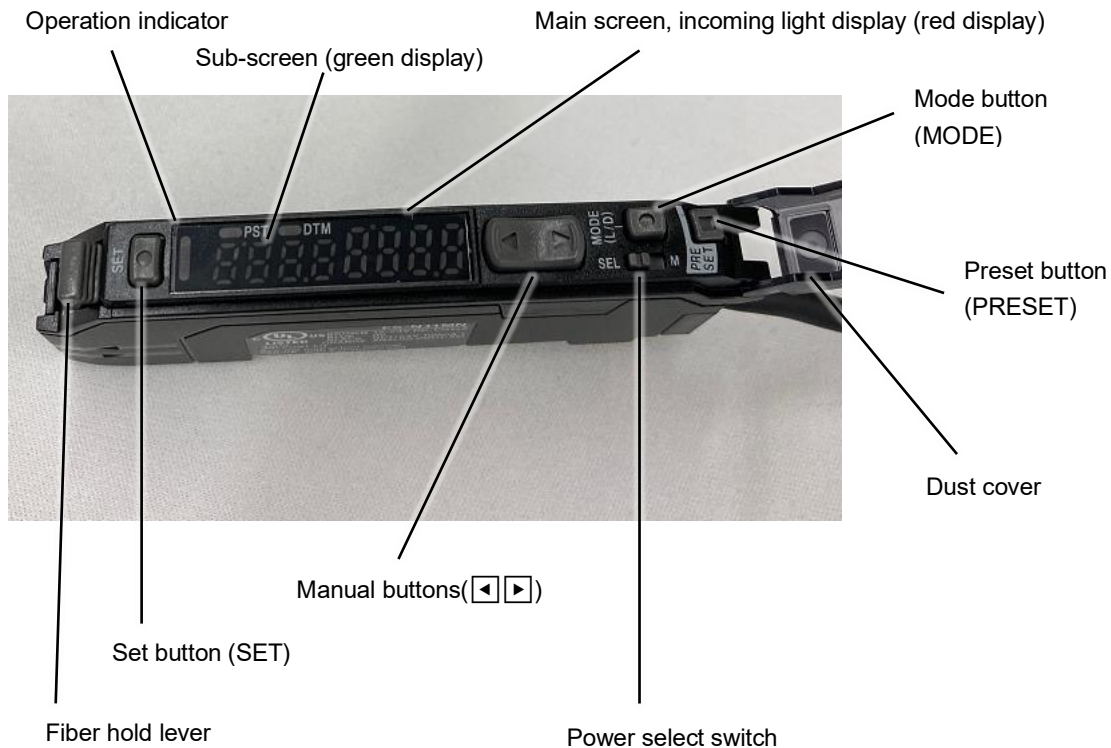

NOTE:

- Do not touch the end detection sensor amplifier.
- If the sensor emitters, the areas around them or the reflectors become dirty, the amount of incoming light will drop, and there may not be enough incoming light to set the necessary light intensity. In such cases, clean the affected areas and then carry out adjustments.

12.3.2 Setting the light intensity

Carry out this adjustment without setting any cloth in place.

1. Turn on the power switch to start the bonding machine.
2. Press the NOZZLE switch to lower the nozzle to its lowest position.
3. Check the values for the upper cloth and lower cloth sensor amplifiers in the incoming light display. Check that the incoming light display for both amplifiers is within the range of 3500 to 4000. If they are outside this range, carry out the operations in the following steps 4 and 5.
4. Operate the upper cloth and lower cloth sensor amplifiers as described below, and display "Switch emitter power" to adjust the values. Adjust the emitter power so that the values appearing in the incoming light display of the amplifier are within the range of 3500 to 4000.

NOTE: Set the emitter power to 70 or less.

12 STANDARD ADJUSTMENTS

■Basic Setting

Press and hold (MODE) for 3 seconds or more

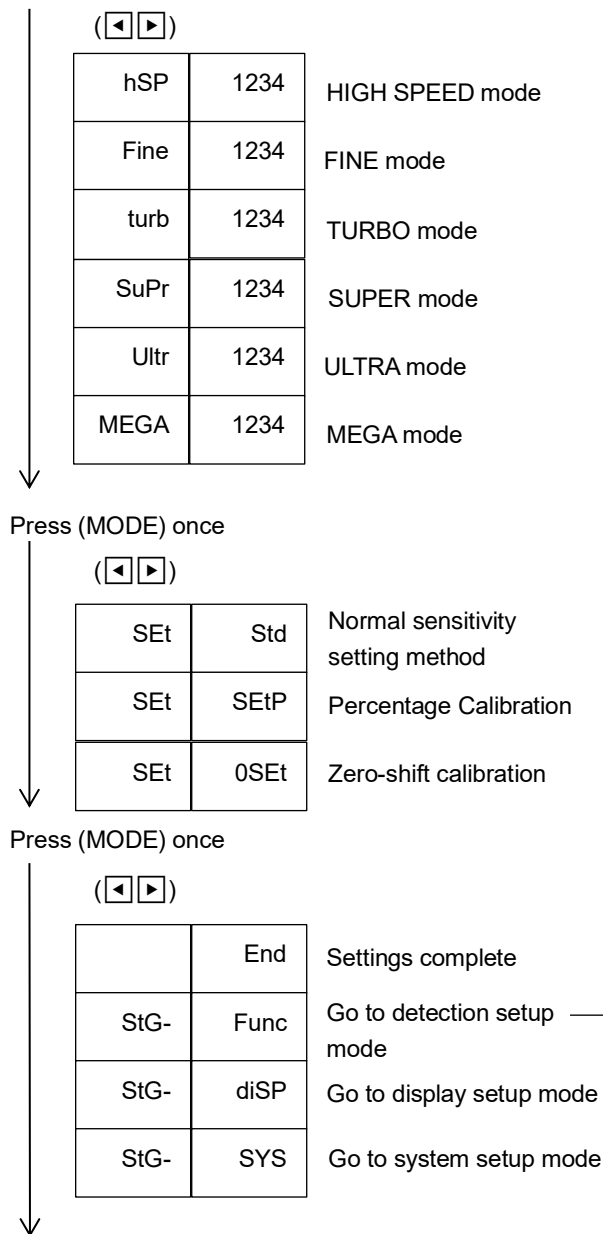

Press (MODE) to return to normal display

■Detection Settings

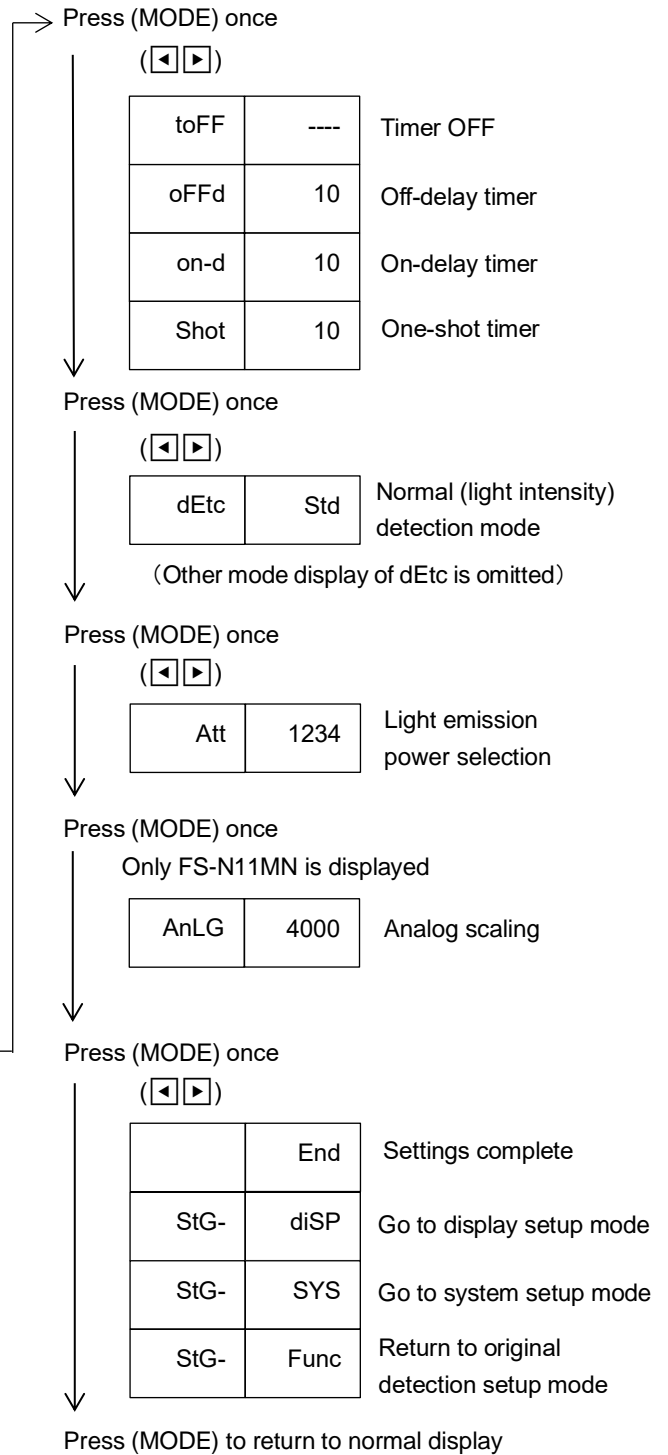

5. Press the MODE button to return to the normal display.

12.4 Adjusting the positioning LED marker

Adjust the LED marker which is used for positioning when setting the cloth at the start of gluing.

[Preparation before adjustment]

1. Turn on the power switch to start the bonding machine.
2. Depress the treadle once so that the positioning LED marker (1) illuminates.

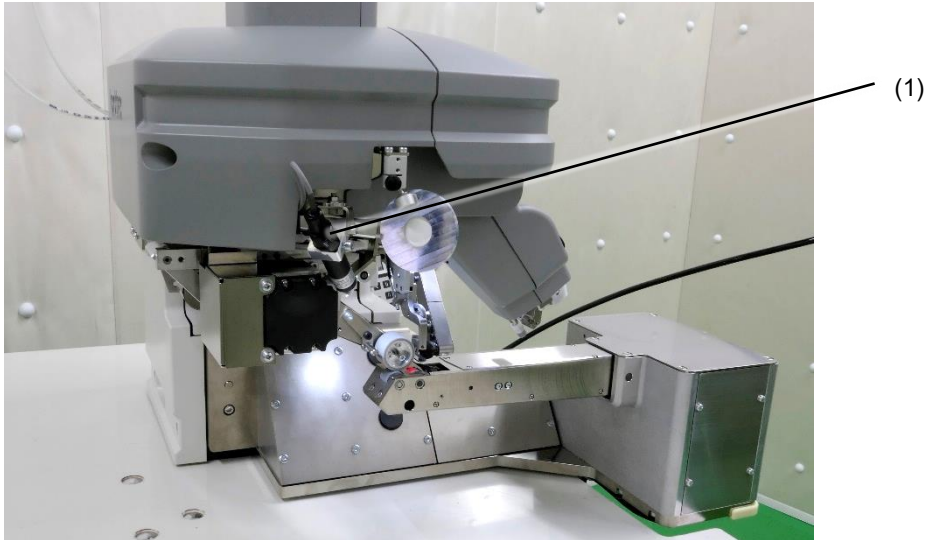

[Positioning LED marker position adjustment]

1. Loosen the three screws (2).

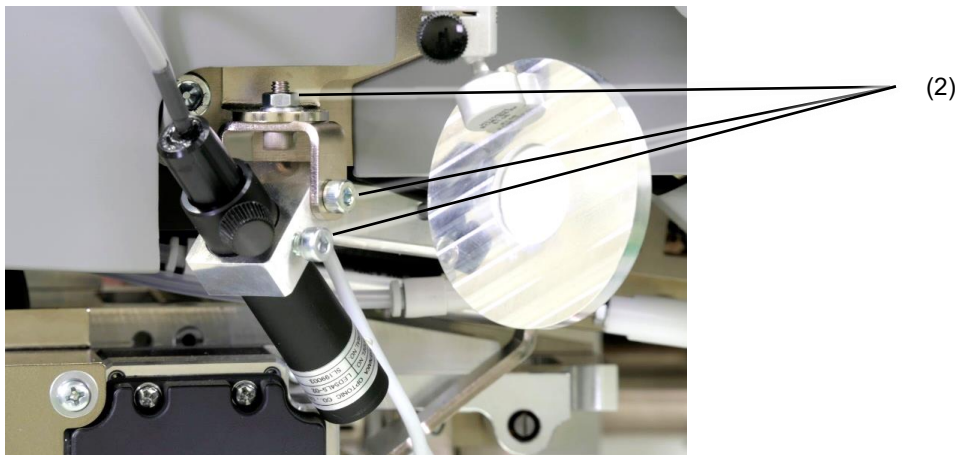

12 STANDARD ADJUSTMENTS

2. Adjust the position of the positioning LED marker (1) so that the irradiation position is as shown in the following illustration.

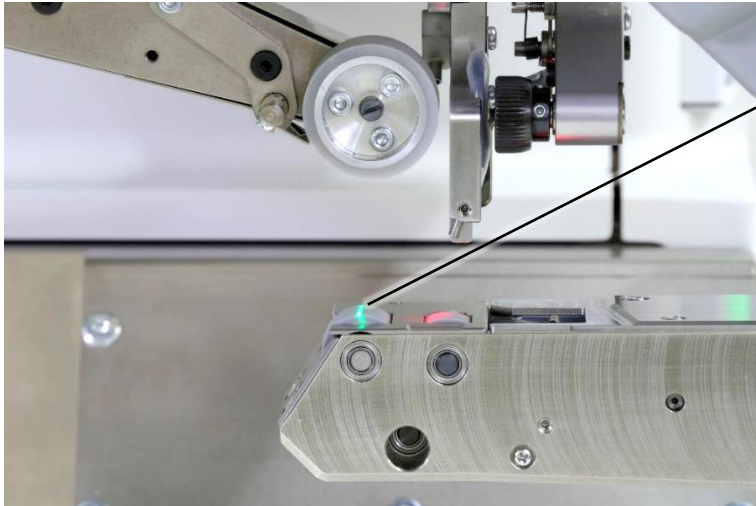

Irradiation position
for positioning LED
marker

3. Tighten the screws which were loosened in step 1. Be careful not to tighten the screws too much.

[Positioning LED marker focus adjustment]

1. Loosen the knob screw (3), move the positioning LED marker (1) in or out to adjust the focus position, and then tighten the knob screw (3) to secure the positioning LED marker (1).

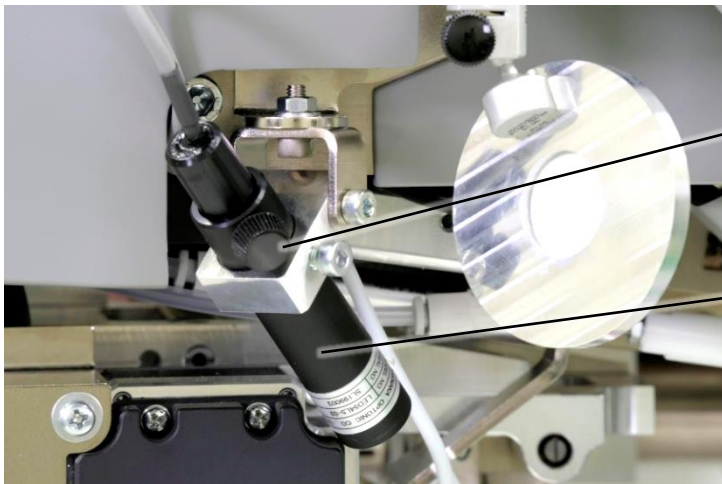

(3)

(1)

[Positioning mirror adjustment]

1. Loosen the knob screw (4), move the positioning mirror (5) to adjust so that the irradiation position of the positioning LED marker is near the center, and then tighten the knob screw (4) to secure the positioning mirror (5).



(4) Knob screw

(5)

12.5 Adjusting the sideways position of the lower edge control sensor

1. Loosen the screw (1), and then remove the bottom cover (2).



2. Use a mirror to view from underneath.

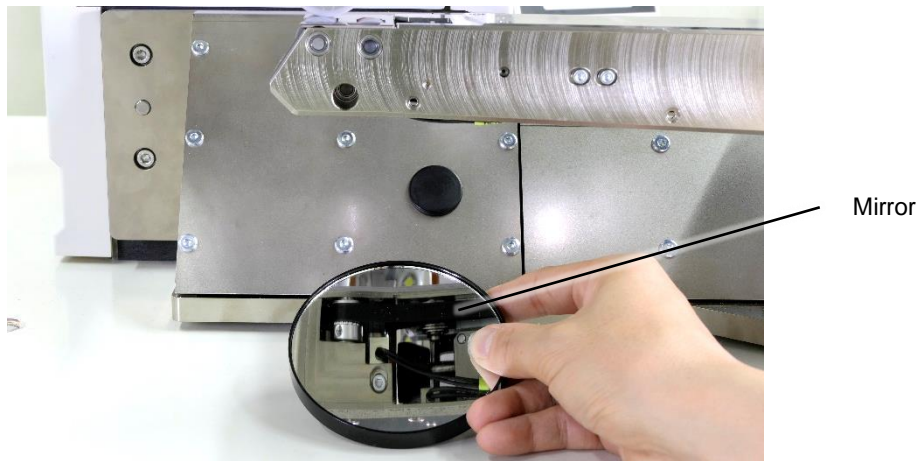

12 STANDARD ADJUSTMENTS

- Loosen the screw (3), and then move the sensor bracket (6) so that the reference line on the sensor bracket (4) is aligned with the edge of the arm (5).

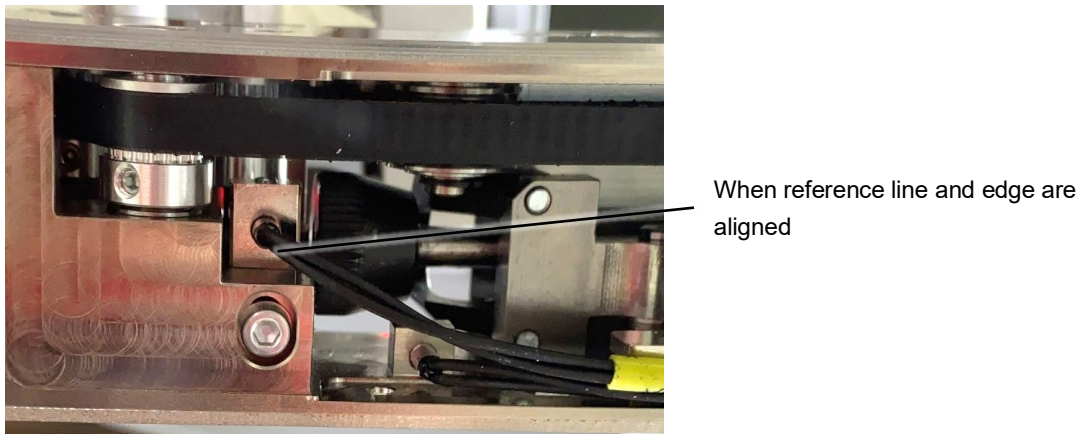
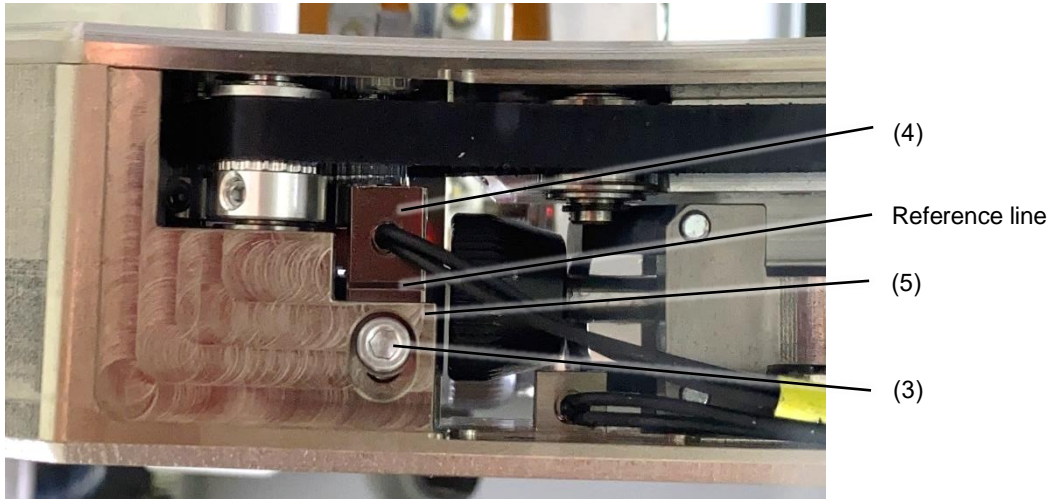



- Tighten the screw (3).
- Install the bottom cover (2).

12.6 Setting the treadle stroke

Set the treadle stroke amount.

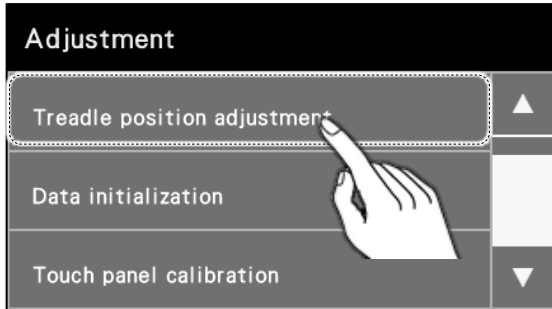
1. While pressing the  key, turn on the power switch.
2. Touch "Treadle adjustment".



3. With the treadle depressed all the way forward, wait until the voltage value display stabilizes and then touch  .

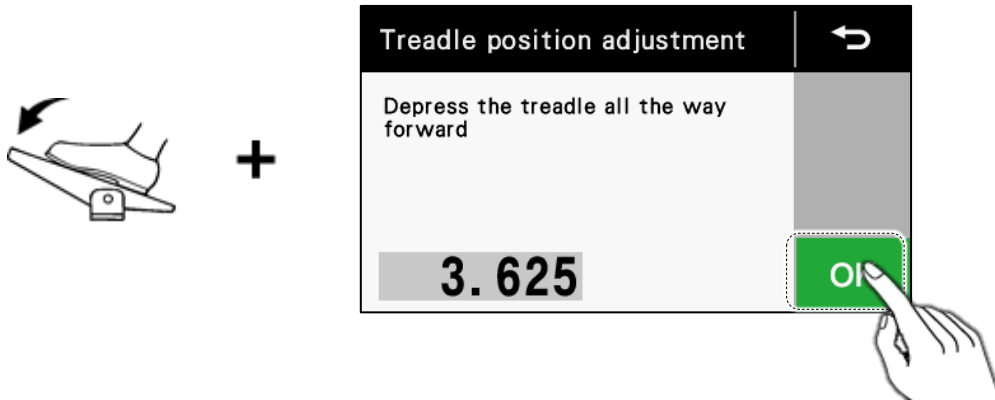

4. With your foot released from the treadle, wait until the voltage value display stabilizes and then touch  .

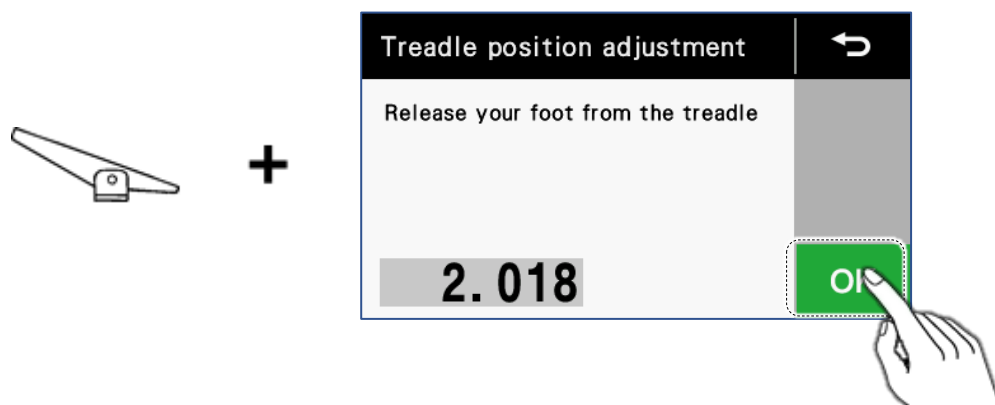

12 STANDARD ADJUSTMENTS

5. With the treadle depressed all the way backward, wait until the voltage value display stabilizes and then touch **OK**.

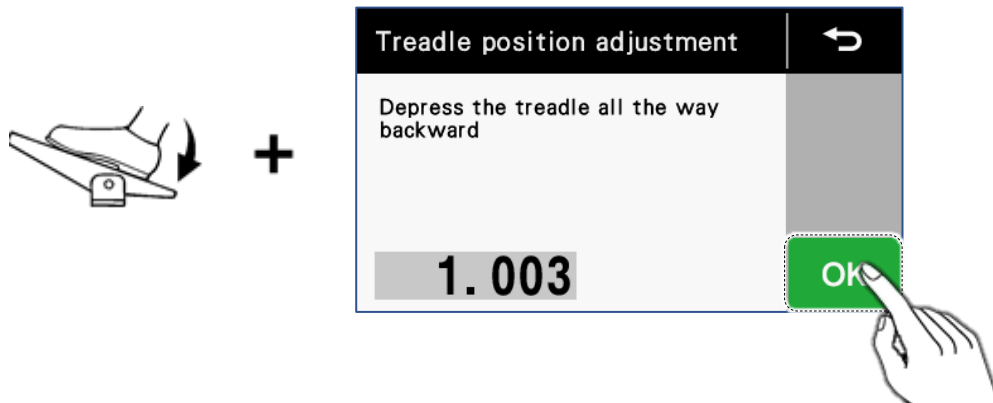

6. A screen will be displayed to show that the setting is complete.
Touch **OK** to display the setting menu screen

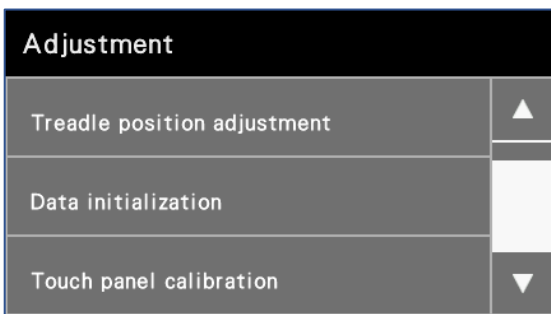
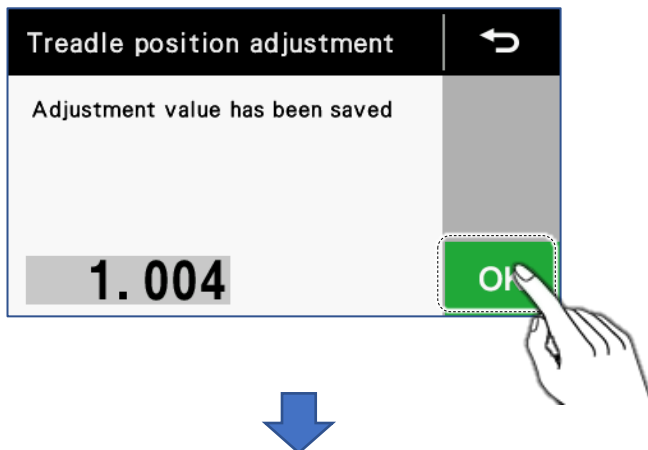

NOTE:

If the treadle is not operated correctly, the following screen will be displayed and a buzzer will sound.

If this happens, repeat the procedure from step 3.

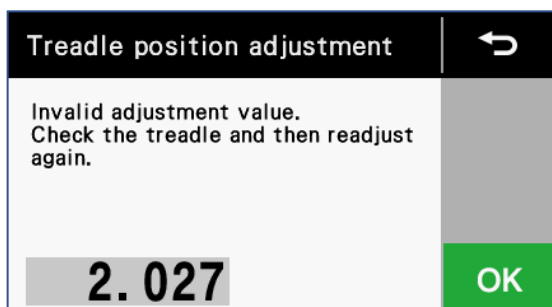

12.7 Adjusting the touch panel key positions

If the touch panel key reading coordinates and the touch key (icon) display positions do not correspond, carry out the following adjustment.

1. While pressing the  key, turn on the power switch.
2. Touch "Touch panel calibration".

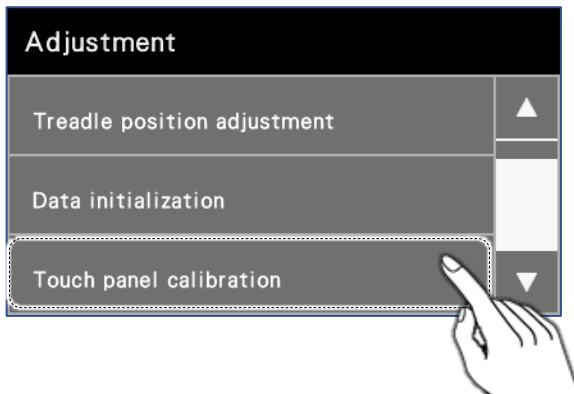

3. The touch panel key position adjustment screen will be displayed.
The following procedure reads the coordinates at four places on the screen.
Carry out the following operations using a touch pen or similar to press the positions accurately.

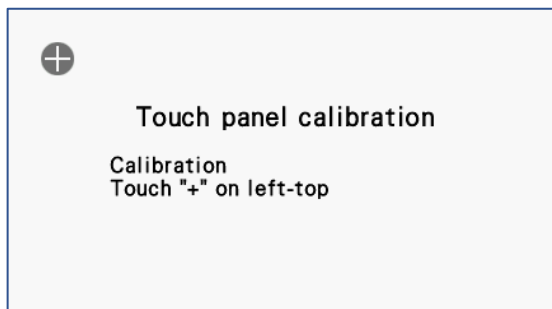

4. Press the center of the "+" mark in the top-left corner.
If the coordinates which are read are within the allowable range, the next screen is displayed.
If the error is outside the allowable range, the buzzer will sound twice, so repeat the operation.
5. Press the center of the "+" mark in the bottom-left corner.

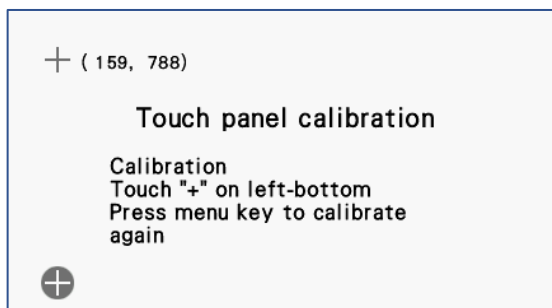

12 STANDARD ADJUSTMENTS

6. Press the center of the "+" mark in the bottom-right corner.

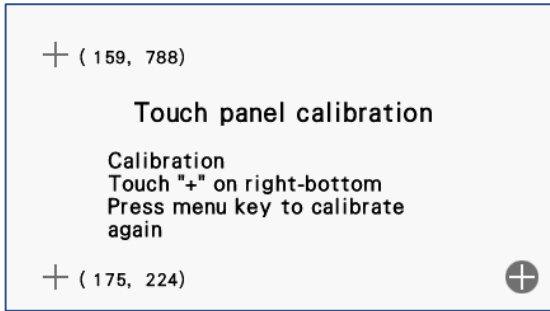

7. Press the center of the "+" mark in the top-right corner.

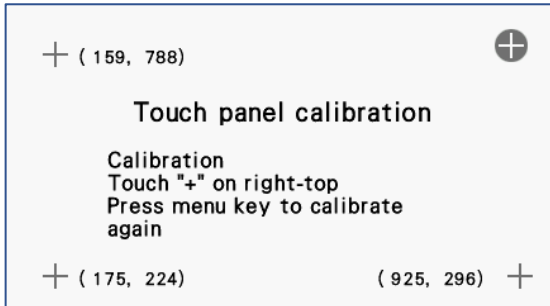

8. The following procedure measures the error between the coordinates at the centers of the keys and the coordinates which are read at four places on the screen.

Press the center of the "+" mark at the center-top.

If the error is within the allowable range (-5 to +5), the next screen is displayed.

If the error is outside the allowable range, the buzzer will sound twice, so repeat the operation.

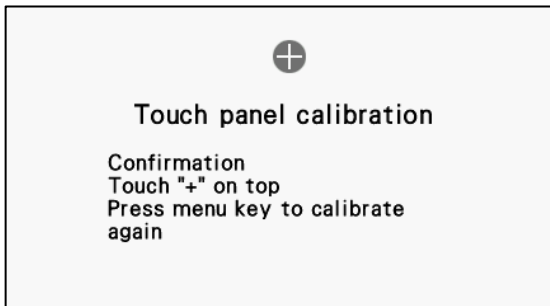

9. Press the center of the "+" mark at the center-left.

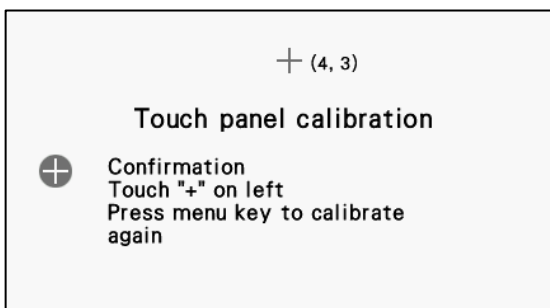

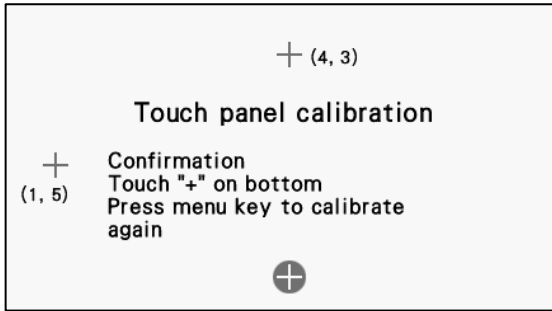

10. Press the center of the "+" mark at the center-bottom.

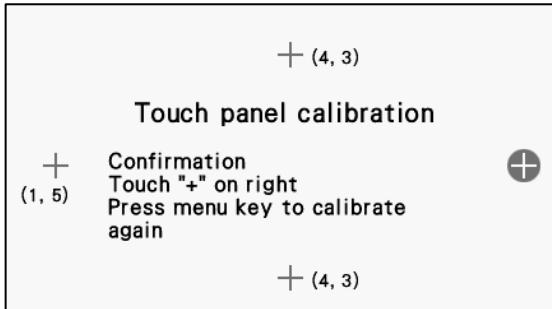

11. Press the center of the "+" mark at the center-right.



12. To confirm the adjustment values and exit, press the  key.

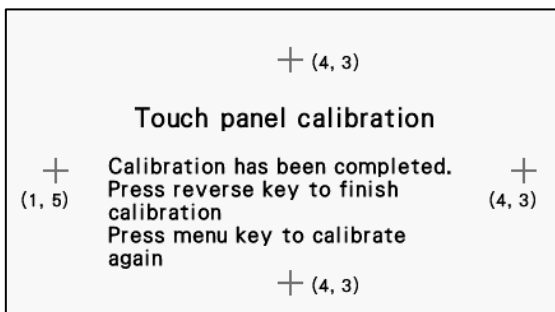

If you would like to repeat the procedure from the beginning, press the  key. (The display will return to step 3.)



13. Once the adjustment values have been saved, turn off the power.



12.8 Protect settings

1. While pressing the  key, turn on the power switch.
2. Touch  to switch the page, and then select "Protect setting".

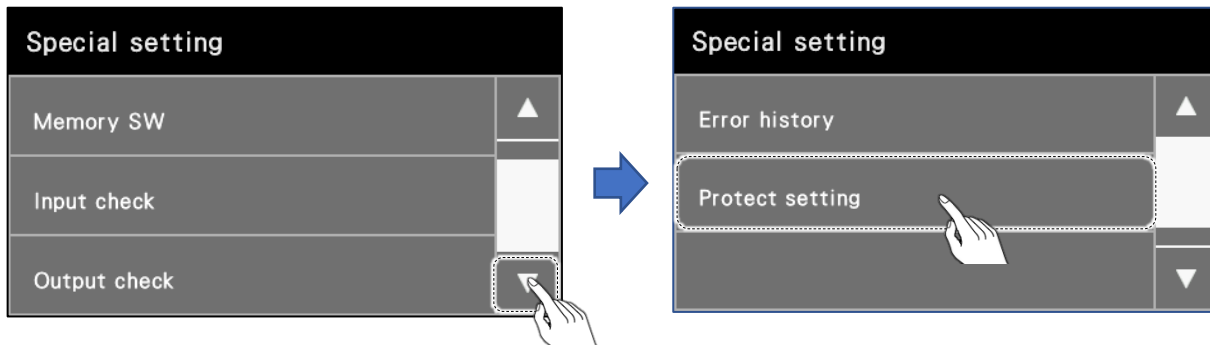

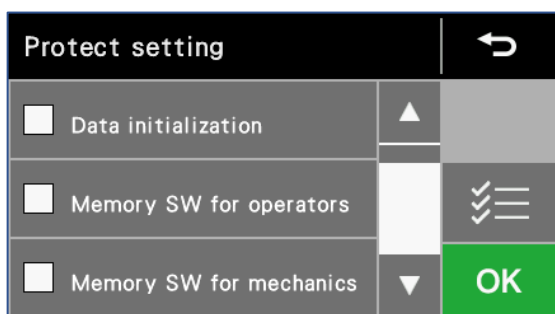

3. The "Protect setting" screen will be displayed.



12.8.1 Setting protection for each function individually

Protect settings can be enabled and disabled individually for each function*.

* Refer to "12.8.3" for details.

1. Touch  or  to select the protection item.

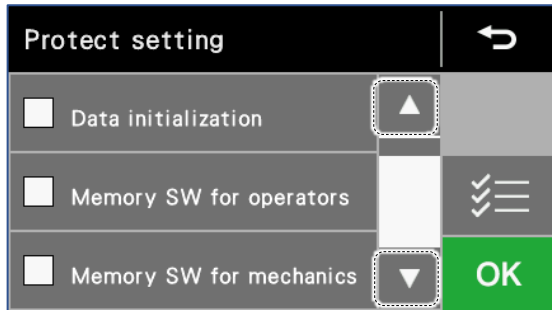

2. Touch an item, and then select whether to enable or disable protection for that item.

- Protect setting is enabled (changing settings is not allowed)
- Protect setting is disabled (changing settings is allowed)

3. Touch  to confirm the protect setting.



12 STANDARD ADJUSTMENTS

12.8.2 Selecting all items to disallow changing them

You can turn protection on for all functions by following the operation below.

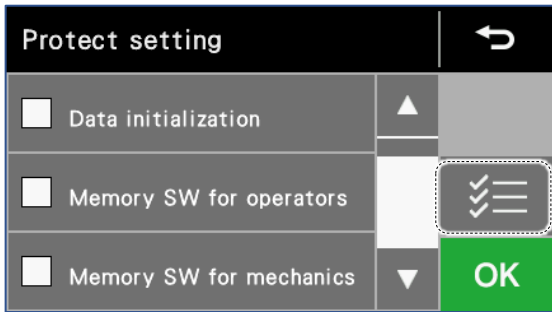
1. At the "Protect setting" screen, touch .



2. All items will have a check mark  against them.
* You can clear all of the check marks by touching  again.

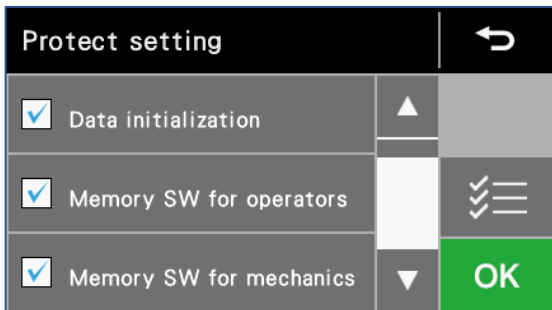

3. Touch  to confirm the protect setting.

12.8.3 List of functions that can be protected

Item name	Operation when protect setting is enabled
Data initialization	Data initialization in the adjustment menu is not allowed.
Memory SW for operators	Setting of memory switches for operators in the setting menu is not allowed.
Memory SW for mechanics	Setting of memory switches for technicians in the setting menu is not allowed.
Change Program No.	Selecting the program selection screen in the home screen and changing program numbers are not allowed.
Program Setting	Selecting the following screens from the home screen is not allowed. <ul style="list-style-type: none"> ▪ "Glue thickness setting" ▪ "Nozzle clearance setting" ▪ "Step selection/editing" ▪ "Roller feed speed setting" ▪ "Glue-free width setting" ▪ "Anti-stop mark setting" ▪ "Comment setting"
Production Counter	Production counter settings in the setting menu and home screen are not allowed.
End detection	Turning the end detection sensor on and off in the home screen is not allowed.
Treadle adjustment	Treadle position adjustment in the adjustment menu is not allowed.
Clearance adjustment	Nozzle clearance adjustment in the adjustment menu is not allowed.
Touch panel calibration	Touch panel key position adjustment in the adjustment menu is not allowed.
Program copy	Program copy operations in the setting menu are not allowed.
Cartridge exchange	Cartridge replacement in the setting menu is not allowed.
Data read	The following data reading and writing items in the setting menu and special menu are not allowed. <ul style="list-style-type: none"> ▪ Read all data ▪ Read program ▪ Read memory SW
Data write	The following data reading and writing items in the setting menu and special menu are not allowed. <ul style="list-style-type: none"> ▪ Write all data ▪ Write program ▪ Write memory SW ▪ Write Error Log

* If the protect settings have been enabled for both reading of data and writing of data, Data reading and writing items in the setting menu and special menu are not allowed.

12.9 Installing the flat bed

1. Loosen the two screws (1), and then remove the anti-entanglement plate (2).



2. Use the screws (1) which were removed in step 1 to install the anti-entanglement plate support (3)

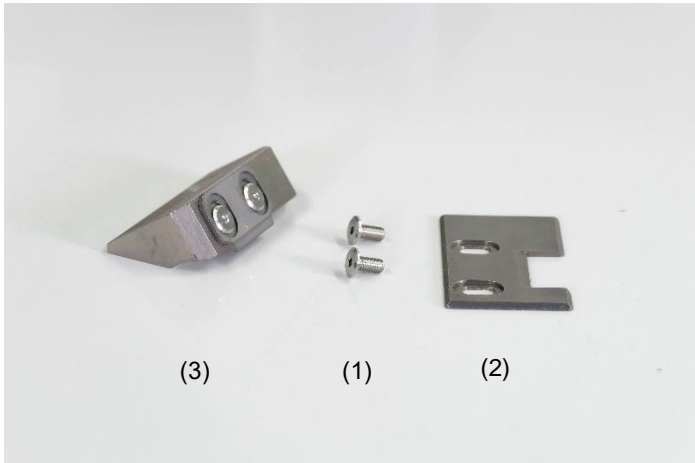

3. Loosen the two screws (4).
Move the anti-entanglement plate (5) which is installed to the anti-entanglement plate support (3) back and forth to adjust its position so that the clearance between the lower roller (6) and the anti-entanglement plate (5) is as small as possible (around 0.1 mm) without the two parts touching.

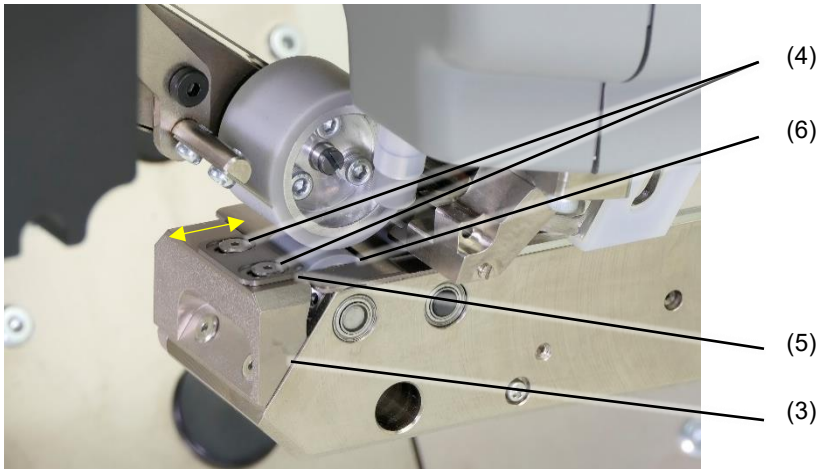

4. use the two M5 screws with washer (7) to install the mounting stay (8) to the frame.

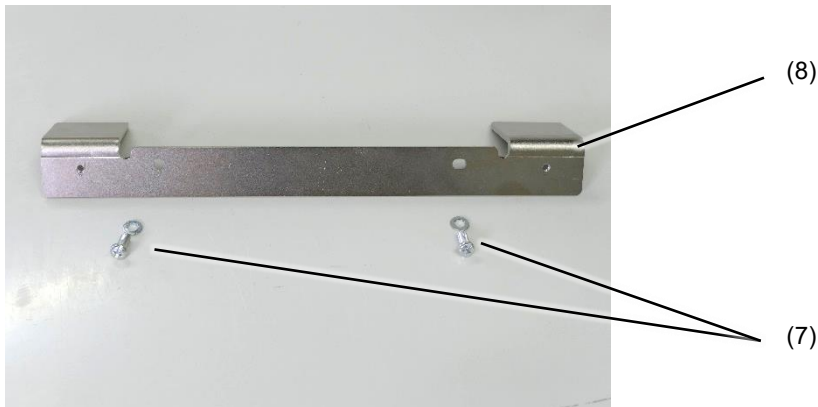

12 STANDARD ADJUSTMENTS

5. Raise the nozzle lever (9) and the upper edge control roller (10). Push the flat bed (11) from the back until it covers the mounting stay (8), and then secure it by tightening the two M4 screws with washer (12).

At this time, be careful that the flat bed (11) is not lifted up from the mounting stay (8).

* To remove the flat bed, follow the installation procedure in reverse.



6. You can adjust the clearance between the bottom of the nozzle (14) and the flat bed (11) by adjusting the height of the leg pad (13).

Loosen the nut (15), turn the nut (16) to adjust the height of the leg pad (13), and then tighten the nut (15).

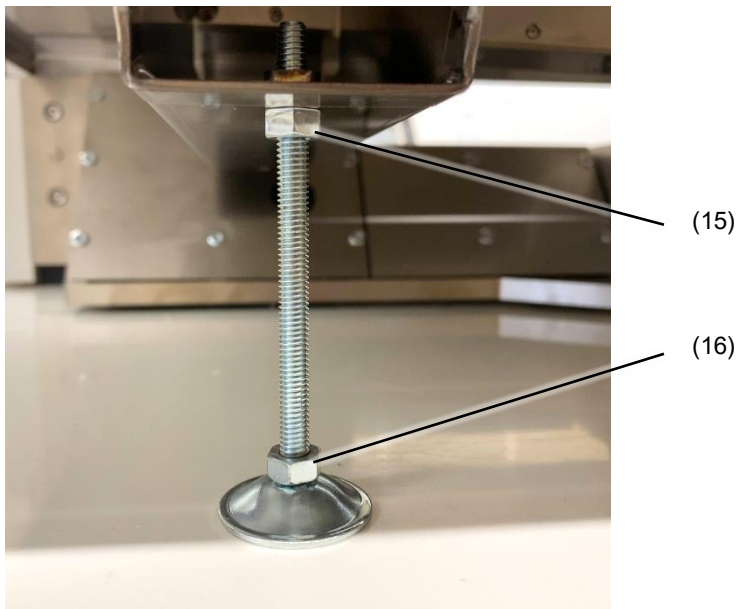

13 SOFTWARE UPGRADE

13.1 Preparation

1. Create the following folder in the USB media.
¥BROTHER¥ISM¥ISMSYS
2. Copy the version upgrade file into the folder which you created.

Name	Filename
Panel control	ISM27PL.upf
Main control	ISM27MN.BVP
Expansion control	ISM27EX.BVP
Temperature adjustment control	ISM27TC.BVP

13.2 Software upgrade

1. Insert the power plug into an electrical outlet, and stop the supply of air.
2. Insert the USB media which was created in 13.1 into the USB port at the side of the operation panel.
3. While pressing the  key, turn on the power switch to display the following screen.

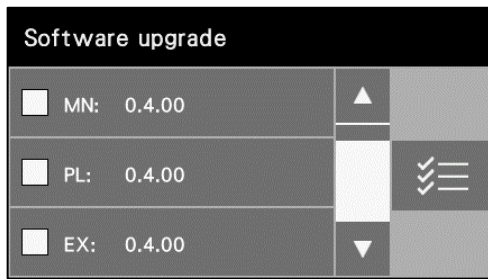

- MN: Main control program
- PL: Panel control program
- EX: Expansion control program

4. Check that the correct version number for the control program that you are going to update is displayed. If "--.--" is displayed, it is possible that the version update files have not been saved correctly into the USB media.
5. Touch the screen to place a check mark against all of the control programs that you would like to update.

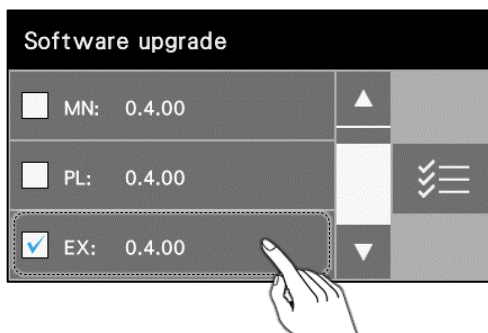

6. Touch  to display the following screen.

In the same way, place a check mark against of the control programs that you would like to update.

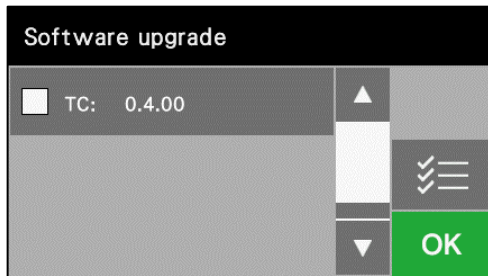

- TC:Temperature adjustment control program

7. Touch  to start the version update.

It will take from around 30 to 180 seconds for the version update to be complete. Do not turn off the power switch while the version update is in progress.

8. When the version update completion screen is displayed, turn off the power switch.

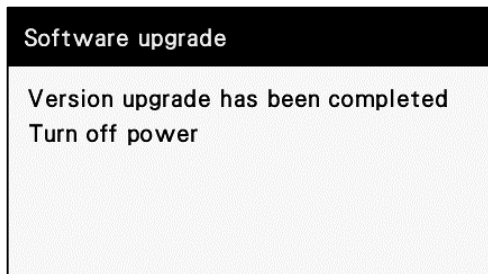

9. Remove the USB media from the USB port of the operation panel.

14 TABLE OF ERROR CODES

If a problem should occur with the bonding machine, the buzzer will sound and an error code and error message will appear in the operation panel.

Follow the remedy procedure to eliminate the cause of the problem.

Code	Cause	Remedy
E035	The treadle was still being depressed when the power was turned on.	If the treadle is being depressed, return it to the neutral position. If the treadle is not being depressed, turn off the power and check that the treadle is not being pressed.
E036	The feed speed adjustment switch is not at the neutral position when the power was turned on, or the switch is faulty.	Check that the feed speed adjustment switch is at the neutral position. If it is not at the neutral position, return it to the neutral position.
E065	An operation panel key was still being pressed when the power was turned on, or key is faulty.	Turn off the power, and then check that none of the keys on the operation panel are being pressed.
E066	The hand switch was still being pressed when the power was turned on, or switch is faulty.	Turn off the power, and then check that the hand switch is not being depressed.
E072	The feed speed adjustment switch is not at the neutral position when gluing starts.	Move the feed speed adjustment switch to the neutral position.
E081	Nozzle cap was not attached properly.	Check that the nozzle cap is attached correctly.
E085	Melter cover was not attached properly.	Check that the melter cover is attached correctly.
E090	Treadle connection is faulty.	Turn off the power, and then check that connector P8 on the main PCB is properly connected.
E091	The adjustment value for the treadle position is abnormal.	Turn off the power, and then adjust the treadle.
E200	The upper roller motor has gone out of step.	Turn off the power and check that the upper roller turns smoothly.
E210	The lower roller motor has gone out of step.	Turn off the power and check that the lower roller turns smoothly.
E220	Pump motor is out of step.	Clean the nozzle discharge holes.
E240	The upper roller pressure is outside the allowable range.	Adjust the upper roller pressure so that it is within the range set by memory switches No. 573 and No. 574 (for technicians).
E270	Nozzle clearance adjustment home position cannot be detected.	Turn off the power and check that the nozzle clearance adjustment motor is connected to connector CN20 on the expansion P. C. board.
E271	Nozzle clearance adjustment motor has stopped due to a problem.	Turn off the power and check that the lower roller arm moves smoothly.
E290	Displayed when gluing is carried out continuously for 3 minutes or more.	Turn the power off and then back on again.
E410	Communication error detected between the main PCB and the panel PCB.	Turn the power off and then back on again. If this does not solve the problem, turn off the power, and then check that connector P5 on the main P.C. board is properly inserted.
E412	Communication error detected between the main PCB and the temperature control PCB.	Turn the power off and then back on again. If this does not solve the problem, turn off the power, and then check that connector CN9 on the expansion P.C. board and connector CN14 on the temperature adjustment P. C. board are properly inserted.
E415	Communication error detected between the main P.C. board and the expansion P.C. board.	Turn the power off and then back on again. If this does not solve the problem, turn off the power, and then check that connector P23 on the main P.C. board and connector CN25 on the expansion P. C. board are properly inserted.
E420	No USB media is inserted.	Insert the USB media into the USB port of the operation panel.
E422	An error occurred while reading from USB media.	Check the files in the USB media.
E424	Not enough free space in the USB media.	Increase the amount of free space.
E425	An error occurred while writing to USB media.	Use the specified USB media.
E440	Problem with the EEPROM on the main PCB.	Turn the power off and then back on again.

Code	Cause	Remedy
E450	Model selection cannot be read from the machine head memory.	Turn off the power, and then check that connector P4 on the main P.C. board is properly connected.
E451	Data cannot be backed up to the machine head memory.	Turn the power off and then back on again.
E452	Machine head memory is not connected.	Turn off the power, and then check that connector P4 on the main P.C. board is properly connected.
E453	The data in the machine head memory (counter, home position information, etc.) cannot be read correctly.	Turn the power off and then back on again.
E601	Melter pressurization is outside the allowable range.	Adjust the melter pressurization so that it is within the value range set by memory switches No. 571 and No. 572 (for technicians).
E603	The temperature did not reach the target temperature within the specified length of time.	Turn off the power, and then check the installation of the heater.
E604	Nozzle is not lowered.	Move the nozzle to its lowest position and then start gluing.
E605	Nozzle home position cannot be detected.	If the nozzle is within its movement range, clear the error and then carry out home position detection once more. If the nozzle is outside its movement range, turn off the power, and then check that connector CN8 on the expansion P.C. board is properly connected.
E607	Nozzle home position sensor problem.	Turn off the power, and then check that connector CN8 on the expansion P.C. board is properly connected.
E610	Problem with heater (melter) OFF current.	Turn off the power, and then check the temperature fuse (melter), the heater (melter) and the leakage current breaker.
E611	Problem with heater (melter) ON current.	Turn off the power, and then check the temperature control PCB.
E612	Problem with heater (pump) OFF current.	Turn off the power, and then check the temperature fuse (pump), the heater (pump) and the leakage current breaker.
E613	Problem with heater (pump) ON current.	Turn off the power, and then check the temperature control PCB.
E614	Problem with heater (nozzle) OFF current.	Turn off the power, and then check the temperature fuse (nozzle), the heater (nozzle) and the leakage current breaker.
E615	Problem with heater (nozzle) ON current.	Turn off the power, and then check the temperature control PCB.
E620	Gluing is not possible because the melter temperature is outside its allowable range.	Check the temperature, and if it is within the allowable range, clear the error.
E621	Gluing is not possible because the pump temperature is outside its allowable range.	Check the temperature, and if it is within the allowable range, clear the error.
E622	Gluing is not possible because the nozzle temperature is outside its allowable range.	Check the temperature, and if it is within the allowable range, clear the error.
E623	Problem with temperature sensor (melter).	Turn off the power, and then check the connection between the temperature sensor (melter) and the temperature control PCB.
E624	Problem with temperature sensor (pump).	Turn off the power, and then check the connection between the temperature sensor (pump) and the temperature control PCB.
E625	Problem with temperature sensor (nozzle).	Turn off the power, and then check the connection between the temperature sensor (nozzle) and the temperature control PCB.
E630	Melter is overheating.	Turn off the power, and then check the installation of the temperature sensor (melter) to the melter and the connection to the temperature control PCB.
E631	Pump is overheating.	Turn off the power, and then check the installation of the temperature sensor (pump) to the pump unit and the connection to the temperature control PCB.

14 TABLE OF ERROR CODES

Code	Cause	Remedy
E632	Nozzle is overheating.	Turn off the power, and then check the installation of the temperature sensor (nozzle) to the nozzle lever and the connection to the temperature control PCB.
E700	Abnormal rise in power supply voltage.	Turn off the power, and then check the input voltage.
E705	Abnormal drop in power supply voltage.	Turn off the power, and then check the input voltage.
E708	Abnormal power supply voltage was detected.	Turn off the power, and then check the input voltage. If this does not solve the problem, turn off the power, and then check that connector P23 on the main P.C. board and connector CN25 on the expansion P. C. board are properly inserted.
E711	Abnormal electrical current detected for roller motor or pump motor.	Turn off the power and check that the roller motor and pump motor are not abnormal.
E730	Air pressure has dropped, or there is a problem with the regulator.	Check that the valve of the air unit is open, and then after adjusting the air pressure, clear the error. If this does not solve the problem, turn off the power, and then check that the regulator is properly connected and that connector CN17 on the expansion P. C. board is properly inserted.
E731	Abnormal rise in pump pressure.	Clean the nozzle discharge holes. If this does not solve the problem, clean the glue path.
E741	Machine head fan does not operate.	Turn off the power, and then check that the machine head fan turns smoothly and that connector CN13 on the temperature control P.C. board is properly inserted.
E900	Glue level is insufficient.	Replace the glue cartridge.
E901	The amount of glue remaining is low.	Replace the glue cartridge while taking into consideration the gluing process and the amount of glue remaining.
E905	Glue heating time has been exceeded.	Replace the glue cartridge.

If an error code that is not listed above appears or if carrying out the specified remedy does not solve the problem, contact the place of purchase.