

BAS-341JX BAS-342JX

INSTRUCTION MANUAL

Please read this manual before using the machine.
Please keep this manual within easy reach for quick reference.

DIRECT DRIVE
PROGRAMMABLE ELECTRONIC PATTERN SEWER



brother

Thank you very much for buying a BROTHER sewing machine. Before using your new machine, please read the safety instructions below and the explanations given in the instruction manual.

With industrial sewing machines, it is normal to carry out work while positioned directly in front of moving parts such as the needle and thread take-up lever, and consequently there is always a danger of injury that can be caused by these parts. Follow the instructions from training personnel and instructors regarding safe and correct operation before operating the machine so that you will know how to use it correctly.



SAFETY INSTRUCTIONS

[1] Safety indications and their meanings

This instruction manual and the indications and symbols that are used on the machine itself are provided in order to ensure safe operation of this machine and to prevent accidents and injury to yourself or other people.

The meanings of these indications and symbols are given below.

Indications

| | |
|--|---|
|  DANGER | The instructions which follow this term indicate situations where failure to follow the instructions will result in death or serious injury. |
|  WARNING | The instructions which follow this term indicate situations where failure to follow the instructions could result in death or serious injury. |
|  CAUTION | The instructions which follow this term indicate situations where failure to follow the instructions may result in minor or moderate injury. |

Symbols



..... This symbol () indicates something that you should be careful of. The picture inside the triangle indicates the nature of the caution that must be taken.
(For example, the symbol at left means "beware of injury".)



..... This symbol () indicates something that you must not do.



..... This symbol () indicates something that you must do. The picture inside the circle indicates the nature of the thing that must be done.
(For example, the symbol at left means "you must make the ground connection".)

[2] Notes on safety

DANGER



Wait at least 5 minutes after turning off the power switch and disconnecting the power cord from the wall outlet before opening the control box cover. Touching areas where high voltages are present can result in severe injury.

WARNING



Do not allow any liquids to get onto this sewing machine, otherwise fire, electric shocks or operating problems may occur.



If any liquid gets inside the sewing machine (machine head or control box), immediately turn off the power and disconnect the power plug from the electrical outlet, and then contact the place of purchase or a qualified technician.

CAUTION

Environmental requirements



Use the sewing machine in an area which is free from sources of strong electrical noise such as electrical line noise or static electric noise. Sources of strong electrical noise may cause problems with correct operation.



Any fluctuations in the power supply voltage should be within $\pm 10\%$ of the rated voltage for the machine. Voltage fluctuations which are greater than this may cause problems with correct operation.



The power supply capacity should be greater than the requirements for the sewing machine's power consumption. Insufficient power supply capacity may cause problems with correct operation.



The pneumatic delivery capability should be greater than the requirements for the sewing machine's total air consumption. Insufficient pneumatic delivery capability may cause problems with correct operation.



The ambient temperature should be within the range of 5°C to 35°C during use. Temperatures which are lower or higher than this may cause problems with correct operation.



The relative humidity should be within the range of 45% to 85% during use, and no dew formation should occur in any devices. Excessively dry or humid environments and dew formation may cause problems with correct operation.















In the event of an electrical storm, turn off the power and disconnect the power cord from the wall outlet. Lightning may cause problems with correct operation.













Do not connect anything to the USB port other than the USB memory. If this is not observed, problems with operation may result.

CAUTION



Installation

-  Machine installation should only be carried out by a qualified technician.
-  Contact your Brother dealer or a qualified electrician for any electrical work that may need to be done.
-  The sewing machine weighs approximately 170 kg. Use equipment such as a crane or hoist when installing the machine head and adjusting the height of the table.
If you try to lift the machine head yourself, it may cause injuries such as back injury.
-  Do not connect the power cord until installation is complete. If the foot switch is depressed by mistake, the sewing machine might start operating and injury could result.
-  Hold the machine head with both hands when tilting it back or returning it to its original position.
In addition, do not subject the machine head to extra force while it is tilted back. If this is not observed, the machine head may become unbalanced and fall down, and serious injury or damage to the sewing machine may result.
-  Be sure to connect the ground. If the ground connection is not secure, you run a high risk of receiving a serious electric shock, and problems with correct operation may also occur.
-  All cords should be secured at least 25 mm away from any moving parts. Furthermore, do not excessively bend the cords or secure them too firmly with staples, otherwise there is the danger that fire or electric shocks could occur.
- 
-  Install the safety covers to the machine head and motor.
-  If using a work table which has casters, the casters should be secured in such a way so that they cannot move.
-  Use a table with a height of 84 cm or less. If the table is too high, the machine head may become unbalanced and fall down, and serious injury or damage to the sewing machine may result.
-  Be sure to wear protective goggles and gloves when handling the lubricating oil and grease, so that they do not get into your eyes or onto your skin. If the oil and grease get into your eyes or onto your skin, inflammation can result.
Furthermore, do not drink or eat the lubricating oil or grease. They may cause diarrhea or vomiting. Keep the oil out of the reach of children.
-  Be careful to avoid injury from moving parts.

Sewing

-  To prevent problems, do not use objects with sharp points to operate the LCD panel.
-  This sewing machine should only be used by operators who have received the necessary training in safe use beforehand.
-  The sewing machine should not be used for any applications other than sewing.
-  Be sure to wear protective goggles when using the machine.
If goggles are not worn, there is the danger that if a needle breaks, parts of the broken needle may enter your eyes and injury may result.
-  Turn off the power switch at the following times. If the foot switch is depressed by mistake, the sewing machine might start operating and injury could result.
 - When replacing the bobbin and needle
 - When not using the machine and when leaving the machine unattended
-  If using a work table which has casters, the casters should be secured in such a way so that they cannot move.
-  Attach all safety devices before using the sewing machine. If the machine is used without these devices attached, injury may result.
-  Do not touch any of the moving parts or press any objects against the machine while sewing, as this may result in personal injury or damage to the machine.
-  If an error occurs in machine operation, or if abnormal noises or smells are noticed, immediately turn off the power switch. Then contact your nearest Brother dealer or a qualified technician.
-  If the machine develops a problem, contact your nearest Brother dealer or a qualified technician.

Cleaning

-  Turn off the power switch before carrying out cleaning. If the foot switch is depressed by mistake, the sewing machine might start operating and injury could result.
-  Be sure to wear protective goggles and gloves when handling the lubricating oil and grease, so that they do not get into your eyes or onto your skin. If the oil and grease get into your eyes or onto your skin, inflammation can result.
Furthermore, do not drink or eat the lubricating oil or grease. They may cause diarrhea or vomiting. Keep the oil out of the reach of children.

CAUTION

Maintenance and inspection



Maintenance and inspection of the sewing machine should only be carried out by a qualified technician.



Ask your Brother dealer or a qualified electrician to carry out any maintenance and inspection of the electrical system.



Turn off the power switch and disconnect the power cord before carrying out the following operations. If the foot switch is depressed by mistake, the sewing machine might start operating and injury could result.

- Inspection, adjustment and maintenance
- Replacing consumable parts such as the rotary hook



Disconnect the air hoses from the air supply and wait for the needle on the pressure gauge to drop to "0" before carrying out inspection, adjustment and repair of any parts which use the pneumatic equipment.



Hold the machine head with both hands when tilting it back or returning it to its original position.

In addition, do not subject the machine head to extra force while it is tilted back. If this is not observed, the machine head may become unbalanced and fall down, and serious injury or damage to the sewing machine may result.



If the power switch needs to be left on when carrying out some adjustment, be extremely careful to observe all safety precautions.



When replacing parts and installing optional accessories, be sure to use only genuine Brother parts.

Brother will not be held responsible for any accidents or problems resulting from the use of non-genuine parts.



If any safety devices have been removed, be absolutely sure to re-install them to their original positions and check that they operate correctly before using the machine.



To prevent accidents and problems, do not modify the machine yourself.

Brother will not be held responsible for any accidents or problems resulting from modifications made to the machine.

[3] Warning labels

The following warning labels appear on the sewing machine.
Please follow the instructions on the labels at all times when using the machine. If the labels have been removed or are difficult to read, please contact your nearest Brother dealer.

| | | | |
|---|---|--|---|
| 1 | | ⚠ 危険 高電圧部分にふれて、大けがをすることがある。 電源を切り、5分たってからカバーをはずすこと。 | ⚠ 危険 触摸高压电部分, 会导致受伤。 在切断电源5分钟后, 再开启盖罩。 |
| | ⚠ DANGER | ⚠ GEFAHR | ⚠ DANGER |
| | Hazardous voltage will cause injury. Turn off main switch and wait 5 minutes before opening this cover. | Hochspannung verletzungsgefahr! Bitte schalten sie den hauptschalter aus und warten sie 5 minuten, bevor sie diese abdeckung öffnen. | Un voltage non adapte provoque des blessures. Eteindre l'interrupteur et attendre 5 minutes avant d'ouvrir le capot. |
| | | ⚠ PELIGRO | Un voltaje inadecuado puede provocar las heridas. Apagar el interruptor principal y esperar 5 minutos antes de abrir esta cubierta. |

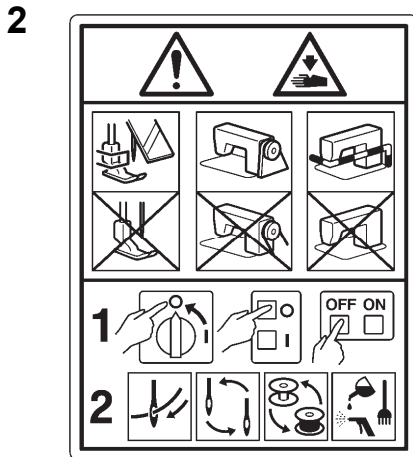

CAUTION
Moving parts may cause injury.

Operate with safety devices* installed.

Turn off the power before carrying out operations such as threading, changing the needle, bobbin, knives or hook, cleaning and adjusting.

*Safety devices

Devices such as eye guard, finger guard, thread take-up cover, motor cover, X motor cover, rear cover, solenoid cover, inner cover, outer cover, fixed cover and gas spring support cover

3 Be careful to avoid injury from moving parts.

4 PE Be sure to connect the ground.
If the ground connection is not secure, you run a high risk of receiving a serious electric shock, and problems with correct operation may also occur.

5 Direction of operation

6 Be careful not to get your hand caught when tilting back the machine head and returning it to its original position.

8 High temperature warning display

7 **brother**
Lubricating Oil for Machining
ミシン用潤滑油

⚠ CAUTION

Lubricating oil may cause inflammation to eye and skin.
Wear protective glasses and gloves.

Swallowing oil can cause diarrhoea and vomiting.
Do not swallow.

Keep away from children.
FIRST AID

Eye contact:
-Rinse with plenty of cold water.
-Seek medical help.

Skin contact:
-Wash with soap and water.

If swallowed:
-Seek medical help immediately.
-Do not induce vomiting.

⚠ 注意

目に入ったり皮膚につくと、炎症を起こすことがある。保護メガネ、手袋を使うこと。

飲み込むと、下痢、嘔吐する。飲み込まないこと。

- 子供の手の届かない所に置いてください。
- 目に入った場合は、清浄な水で15分間洗浄し、医師の診断を受けてください。
- 皮膚に触れた場合は、水と石けんで十分に洗ってください。
- 飲み込んだ場合は、無理に吐かせずに、直ちに医師の診断を受けてください。

**第4類 第3石油類
危険等級III 火気厳禁**

ブラザー工業株式会社
〒448-0803
愛知県刈谷市野田町北地蔵山1番地5
電話：0566-95-0085

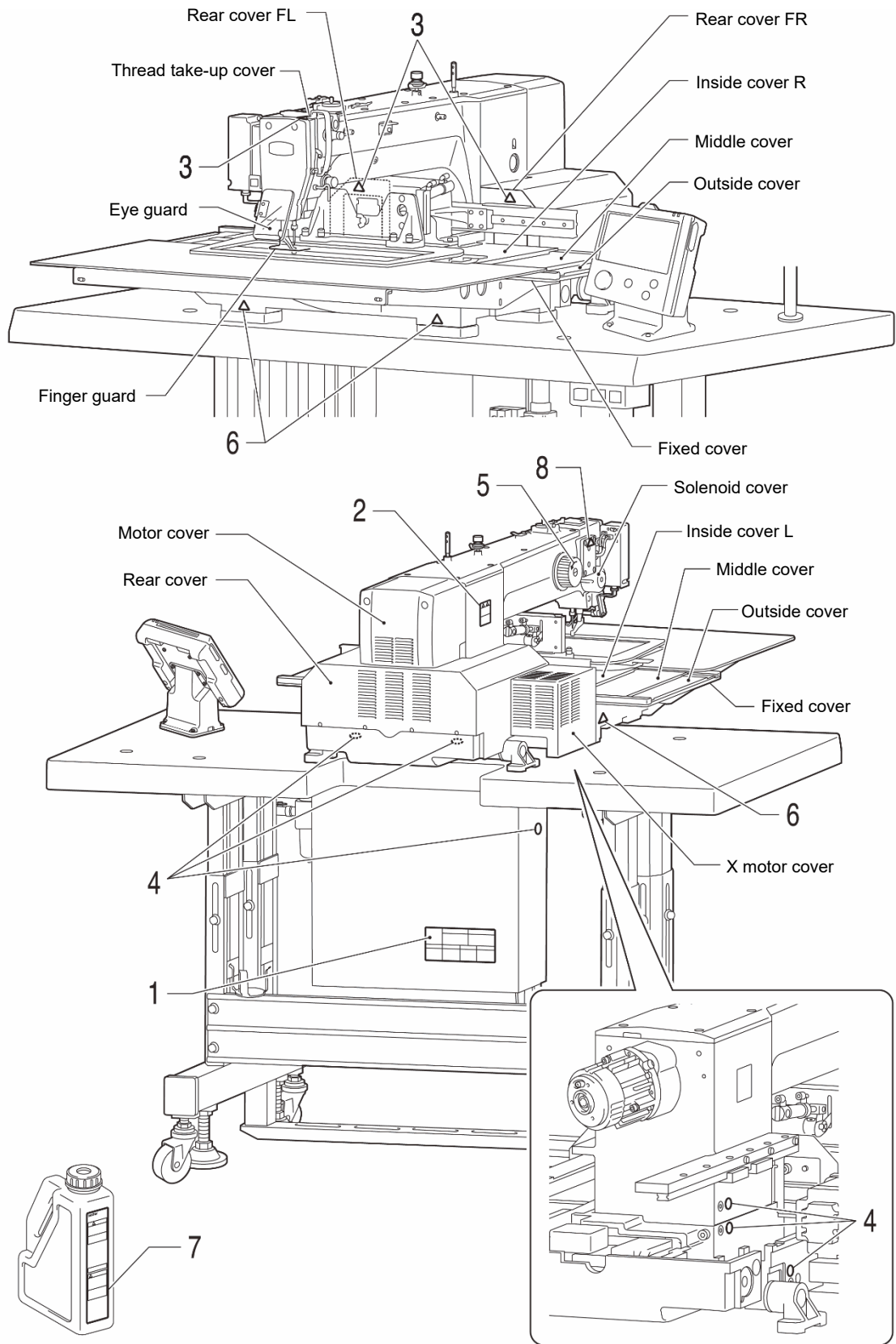

4587B

CONTENTS

| | |
|---|-----------|
| 1. NAMES OF MAJOR PARTS | 1 |
| 2. SPECIFICATIONS | 2 |
| 3. INSTALLATION | 3 |
| 3-1. Table processing diagram | 4 |
| 3-2. Installing the control box..... | 5 |
| 3-3. Installing the oil pan and support lever base | 6 |
| 3-4. Installing the machine head..... | 6 |
| 3-5. Tilting back and returning the machine head ... | 7 |
| 3-6. Installing the gas spring | 8 |
| 3-7. Installing the solenoid valve assembly | 9 |
| 3-8. Connecting the air tubes..... | 9 |
| 3-9. Installing the air hose..... | 9 |
| 3-10. Installing the two-pedal foot switch..... | 10 |
| 3-11. Installing the hand switch (Option devices) | 10 |
| 3-12. Installing the LCD panel | 11 |
| 3-13. Installing the cords..... | 11 |
| 3-14. Connecting the ground wire..... | 16 |
| 3-15. Securing the cords and air tubes..... | 17 |
| 3-16. Connecting the power cord..... | 18 |
| 3-17. Installing the eye guard | 20 |
| 3-18. Installing the cotton stand..... | 20 |
| 3-19. Lubrication | 21 |
| 3-20. Checking the machine head switch..... | 22 |
| 4.PREPARATION BEFORE SEWING..... | 23 |
| 4-1. Installing the needle..... | 23 |
| 4-2. Start switch operation method | 23 |
| 4-3. Threading the upper thread | 24 |
| 4-4. Winding the lower thread..... | 26 |
| 4-5. Installing the bobbin case | 27 |
| 4-6. Thread tension..... | 28 |
| 4-6-1. Lower thread tension | 28 |
| 4-6-2. Upper thread tension | 29 |
| 4-7. Starting up | 30 |
| 4-8. LED light operation method..... | 31 |
| 5. SEWING..... | 32 |
| 5-1. Sewing | 32 |
| 5-2. Using the STOP switch..... | 33 |
| 6. CLEANING | 34 |
| 6-1. Cleaning the rotary hook | 34 |
| 6-2. Draining the oil..... | 34 |
| 6-3. Cleaning the regulator | 35 |
| 6-4. Checking the control box air inlet ports | 35 |
| 6-5. Cleaning the eye guard | 35 |
| 6-6. Checking the needle | 35 |
| 6-7. Cleaning around the needle plate and rotary hook..... | 36 |
| 6-8. Lubrication..... | 36 |
| 6-9. Applying grease | 37 |
| 7.STANDARD ADJUSTMENTS | 40 |
| 7-1. Thread take-up spring | 41 |
| 7-2. Adjusting the skipped stitch and thread breakage detector position | 41 |
| 7-3. Adjusting the needle bar height | 42 |
| 7-4. Adjusting the needle and rotary hook timing..... | 42 |
| 7-5. Adjusting the driver (needle guard) position | 43 |
| 7-6. Adjusting the clearance between the needle and rotary hook tip..... | 43 |
| 7-7. Adjusting the shuttle race thread guide | 43 |
| 7-8. Rotary hook lubrication amount | 44 |
| 7-9. Adjusting the thread trimming home position at the sewing end | 45 |
| 7-11. Replacing the movable and fixed knives | 48 |
| 7-12. Feed plate installation method | 49 |
| 7-13. Adjusting the thread wiper | 50 |
| 7-14. Intermittent presser foot installation position | 50 |
| 7-15. Adjusting the work clamp lift amount | 51 |
| 7-16. Adjusting the air pressure | 51 |
| 7-17. Adjusting the speed controller..... | 52 |
| 7-18. If processing the work clamp to a shape that matches the sewing pattern | 53 |
| 8. LIST OF ERROR CODES..... | 56 |
| 9. TROUBLESHOOTING..... | 62 |

1. NAMES OF MAJOR PARTS

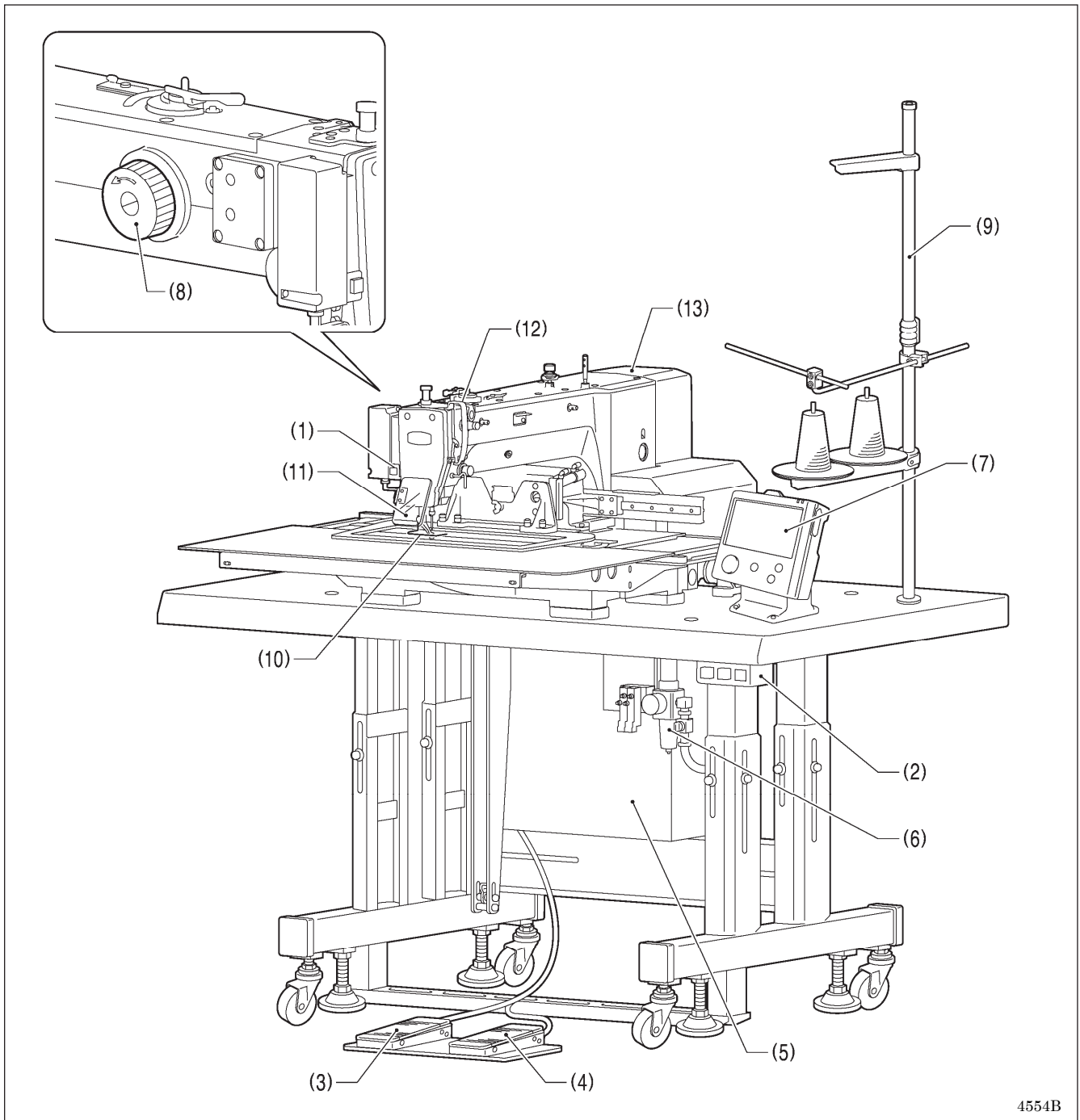

4554B

- (1) STOP switch
- (2) Power switch
- (3) Work clamp switch
- (4) Start switch
- (5) Control box
- (6) Solenoid valve
- (7) LCD panel
- (8) Pulley
- (9) Cotton stand

- Safety devices:**
- (10) Finger guard
 - (11) Eye guard
 - (12) Thread take-up cover
 - (13) Motor cover

2. SPECIFICATIONS

| Specifications | BAS341JX-0AA | BAS342JX-0AA |
|---|--|--------------|
| Application | Air bags | |
| Sewing machine | Lock stitch pattern tacking sewing machine | |
| Stitch formation | Single needle lock stitch | |
| Max. sewing speed | 2,800 sti/min | |
| Max. sewing area (X x Y) | 250 x 160 mm | 300 x 200 mm |
| Feed mechanism | Intermittent feed, pulse motor drive | |
| Stitch length | 0.05 – 20 mm | |
| Maximum No. of stitches | 20,000 stitches (per program) | |
| No. of sewing data items that can be stored | 999 (Internal memory, SD card, USB memory) (*1) | |
| Work clamp lift method | Pneumatic cylinder method | |
| Work clamp height | Max. 30 mm | |
| work clamp | Integrated-type | |
| Intermittent presser foot lift amount | 27 mm (During reverse needle lifting) | |
| Intermittent presser foot stroke | 0 – 10 mm (per 0.1 mm) | |
| Hook | Double-capacity shuttle hook | |
| Wiper device | Standard equipment | |
| Thread trimmer | Standard equipment | |
| Digital tension | Standard equipment | |
| Bobbin winder | Standard equipment | |
| Skipped stitch and thread breakage detector | Standard equipment | |
| LED light | Standard equipment (6-step brightness adjustment) | |
| Material thickness detection function | Standard equipment | |
| Start switch | 2-pedal foot switch | |
| Cycle programs | 30 | |
| Motor | 550 W AC servo motor | |
| Weights | Machine head: 170 kg | |
| | Control box: 18 kg | |
| Control box power supply voltage (*2) | Single-phase 220V-240V, 3-phase 200V-220V, Power consumption 450 VA | |
| Air pressure | 0.5 MPa 1.8 l/min. | |













(*1) The number of data items and stitches that can be stored will vary depending on the number of stitches in each program.

No guarantees of operation can be given for any media.

(*2) If using a power supply voltage which is outside the normal specifications, contact the place of purchase.

3. INSTALLATION

CAUTION

-  Machine installation should only be carried out by a qualified technician.
-  Contact your Brother dealer or a qualified electrician for any electrical work that may need to be done.
-  The sewing machine head weighs approximately 170 kg. Use equipment such as a crane or hoist when installing the machine head and adjusting the height of the table. If you try to lift the machine head yourself, it may cause injuries such as back injury.
-  Do not connect the power cord until installation is complete. If the foot switch is depressed by mistake, the sewing machine might start operating and injury could result.
-  If using a work table which has casters, the casters should be secured in such a way so that they cannot move.
-  Use a table with a height of 84 cm or less. If the table is too high, the machine head may become unbalanced and fall down, and serious injury or damage to the sewing machine may result.
-  Hold the machine head with both hands when tilting it back or returning it to its original position. In addition, do not subject the machine head to extra force while it is tilted back. If this is not observed, the machine head may become unbalanced and fall down, and serious injury or damage to the sewing machine may result.
-  All cords should be secured at least 25 mm away from any moving parts. Furthermore, do not excessively bend the cords or secure them too firmly staples, otherwise there is the danger that fire or electric shocks could occur.
-   otherwise there is the danger that fire or electric shocks could occur.
-  Be sure to connect the ground. If the ground connection is not secure, you run a high risk of receiving a serious electric shock, and problems with correct operation may also occur.
-  Install the safety covers to the machine head and motor.

3-1. Table processing diagram

- The thickness of the table should be at least 50 mm, and it should be strong enough to bear the weight and vibration of the sewing machine.
- If using casters, use ones which can bear the total weight of sewing machine and table.
- Check that the control box is at least 10 mm away from the leg. If the control box and the leg are too close together, it may result in incorrect sewing machine operation.

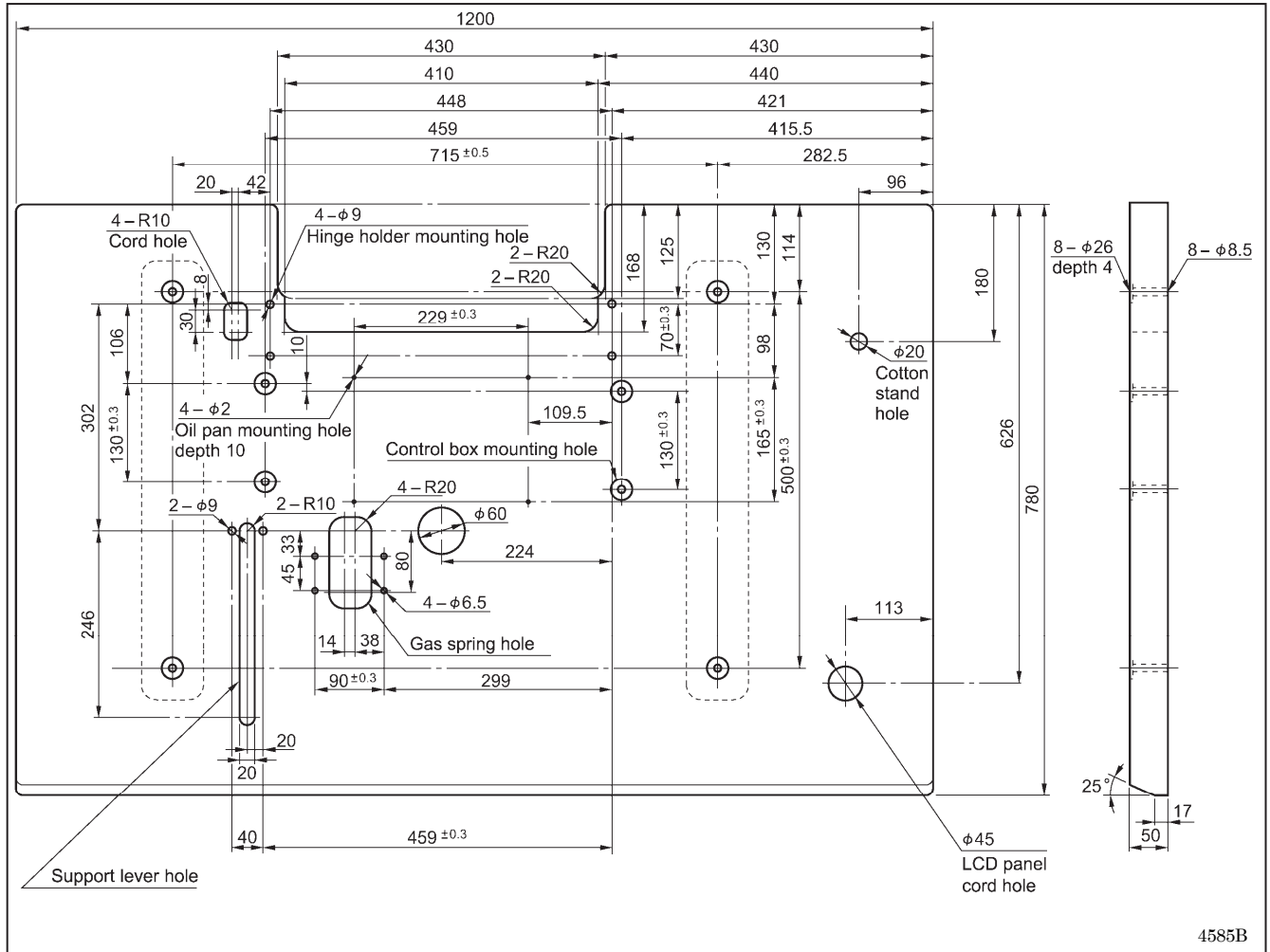

4585B

3-2. Installing the control box

! CAUTION



The control box is heavy, so installation should be carried out by two or more people. In addition, take steps to make sure that the control box does not fall down. If this is not done, injury to feet or damage to the control box may result.

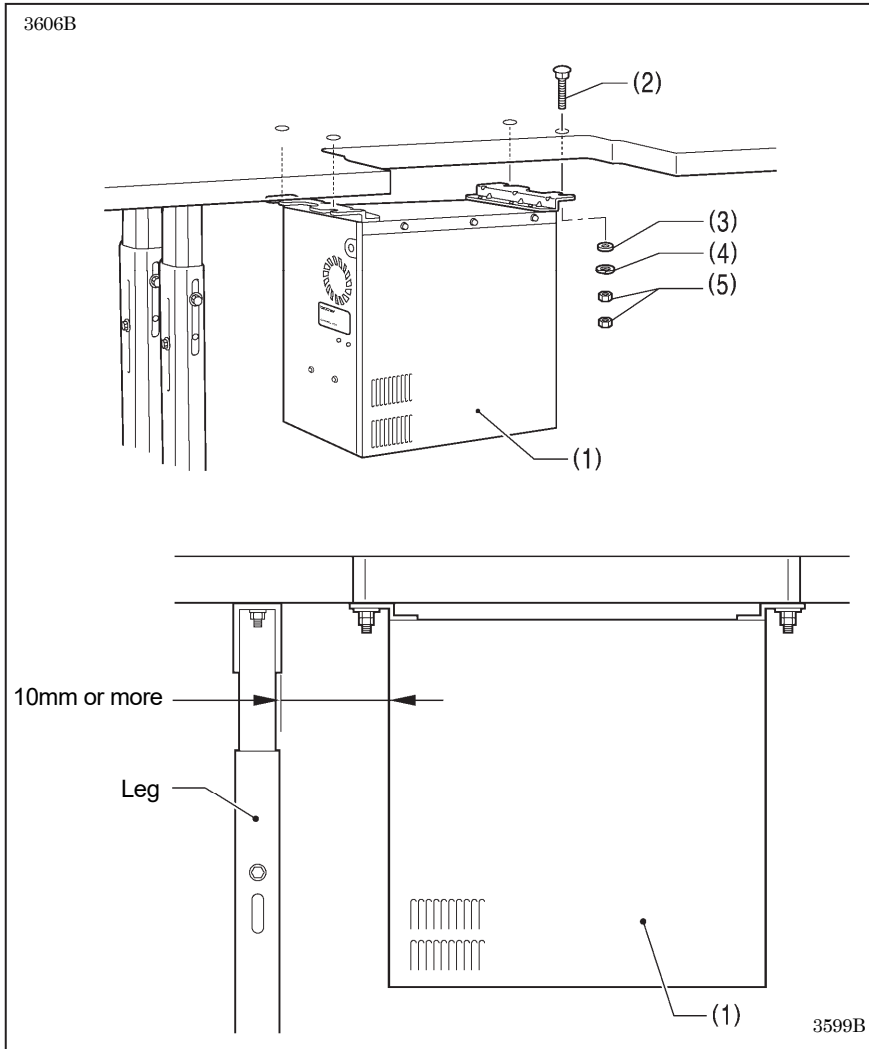

- (1) Control box
- (2) Bolts [4 pcs.]
- (3) Plain washers [4 pcs.]
- (4) Spring washers [4 pcs.]
- (5) Nuts [8 pcs.]

NOTE:

Check that the control box (1) is at least 10 mm away from the leg. If the control box (1) and the leg are too close together, it may result in incorrect sewing machine operation.

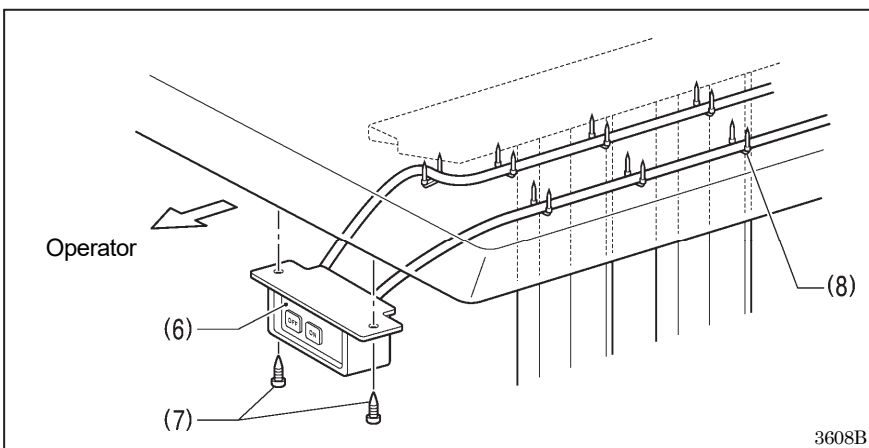

- (6) Power switch
- (7) Wood screws [2 pcs.]
- (8) Staples [7 pcs.]

NOTE:

Take care when tapping in the staples (8) to make sure that they do not pierce the power cord.

3-3. Installing the oil pan and support lever base

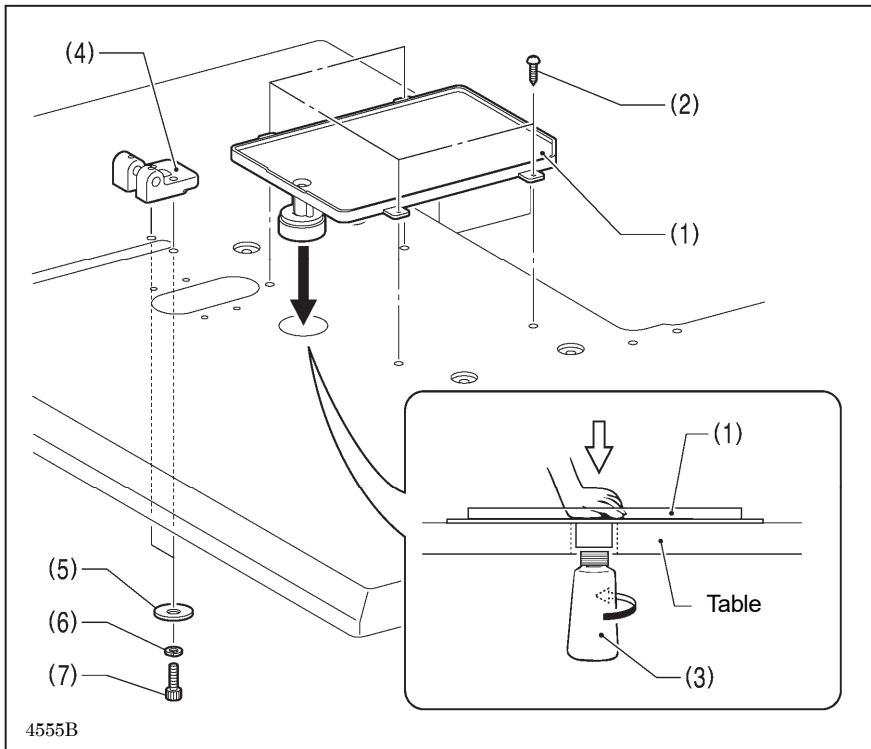

- (1) Oil pan
- (2) Wood screws [4 pcs.]
- (3) Oiler
- (4) Support lever base
- (5) Plain washers [2 pcs.]
- (6) Spring washers [2 pcs.]
- (7) Bolts [2 pcs.]

3-4. Installing the machine head

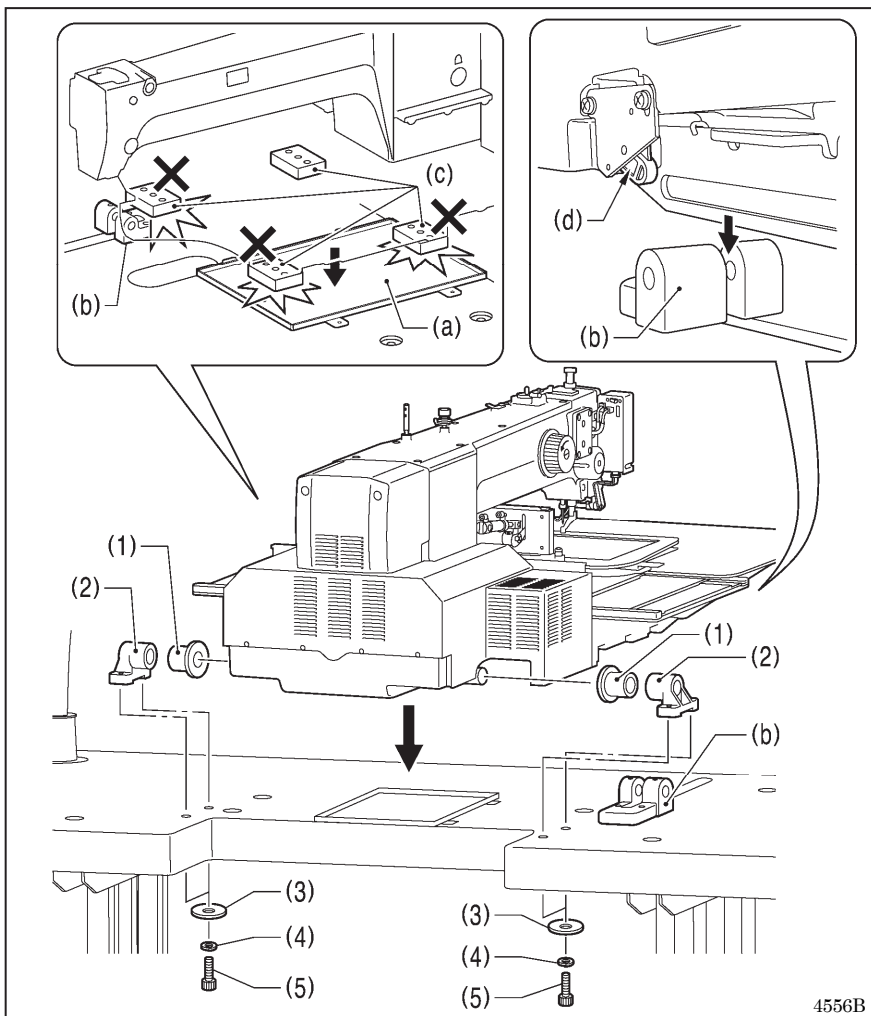

1. Place the machine head onto the table.

NOTE:

- Use a crane or hoist to install the sewing machine.
- Be careful of the following when lowering the machine head onto the table.
 - ! Do not let any cords get clamped between the machine head and the table.
 - ! Do not place the machine head cushion (c) on top of the oil pan (a) or the support lever base (b).
 - ! Do not let the side (d) of the machine head switch lever touch the support lever base (b).

- (1) Rubber bushes [2 pcs.]
- (2) Hinge holders [2 pcs.]
- (3) Plain washers [4 pcs.]
- (4) Spring washers [4 pcs.]
- (5) Bolts [4 pcs.]

(Continued on next page)

3. INSTALLATION

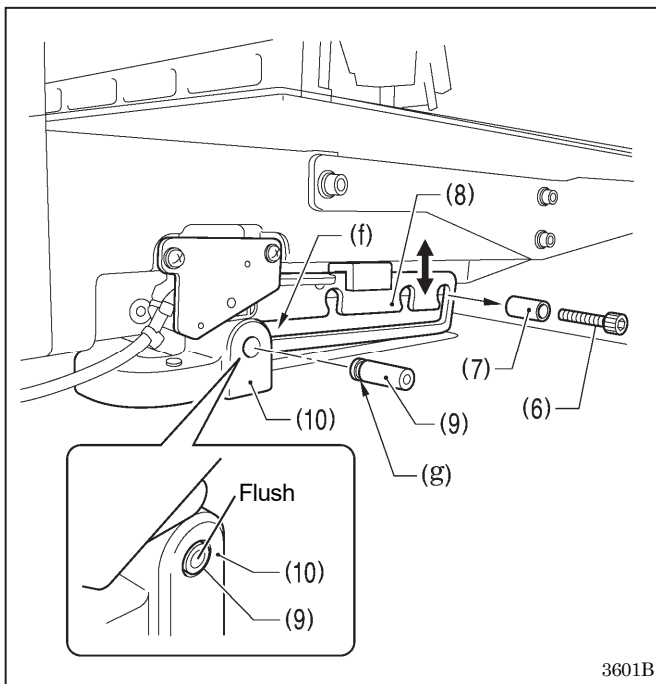

2. After placing the machine head onto the table, remove the bolt (6) and the spacer (7).

* The bolt (6) and the spacer (7) are necessary for securing the support lever (8) when the machine head is removed from the table, so keep them in a safe place.

3. Pass the support lever shaft (9) through the hole in the support lever base (10) and through the groove (f) in the support lever (8), and push it in until it is flush with the surface of the support lever base (10).

* Be sure to insert so that the groove (g) in the support lever shaft (9) faces in the direction shown in the illustration.

* If it is difficult to pass the support lever shaft (9) through the groove (f) in the support lever (8), move the end of the support lever (8) up and down while passing the support lever shaft (9) through.

3-5. Tilting back and returning the machine head

CAUTION



Hold the machine head with both hands when tilting it back or returning it to its original position. In addition, do not subject the machine head to extra force while it is tilted back. If this is not observed, the machine head may become unbalanced and fall down, and serious injury or damage to the sewing machine may result.



Always be sure to engage the stopper of the support lever (1) when tilting back the machine head. If the stopper is not engaged, the machine head may return to its original position and your hands may get caught and injury may result.



When disengaging the stopper, hold it by the knob (a). If you hold at the place indicated by (b), your hand will get caught between the support lever (1) and the table when the machine head is returned to its original position and injury will result.

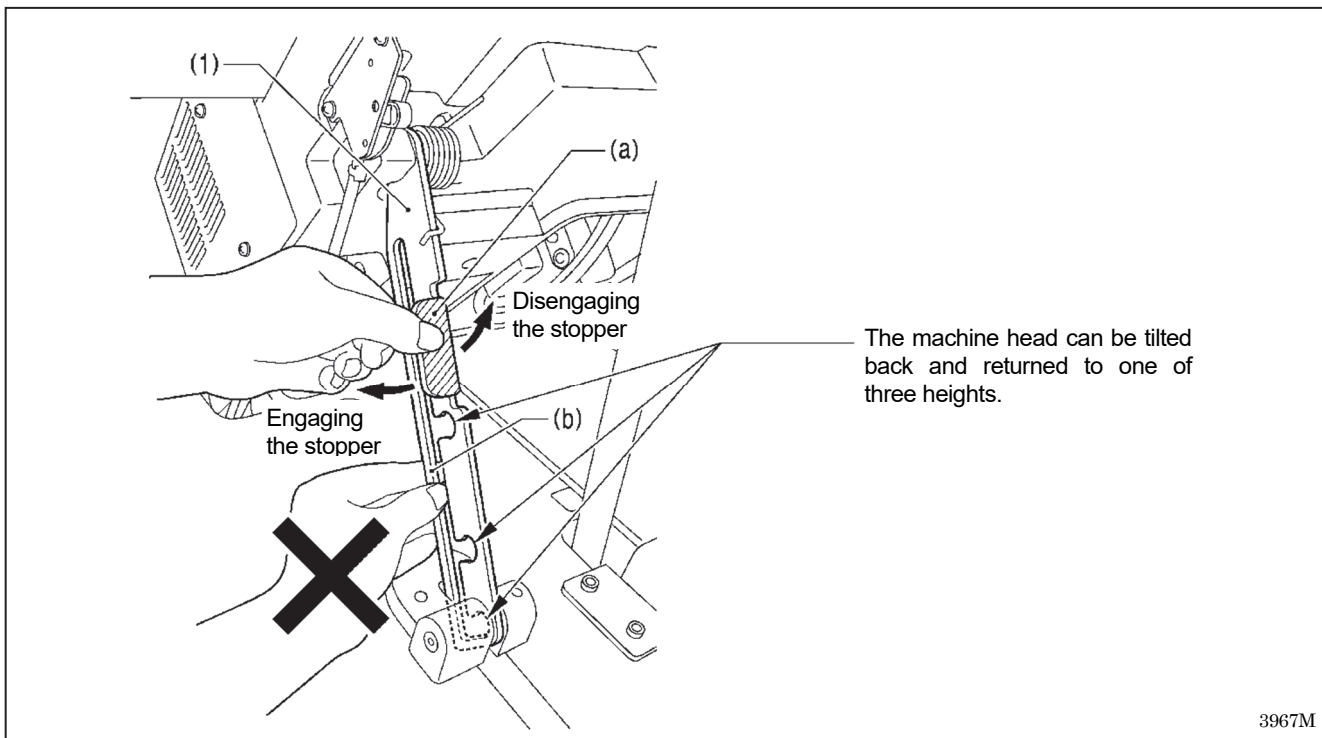

3-6. Installing the gas spring

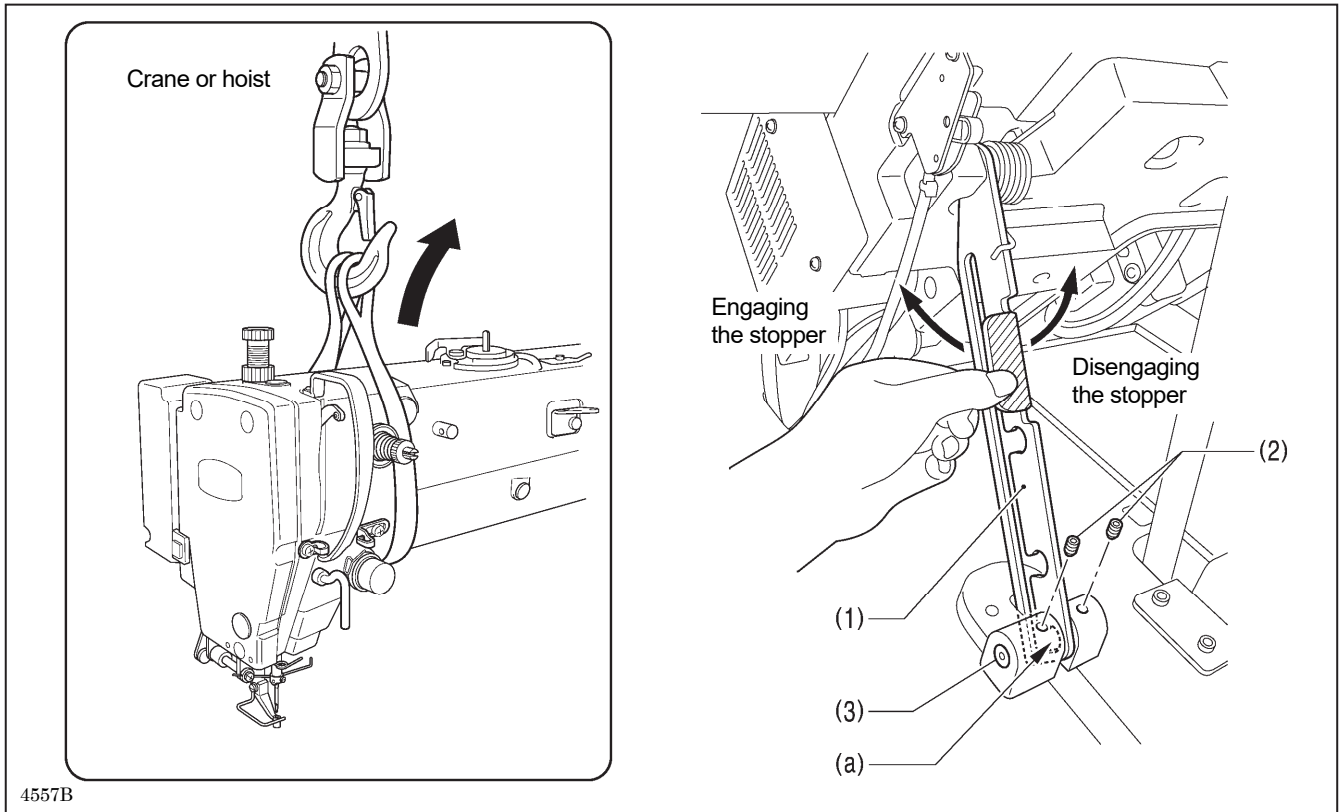

4557B

1. Tilt back the machine head, and then secure the support lever (1) at stopper position (a). (Refer to "3-5. Tilting back and returning the machine head".)

NOTE: Use equipment such as a crane or hoist to tilt back the machine head.

2. Tighten the two set screws (2) to secure the support lever shaft (3).

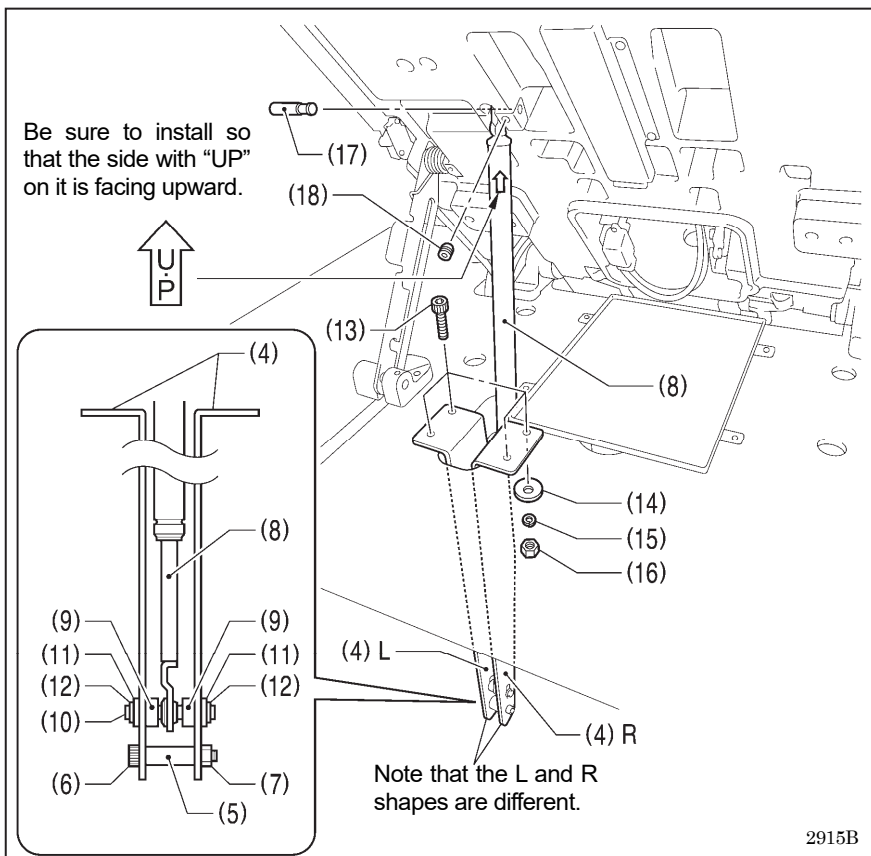

3. Install the gas spring (8).
 - (4) Gas spring holders [L and R]
 - (5) Spacer
 - (6) Bolt
 - (7) Nut
 - (8) Gas spring
 - (9) Shaft collars [2 pcs.]
 - (10) Gas spring shaft D
 - (11) Plain washers [2 pcs.]
 - (12) Retaining rings E [2 pcs.]
 - (13) Bolts [4 pcs.]
 - (14) Plain washers [4 pcs.]
 - (15) Spring washers [4 pcs.]
 - (16) Nuts [4 pcs.]
 - (17) Gas spring shaft U
 - (18) Set screw

* After installing the gas spring (8), gently return the machine head to its original position. (Refer to "3-5. Tilting back and returning the machine head".)

3-7. Installing the solenoid valve assembly

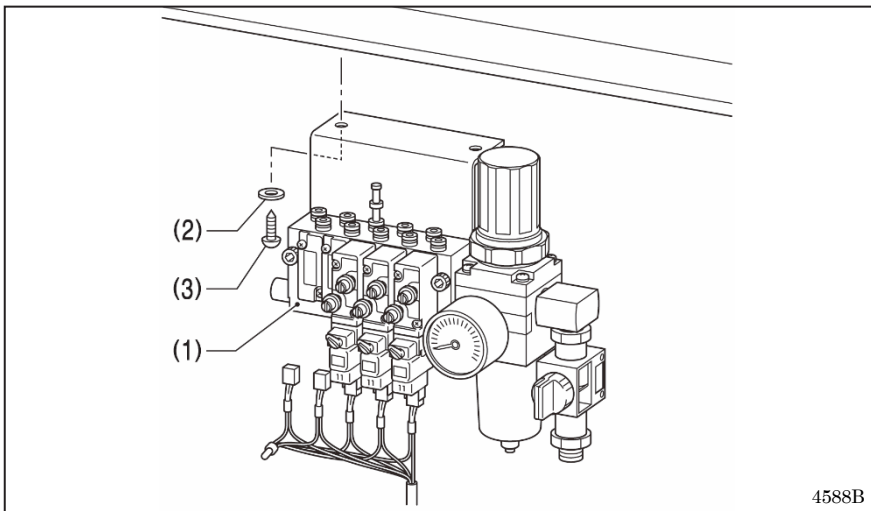

Install underneath the work table.

- (1) Solenoid valve assembly
- (2) Washers [2 pcs.]
- (3) Wood screws [2 pcs.]

NOTE:

Make sure that the solenoid valve assembly does not touch the control box or the leg of the table.

3-8. Connecting the air tubes

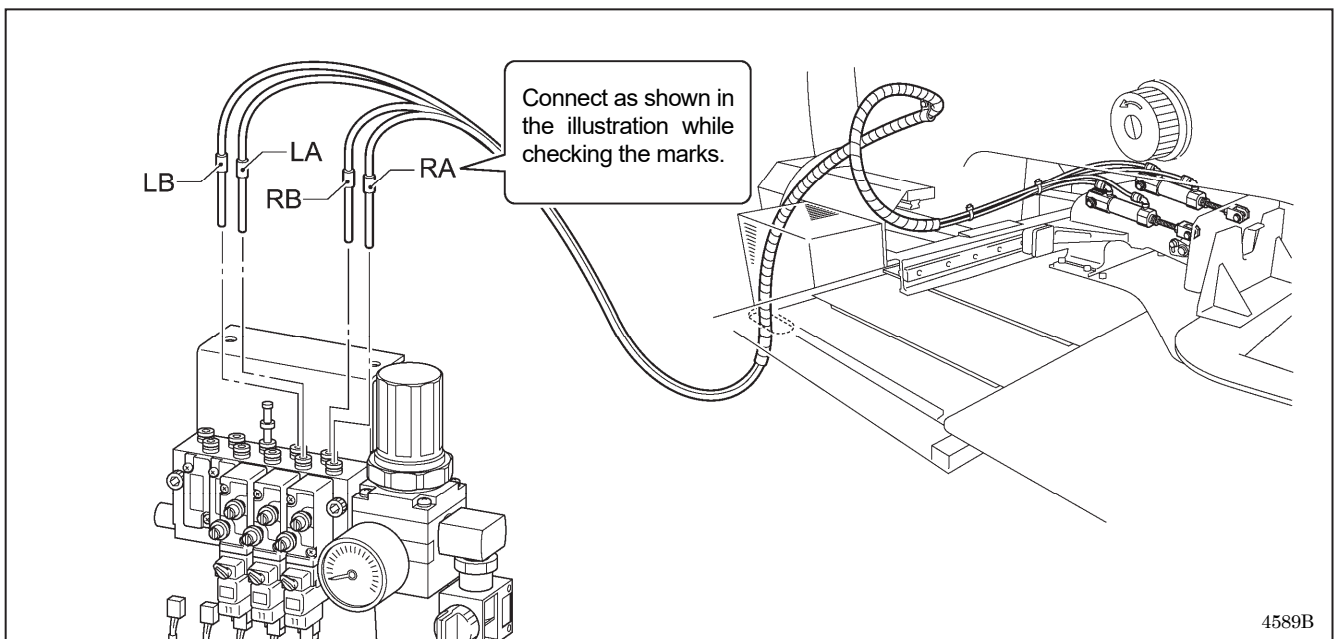

3-9. Installing the air hose

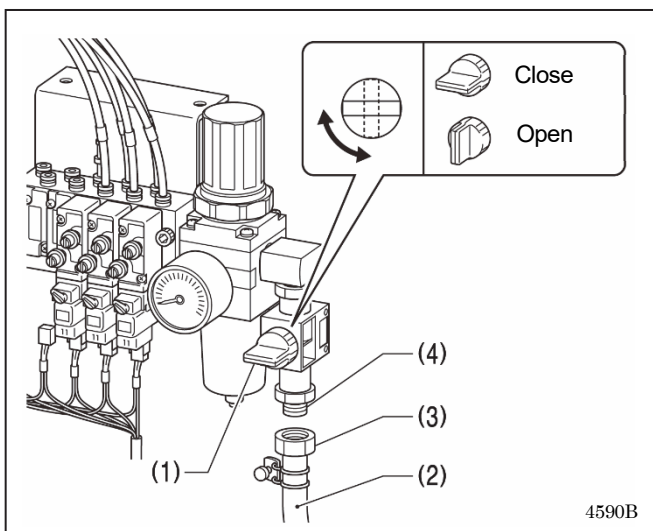

1. Close the cock (1).
2. Turn the nut (3) at the end of the air hose (2) and connect it to the valve (4).
3. Open the cock at the compressor.
* Check that no air is leaking from the connection of the valve (4) and air hose (2).
4. Open the cock (1).
(The meter pointer will turn clockwise.)

NOTE:

Turn the cock (1) gently to open it.

5. Adjust the air pressure. (Refer to "7-15. Adjusting the speed controller".)

3-10. Installing the two-pedal foot switch

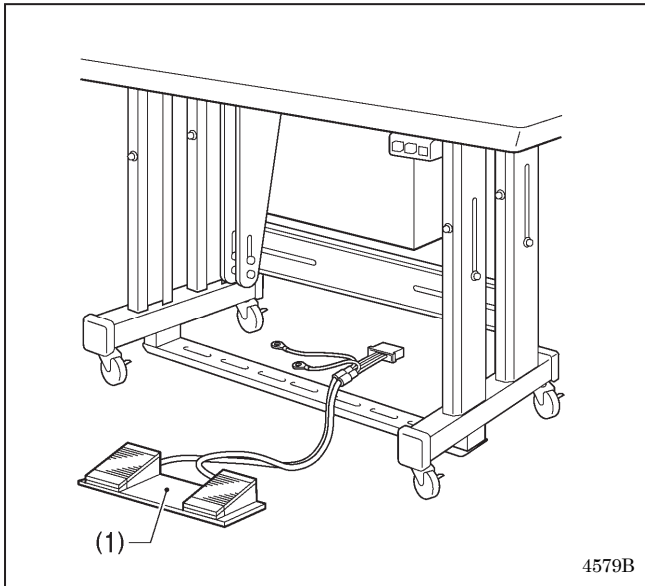

(1) Two-pedal foot switch

Connect the connector for the two-pedal foot switch (1) into the P15 (PEDAL) connector on the main P.C. board. (Refer to "3-13. Connecting the cords".)

* Be sure to make the ground connection. (Refer to "3-14. Connecting the ground wire".)

3-11. Installing the hand switch (Option devices)

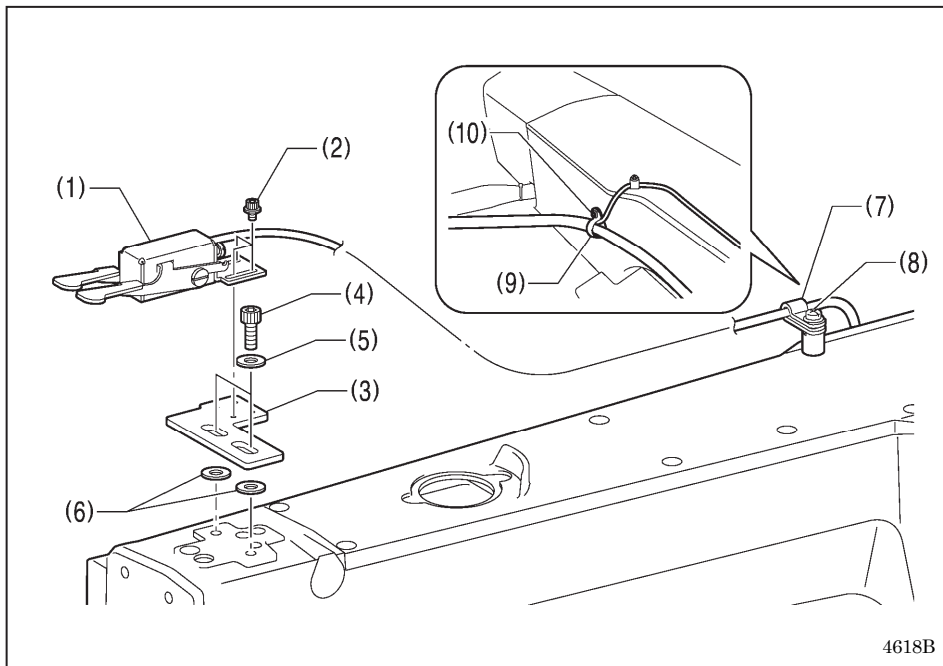

- (1) Hand switch
- (2) Socket bolts [3 pcs.]
- (3) Setting plate
- (4) Socket bolts [2 pcs.]
- (5) Washer
- (6) Washer
- (7) Cord holder S
- (8) Screw
- (9) Cord holder L
- (10) Screw

3-12. Installing the LCD panel

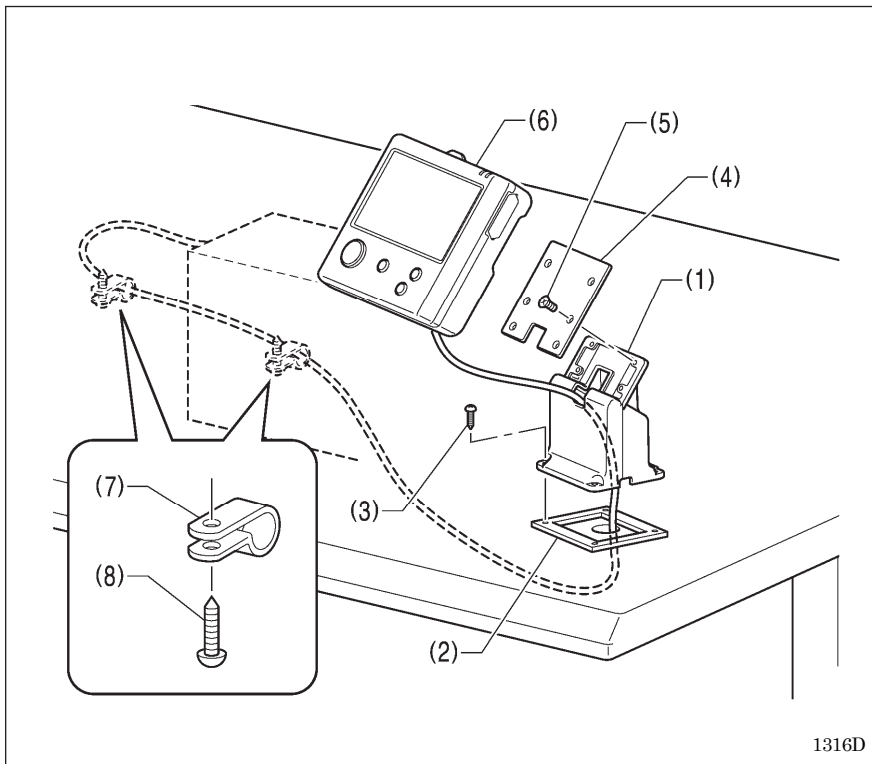

- (1) Cradle
- (2) Rubber cushion
- (3) Wood screws [4 pcs.]
- (4) Setting plate
- (5) Flat screws [4 pcs.]
- (6) LCD panel
- (7) Cord clamps [2 pcs.]
- (8) Wood screws [2 pcs.]

- Pass the cord of the LCD panel through the table hole, and then pull it into the box together with the harness from the machine head.
- Tighten the four wood screws (3) so that the thickness of the rubber cushion (2) is 5 mm.

1316D

3-13. Connecting the cords

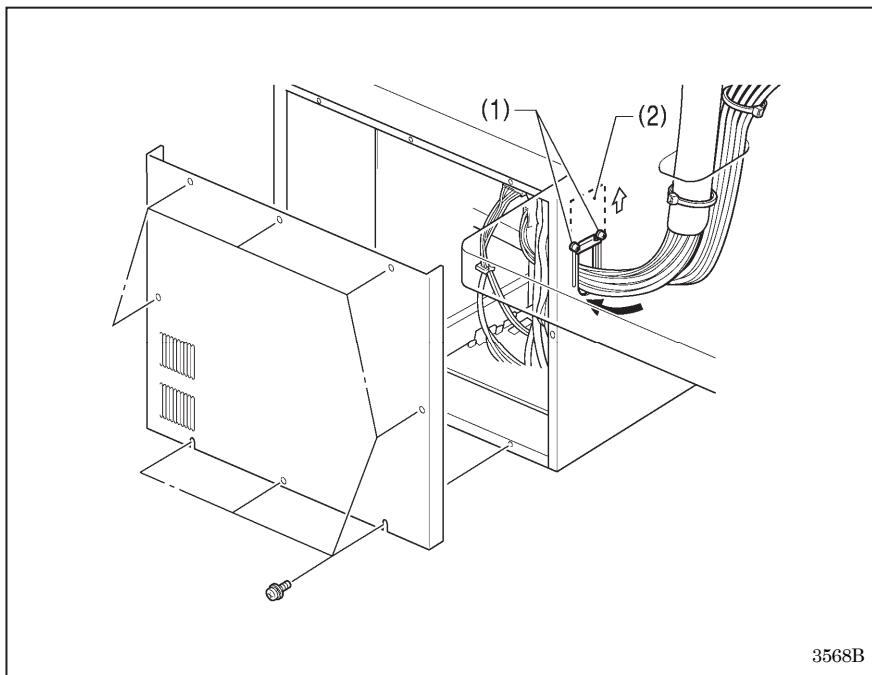

1. Remove the cover of the control box.
2. Loosen the two screws (1), and then open the cord presser plate (2) in the direction of the arrow.
3. Pass the bundle of cords from the machine head through the hole in the table, and then pass it through the hole in the control box together with the solenoid valve.
4. Securely connect the connectors as indicated in the table.
(Refer to next page)

NOTE:

- Check that the connector is facing the correct way, and then insert it firmly until it locks into place.
- Secure the cables with cable ties and cord clamps, while being careful not to pull on the connector.

3568B

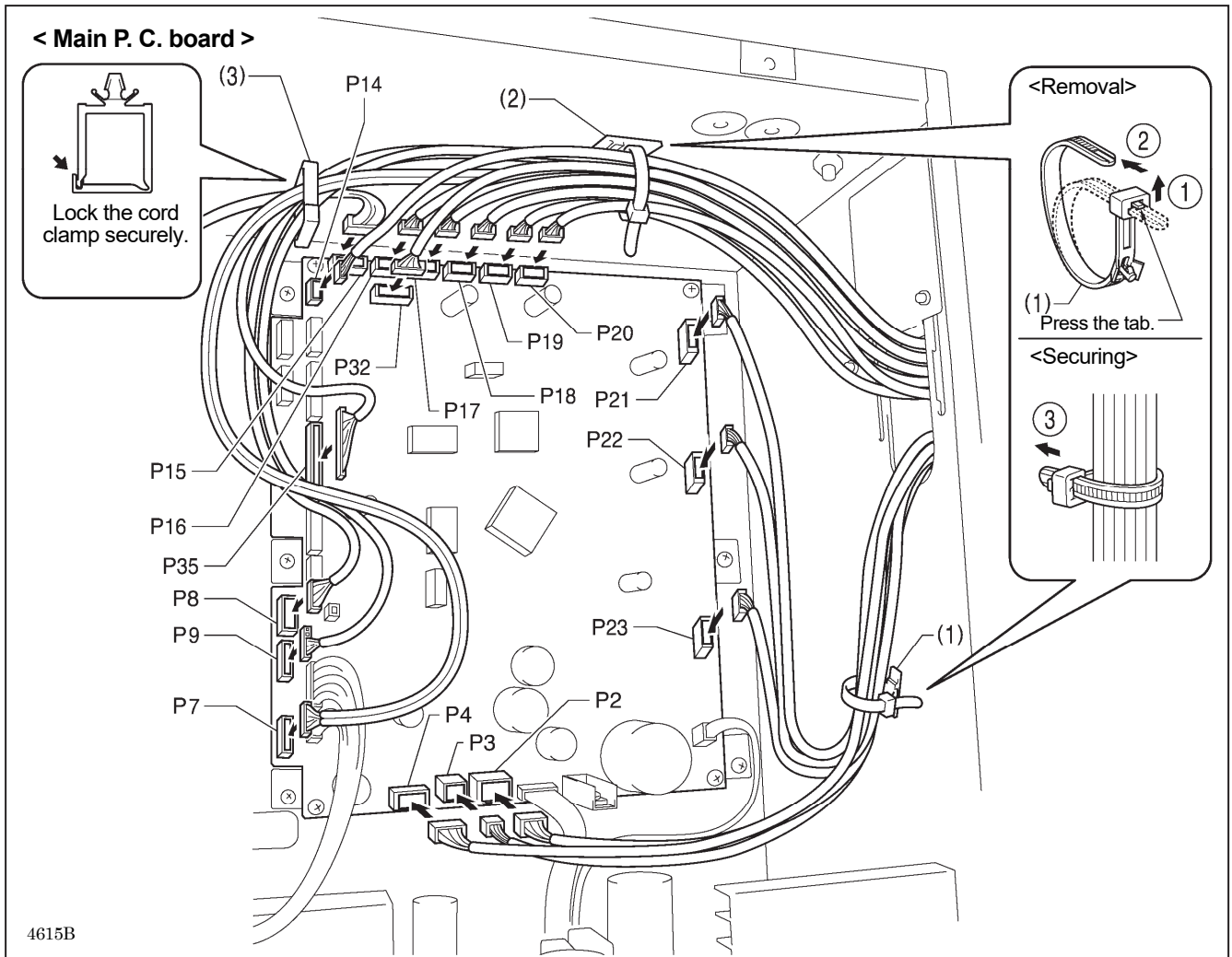

4615B

| Connectors | Connection location on main P. C. board | Cord clamps / cable ties |
|--|---|--------------------------|
| X pulse motor encoder [5-pin] White | P17 (X-ENC) | (2) |
| Y pulse motor encoder [5-pin] Blue | P18 (Y-ENC) | (2) |
| Presser foot pulse motor encoder [5-pin] Black | P19 (P-ENC) | (2) |
| Thread trimmer pulse motor encoder [5-pin] red | P20 (T-ENC) | (2) |
| Machine head switch [3-pin] | P14 (HEAD-SW) | (2) |
| Two-pedal foot switch [7-pin] White | P15 (PEDAL) | (2) |
| Machine head memory [6-pin] | P16 (HEAD-MEM) | (2) |
| LCD panel [8-pin] Red | P32 (PROGRAMER) | (2) |
| Thread trimmer solenoid [6-pin] | P2 (SOL1) | (1) |
| Digital tension solenoid [4-pin] | P3 (SOL2) | (1) |
| X pulse motor [4-pin] White | P21 (XPM) | (1) |
| Y pulse motor [4-pin] Blue | P22 (YPM) | (1) |
| Work clamp pulse motor [4-pin] Black | P23 (PPM) | (1) |
| Thread trimmer pulse motor [4-pin] red | P4 (TPM) | (1) |
| Home position sensor [12-pin] White | P8 (SENSOR1) | (2)(3) |
| STOP switch [6-pin] White | P9 (HEAD) | (2)(3) |
| Valve harness [12-pin] | P35 (EX-OUT1) | (2)(3) |
| Fan [6-pin] | P7 (SENSOR2) | (2)(3) |

NOTE: Route the X, Y and work clamp pulse motor harnesses so that they do not touch the power supply P.C. board at the bottom of the control box.

3. INSTALLATION

< Motor P. C. board >

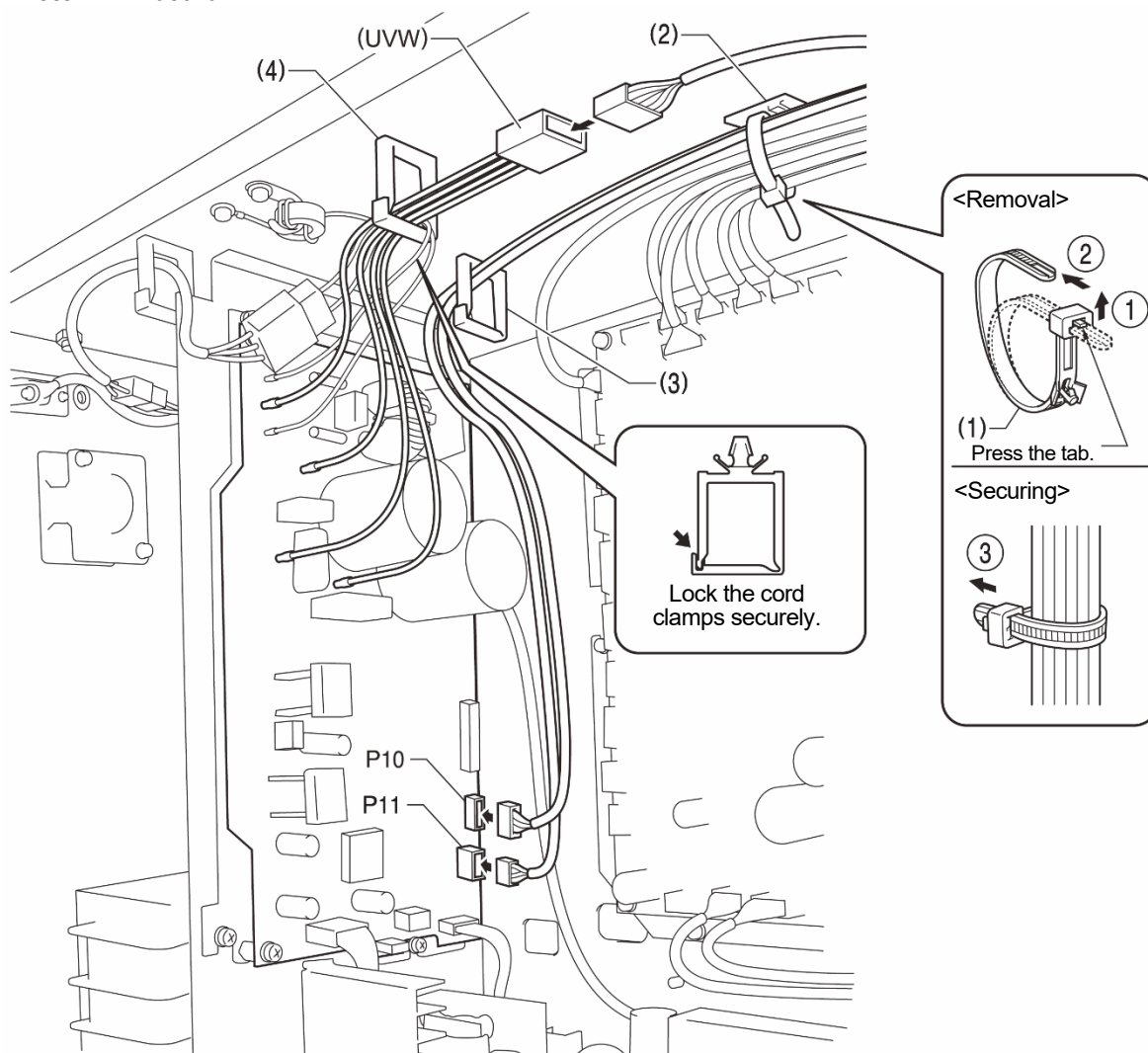

4616B

| Connectors | Connection location on motor P. C. board | Cord clamps |
|---------------------------|--|-------------|
| Upper shaft motor [4-pin] | (UVW) | (4) |
| Synchronizer [10-pin] | P11 (RESOLVER) | (2) (3) |
| LED [7-pin] | P10 (OPTION) | (2) (3) |

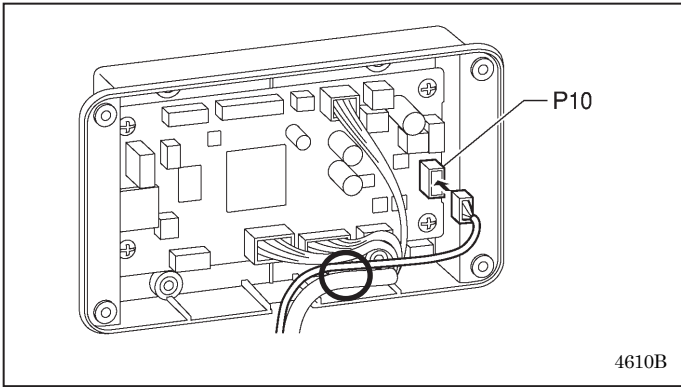

5. Connect the connector of the skipped stitch detection amplifier harness which leads from the machine head to P10 on the skipped stitch detection control P.C. board.
Use the accessory cable ties to secure the skipped stitch detection amplifier harness at the circle positions.

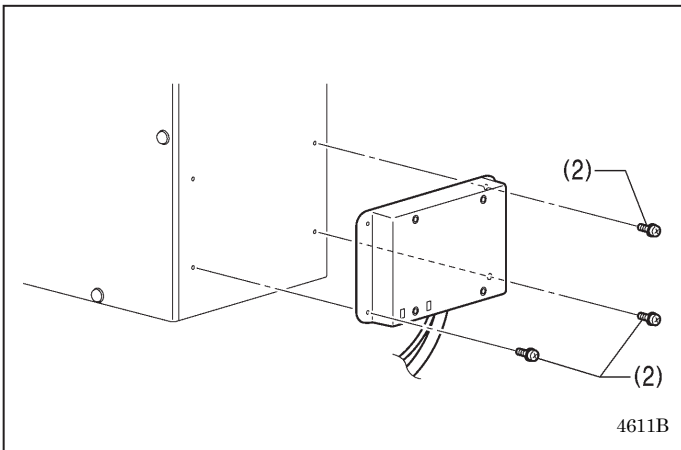

6. Loosen the three screws (2), and then install the skipped stitch detection control unit to the control box.

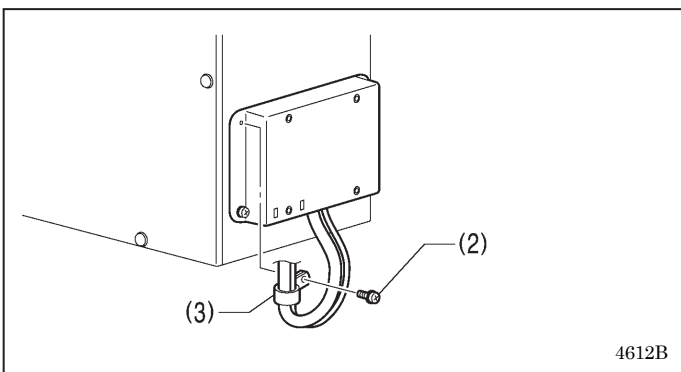

7. Tighten the clamp (3) with the screw (2) to secure the skipped stitch detection harness.

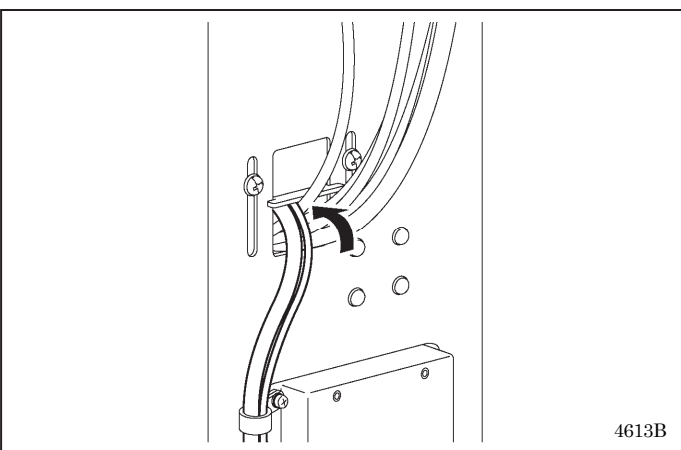

8. Pass the skipped stitch detection control harness through the hole in the control box.

3. INSTALLATION

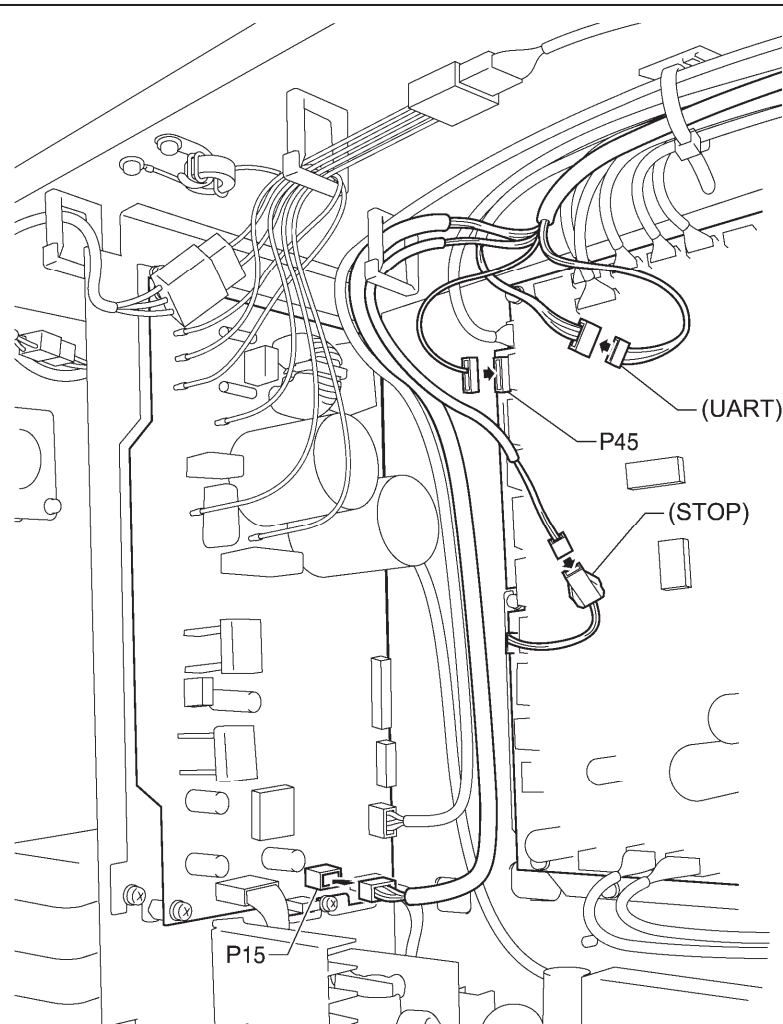

| Connectors | Connection location on motor P. C. board | Cord clamps |
|---------------------------|--|-------------|
| SDD enable [1-pin] | P45 (EX OUT3) | (2) |
| SDD communication [3-pin] | (UART) | (2) |
| SDD STOP_OUT [2-pin] | (STOP) | (2)(3) |
| SDD ENC [8-pin] | P15 (SDD_ENC) | (2)(3) |

9. Connect the connectors of the skipped stitch detection control harness which leads from the skipped stitch detection control unit to the main P.C. board and the motor P.C. board.

10. Loosen the cables outside the control box without stretching them too much inside the control box.

NOTE:

- Check that the connectors are facing the correct way, and then insert them firmly until they lock into place.
- Make sure that the connector does not get pulled out.

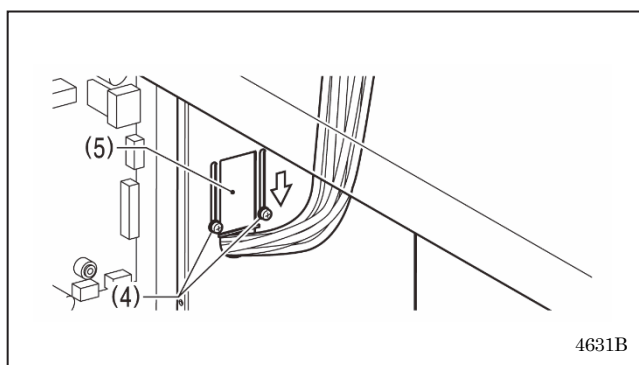

11. Close the cord presser plate (5) and tighten the two screws (4).

NOTE:

Close the cord presser plate (5) securely so that no foreign objects, insects or small animals can get inside the control box.

3-14. Connecting the ground wire

CAUTION



Be sure to connect the ground. If the ground connection is not secure, you run a high risk of receiving a serious electric shock, and problems with correct operation may also occur.

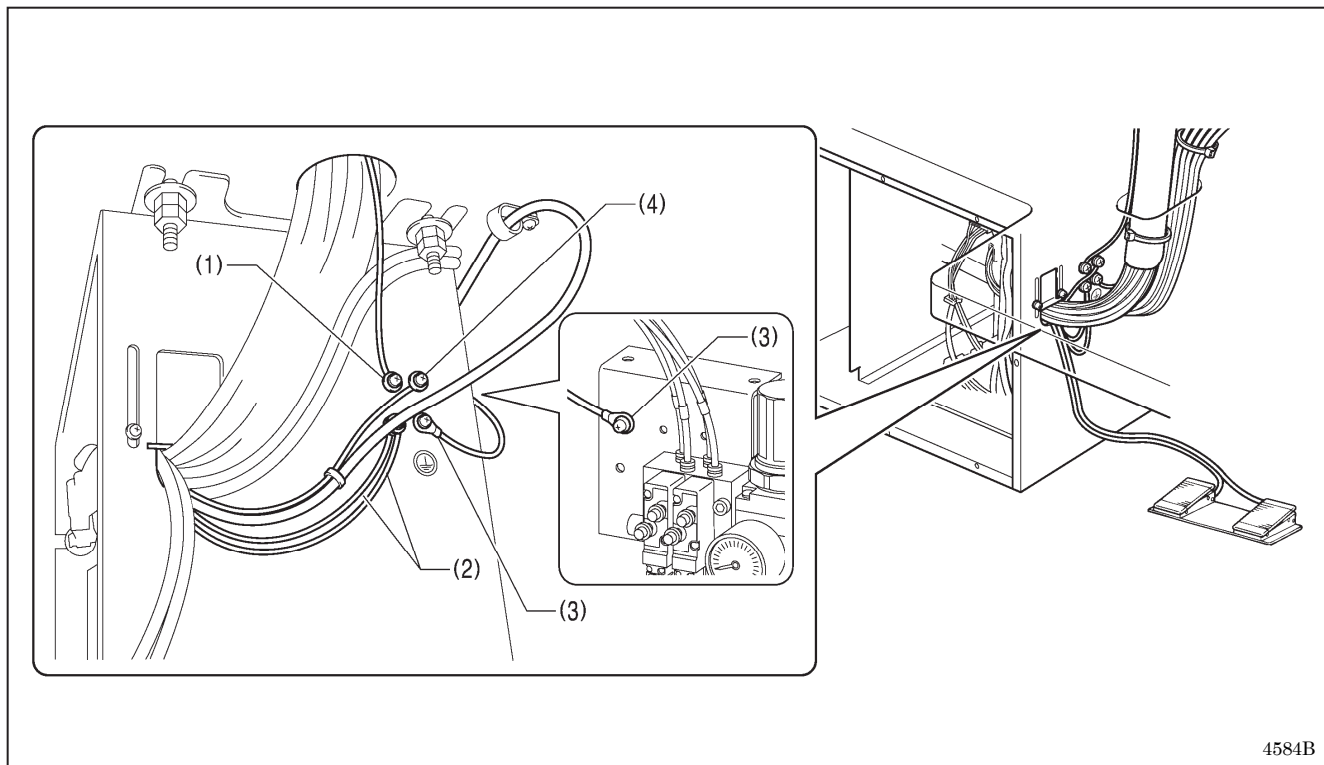

- (1) Ground wire from the machine head
- (2) Ground wires from two-pedal foot switch harnesses (2 wires)
- (3) Solenoid valve assembly ground wire
- (4) Ground wires from the LCD pedal

- Tighten the control box cover with the eight screws. Check that the cords are not clamped by the cover at this time.

NOTE: Make sure that the ground connections are secure in order to ensure safety.
Do not connect the ground wire (1) together with the ground wires (2) to (4).

3-15. Securing the cords and air tubes

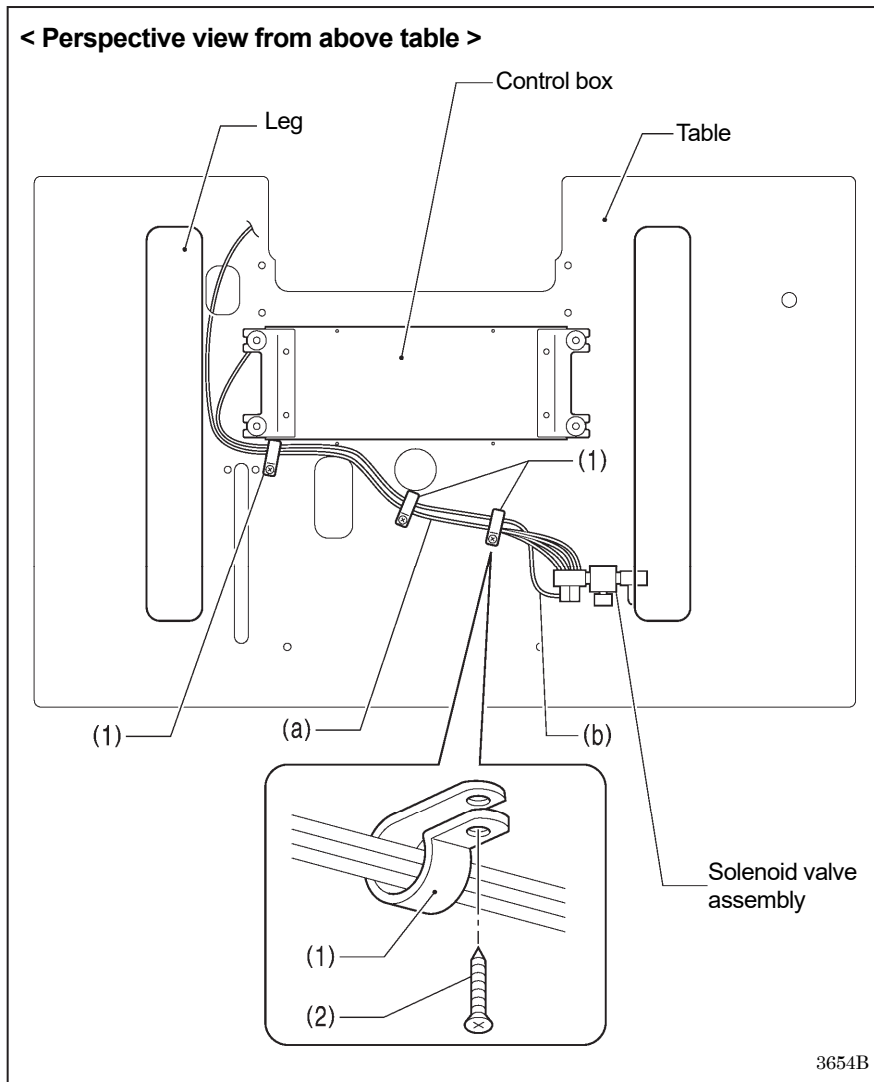

Secure the air tubes (a) and the solenoid valve assembly cord (b) together underneath the table with the three cord holders (1).

- (1) Cord holders [3 pcs.]
- (2) Wood screws [3 pcs.]

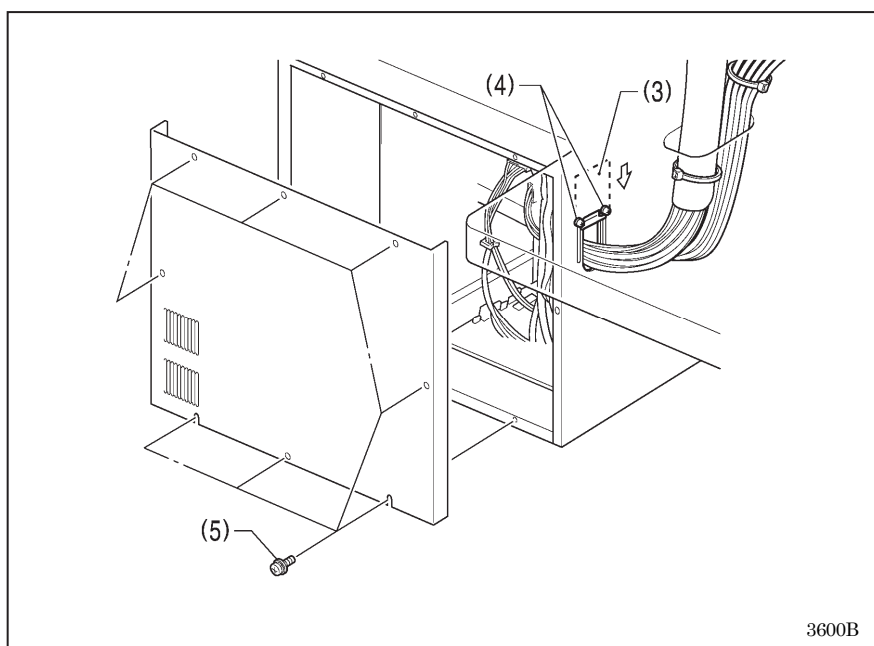

<Checking the cords>

1. Gently tilt back the machine head. (Refer to "3-5. Tilting back and returning the machine head".)
2. Check that none of the cords are being pulled.
3. Return the machine head to its original position.
4. Close the cord presser plate (3) in the direction of the arrow, and secure it by tightening the two screws (4).

NOTE:

Close the cord presser plate (3) securely so that no foreign objects, insects or small animals can get inside the control box.

5. Secure the cover of the control box by tightening the eight screws (5). Check that the cords are not clamped by the cover at this time.

3-16. Connecting the power cord

! CAUTION

Be sure to connect the ground. If the ground connection is not secure, you run a high risk of receiving a serious electric shock, and problems with correct operation may also occur.

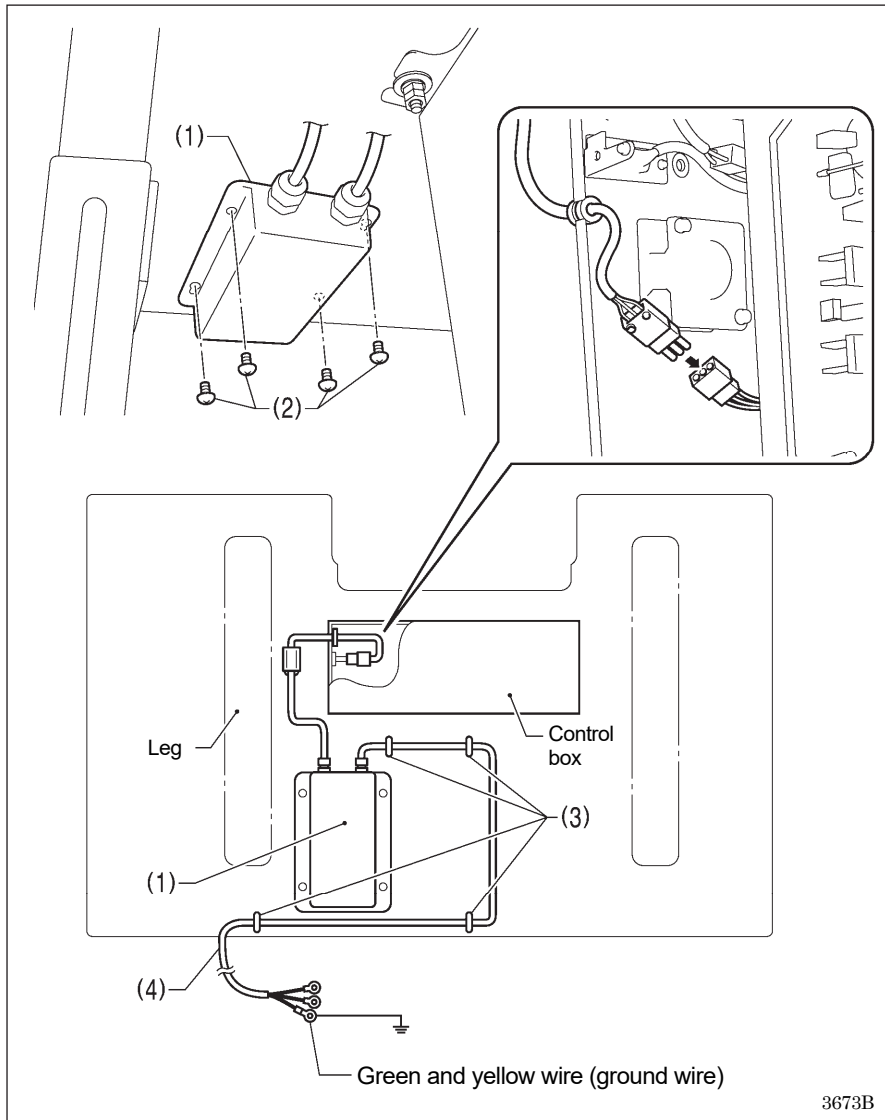

Connect cords that match the voltage specifications.

<EU specifications>

- (1) Filter box
- (2) Screws [4 pcs.]
- (3) Staples [4 pcs.]
- (4) Power cord

1. Attach an appropriate switch and cable to the power cord (4). (The green and yellow wire is the ground wire.)
2. Insert the power plug into a properly-grounded electrical outlet.

NOTE:

- Take care when tapping in the staples (3) to make sure that they do not pierce the cords.
- Do not use extension cords, otherwise machine operation problems may result.

3. INSTALLATION

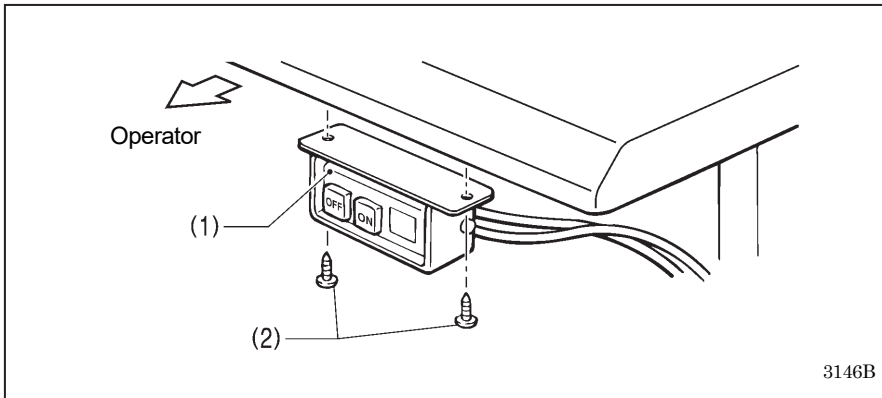

Connect cords that match the voltage specifications.

<200 V system >

- (1) Power switch
- (2) Wood screws [2 pcs.]

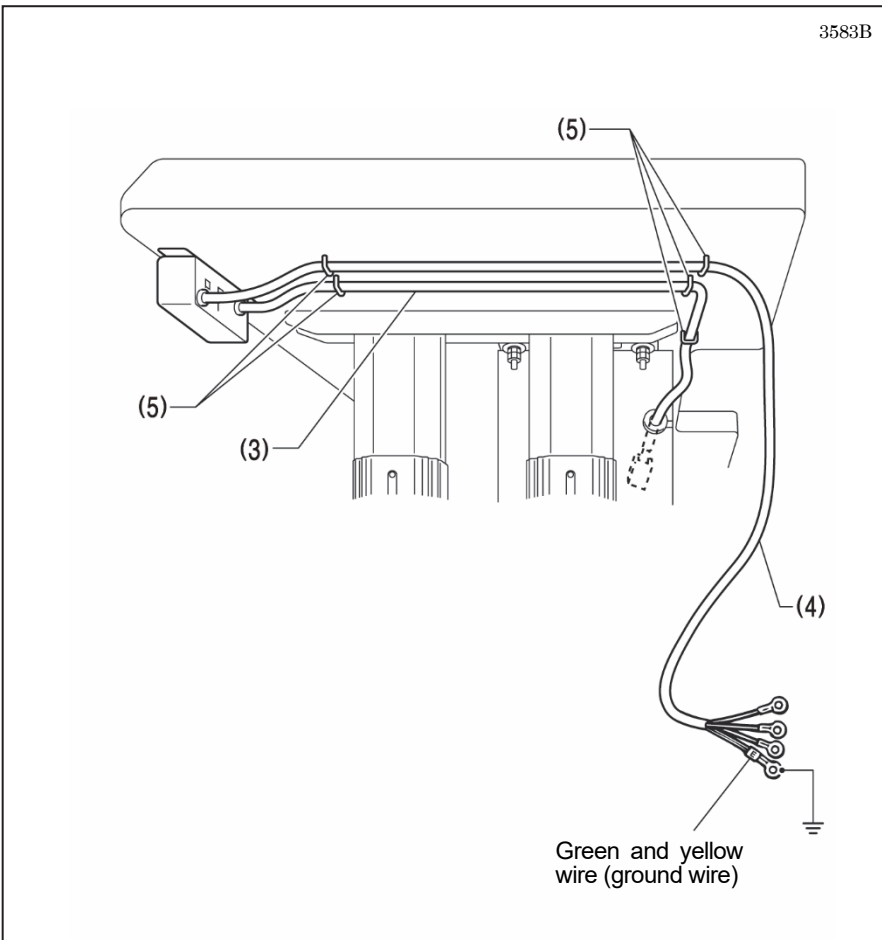

- (3) 3-pin power supply connector
- (4) Power cord
- (5) Staples [5 pcs.]

1. Attach an appropriate plug to the power cord (4). (The green and yellow wire is the ground wire.)
2. Insert the power plug into a properly-grounded electrical outlet.

NOTE:

- Take care when tapping in the staples (5) to make sure that they do not pierce the cords.
- Do not use extension cords, otherwise machine operation problems may result.

3-17. Installing the eye guard

! CAUTION



Attach all safety devices before using the sewing machine.
If the machine is used without these devices attached, injury may result.

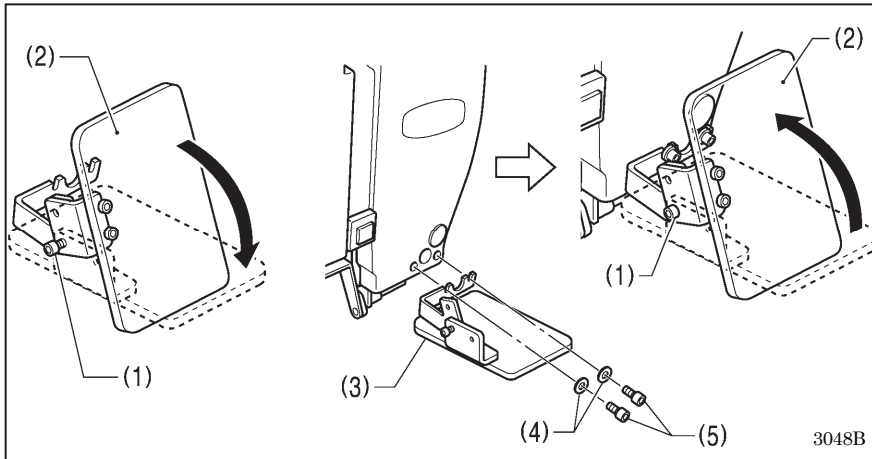

- (1) Bolt (loosen)
- (2) Eye guard (tilt forward)
- (3) Eye guard assembly
- (4) Plain washers [2 pcs.]
- (5) Bolts [2 pcs.]

After installing the eye guard assembly (3), return the eye guard (2) to its original angle, and then tighten the bolt (1) to secure it in place.

3-18. Installing the cotton stand

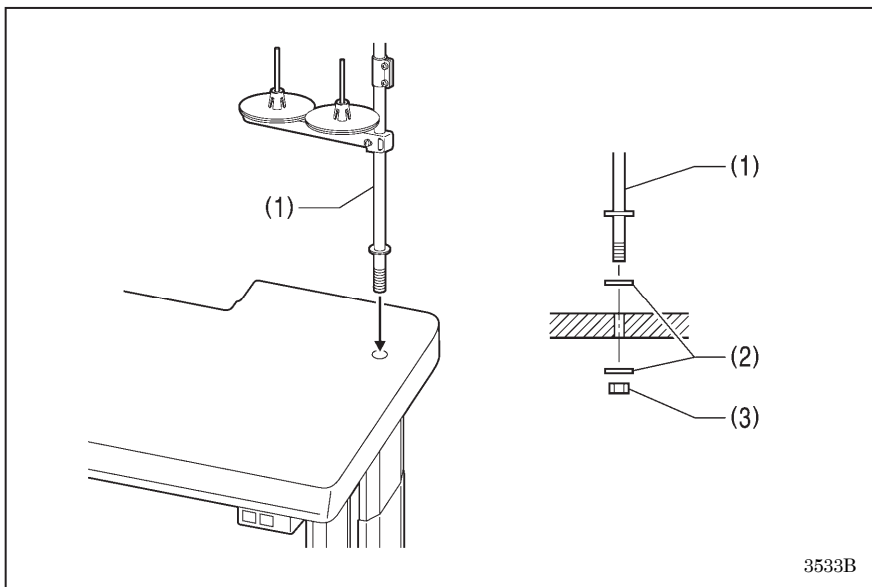

- (1) Cotton stand

NOTE:

Securely tighten the nut (3) so that two washers (2) are securely clamped so that the cotton stand (1) does not move.

3-19. Lubrication

CAUTION



Do not connect the power cord until lubrication is complete.
If the foot switch is depressed by mistake, the sewing machine might start operating and injury could result.



Be sure to wear protective goggles and gloves when handling the lubricating oil and grease, so that they do not get into your eyes or onto your skin. If the oil and grease get into your eyes or onto your skin, inflammation can result. Furthermore, do not drink or eat the lubricating oil or grease. They may cause diarrhea or vomiting. Keep the oil out of the reach of children.

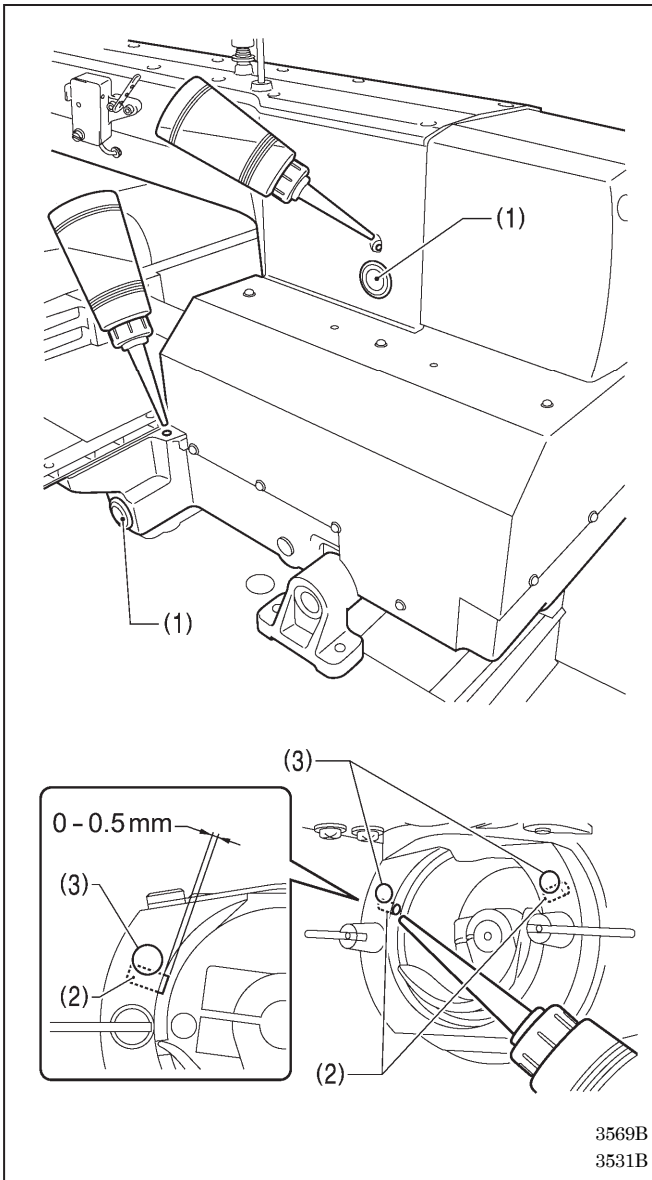

- The sewing machine should always be lubricated and the oil supply replenished before it is used for the first time, and also after long periods of non-use.
- Use only the lubricating oil <JX Nippon Oil & Energy Corporation Sewing Lube N10; VG10> specified by Brother.
 - * If this type of lubricating oil is difficult to obtain, the recommended oil to use is <Exxon Mobil Esstex SM10; VG10>.

1. Fill the arm oil tank and the bed oil tank with oil.

NOTE:

Be sure to add more oil when the oil level drops down to about one-third full in the oil gauge window (1). If the oil drops below the one-third full level in the oil gauge window (1), there is the danger that the sewing machine may seize during operation.

2. Pour oil in through the two holes of the shuttle race base assembly so that the felt (2) is lightly moistened. If it is difficult to add oil, you can also remove the rubber cap (3) and pour in the oil through the hole.

NOTE:

- The two pieces of felt (2) should normally project by 0 to 0.5 mm from the hook race. Be careful not to push in the felt (2) when lubricating.
- If there is no more oil on the felt (2) of the shuttle race base assembly, problems with sewing may result.

3-20. Checking the machine head switch

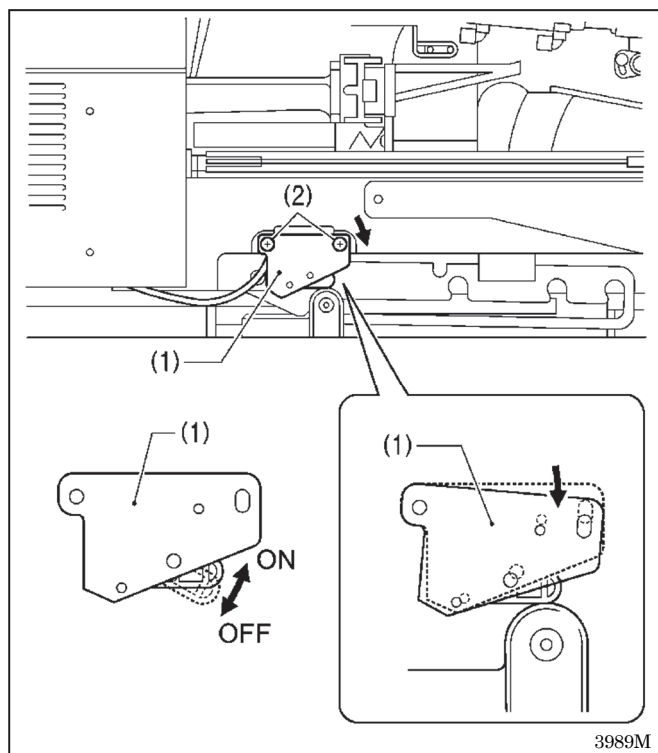

1. If the machine head is tilted back, gently return it to its original position. (Refer to "3-5. Tilting back and returning the machine head".)
2. Turn on the power switch.
3. Check that no error numbers appear on the LCD panel.

<If error [E050], [E051] or [E055] is displayed >

If the machine head switch (1) is not turned on, error [E050], [E051] or [E055] will occur.

Adjust the installation position of the machine head switch (1).

1. Turn off the power.
2. Loosen the two screws (2).
3. Push down the right side of the machine head switch (1) so that the machine head switch (1) turns on, and then tighten the two screws (2).
4. Turn on the power and check that no error numbers are displayed.

3989M

4. PREPARATION BEFORE SEWING

4-1. Installing the needle

CAUTION



Turn off the power switch before installing the needle.

If the foot switch is depressed by mistake, the sewing machine might start operating and injury could result.

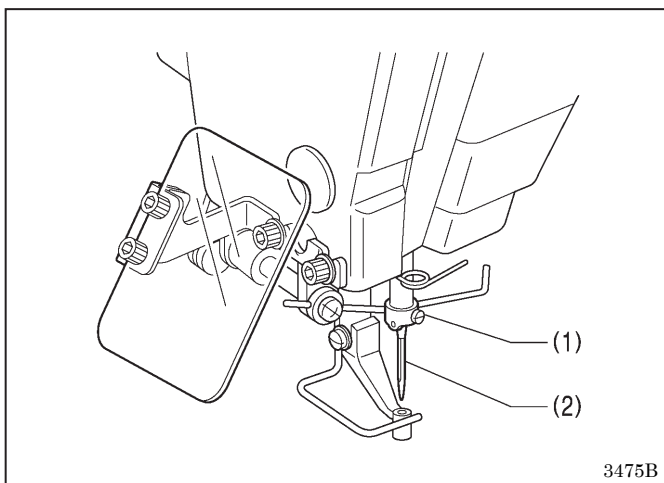

1. Loosen the set screw (1).
2. Insert the needle (2) in a straight line as far as it will go, making sure that the long groove on the needle is at the front, and then securely tighten the set screw (1).

4-2. Start switch operation method

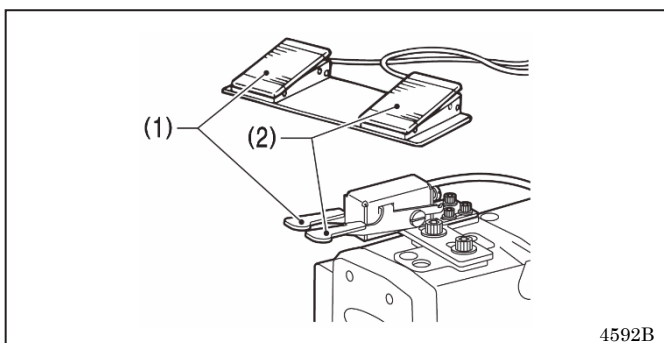

When the work clamp switch (1) is depressed, the intermittent presser foot (3) and the work clamp (4) are lowered, and when the start switch (2) is depressed, the sewing machine starts operating.

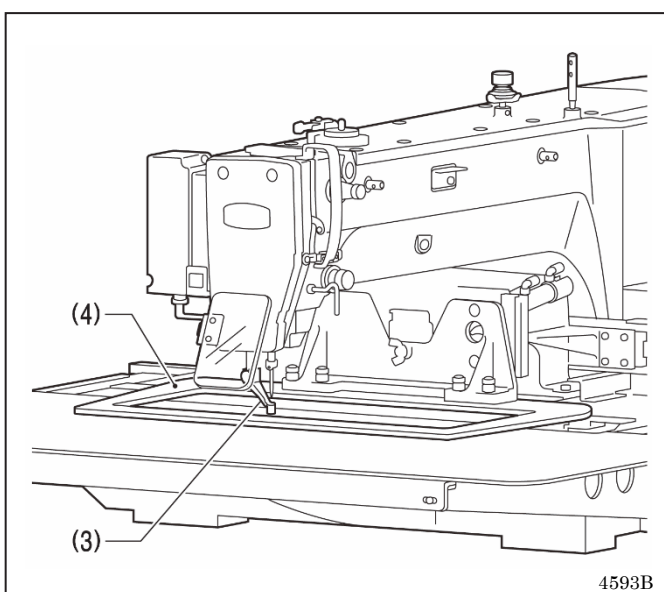

4-3. Threading the upper thread

Thread the upper thread correctly as shown in the illustration below.

- * When using threading mode for threading, the thread can be threaded more easily.
(Refer to "Threading mode" on the next page.)

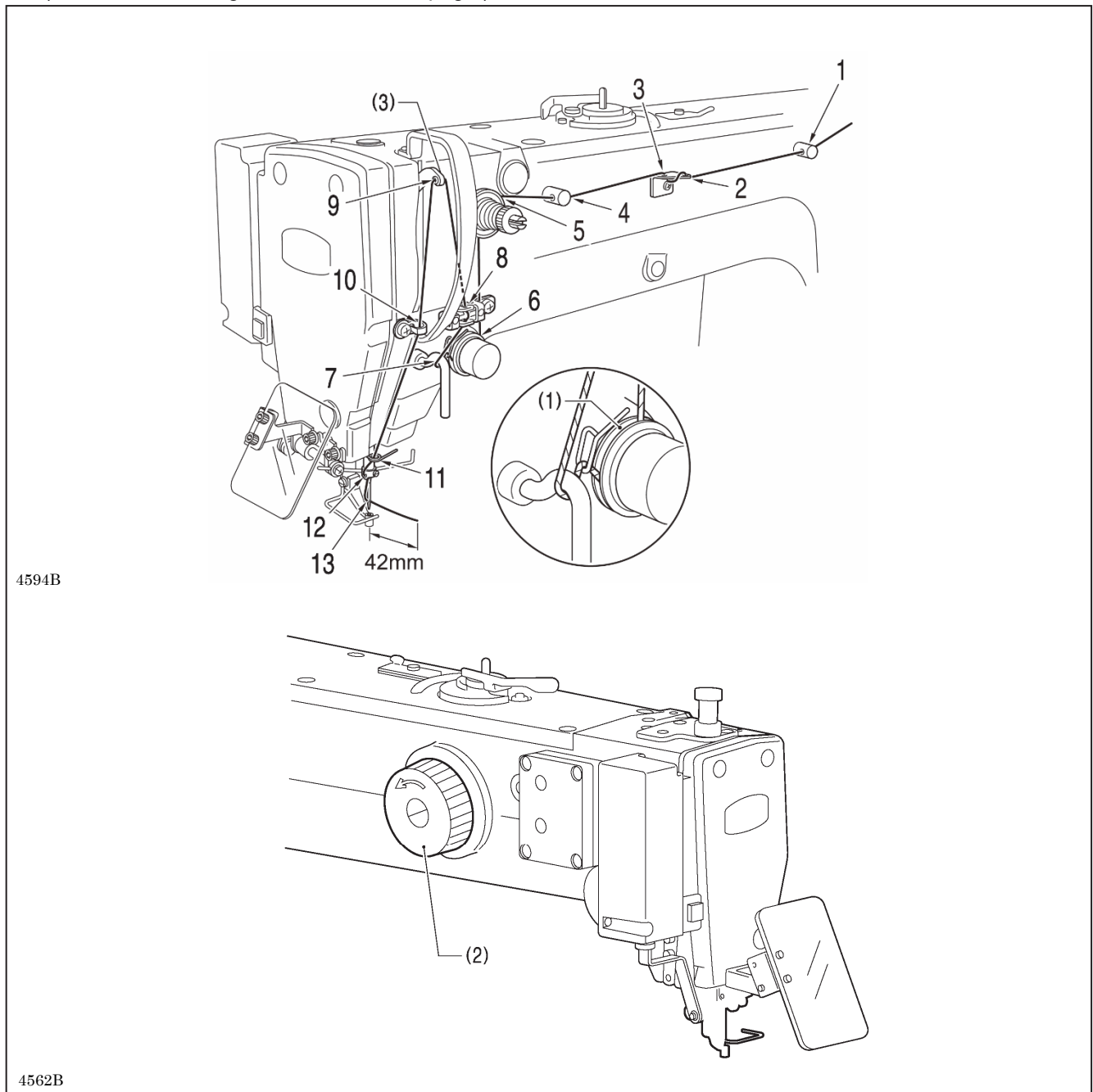



- Turn the machine pulley (2) and raise the thread take-up (3) to its highest position before threading the upper thread.
(This will make threading easier and it will prevent the thread from coming out at the sewing start.)
- When threading the thread through the needle, allow a distance of approximately 42 mm between the needle hole and the end of the thread.
If it is too long, the thread may become tangled, and if it is too short, the thread may pull out at the sewing start.

4. PREPARATION BEFORE SEWING

<Threading mode>

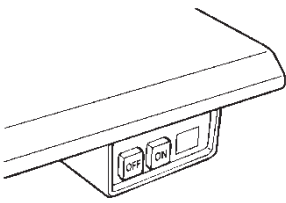
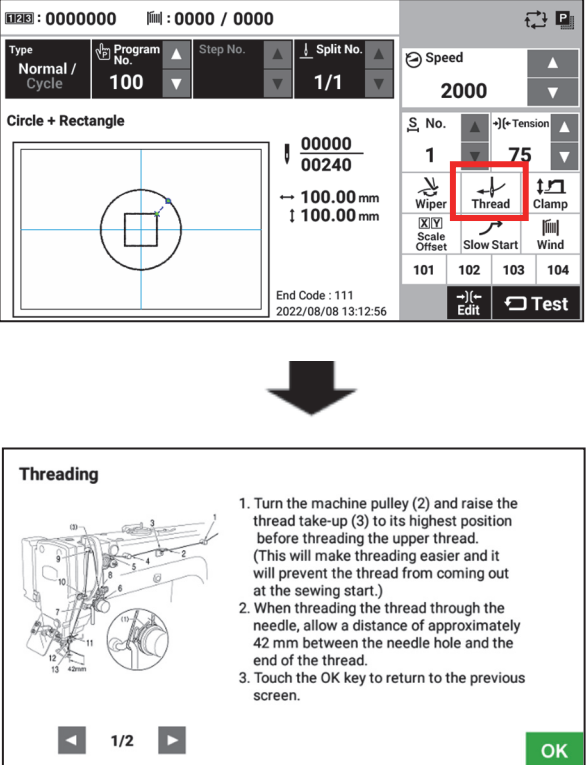
Threading mode is safe because the sewing machine will not start even when the start switch is depressed.

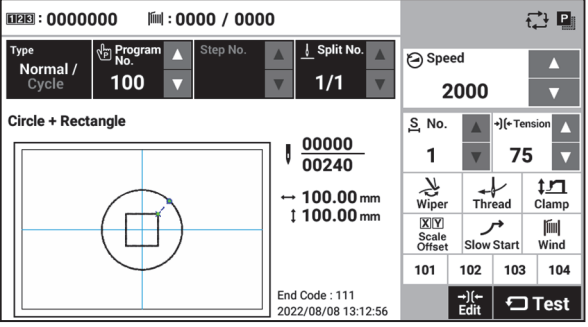
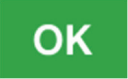
| | | |
|----------|---|--|
| 1 |  <p>3055B</p> | <p>Turn on the power.</p> |
| 2 |  <p>Threading</p> <ol style="list-style-type: none"> 1. Turn the machine pulley (2) and raise the thread take-up (3) to its highest position before threading the upper thread. (This will make threading easier and it will prevent the thread from coming out at the sewing start.) 2. When threading the thread through the needle, allow a distance of approximately 42 mm between the needle hole and the end of the thread. 3. Touch the OK key to return to the previous screen. | <p>Touch the Thread key on the screen.</p>  <ul style="list-style-type: none"> • Work clamp will drop. • The tension discs will open. |
| 3 | <p>Threading the thread.</p> | |
| 4 | <p>Ending threading mode</p> <p>The display will return to the previous screen.</p>  | <p>Touch the OK key on the screen.</p>  <ul style="list-style-type: none"> • The work clamp will return to where it was before threading mode was started. |

4-4. Winding the lower thread

⚠ CAUTION



Do not touch any of the moving parts or press any objects against the machine while winding the lower thread, as this may result in personal injury or damage to the machine.

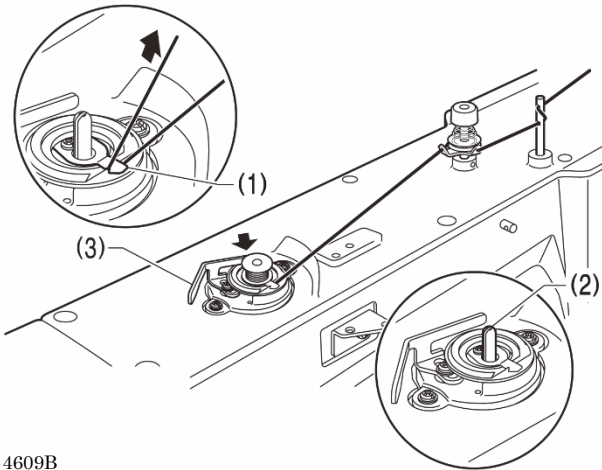

4609B

1. Thread the thread as shown in the diagram, hook it onto the knife (1), and then pull the thread in the direction of the arrow to cut it.
2. Place the bobbin onto the bobbin winder shaft (2).
3. Push the bobbin presser arm (3).
4. Turn on the power.
5. Lower the work clamp and then operate the start switch. Home position detection will be carried out.
6. Touch the Wind key (4) on the screen. The display will switch to the thread winding mode screen.
7. Check that the needle does not touch the work clamp, and then lower the work clamp and operate the start switch.
8. Keep depressing the start switch until the thread has finished being wound on.
9. Once winding of the set amount of thread is complete (80% to 90% of the bobbin diameter), the bobbin presser arm (3) will return automatically.
10. Remove the bobbin, hook the thread onto the knife (1), and then pull the thread in the direction of the arrow to cut it.
11. Touch the OK key to return to the previous screen.

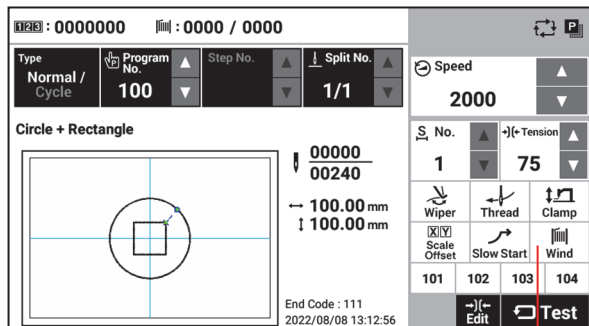

(4)

If the thread tension is too strong, the thread may pull out and be lost at the start of winding. In such cases, pull out about 10 mm of thread from the thread tension toward the sewing machine beforehand to make winding easier.

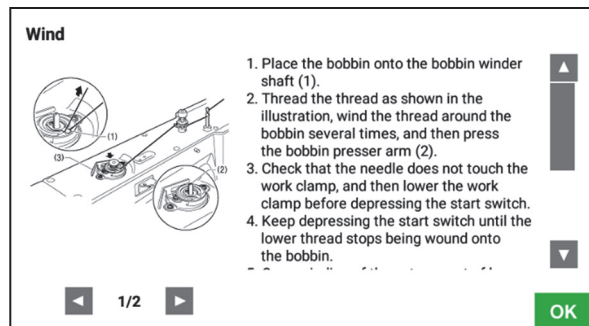

4. PREPARATION BEFORE SEWING

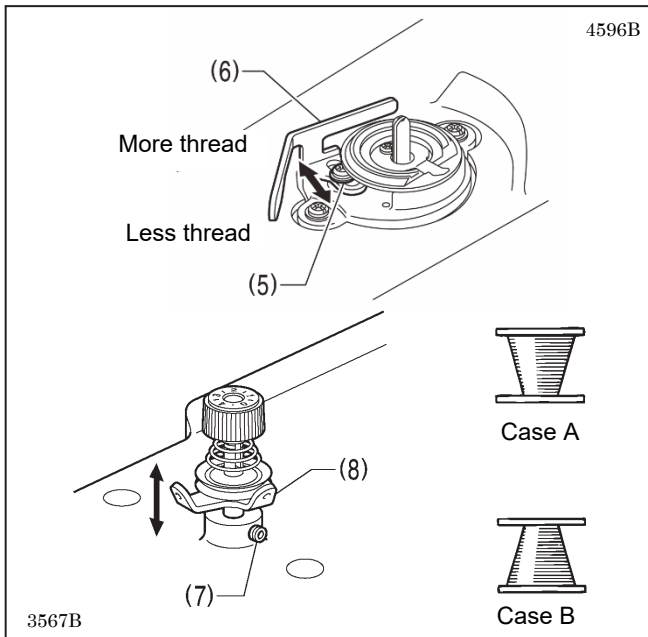

Adjusting the bobbin winding amount

Loosen the screw (5) and move the bobbin presser (6).

If the thread winds onto the bobbin unevenly

Loosen the set screw (7) and move the bobbin winder tension assembly (8) up and down to adjust.

* For case A, move the bobbin winder tension assembly (8) down, and for case B, move it upward.

4-5. Installing the bobbin case

CAUTION



Turn off the power switch before installing the bobbin case.

If the foot switch is depressed by mistake, the sewing machine might start operating and injury could result.

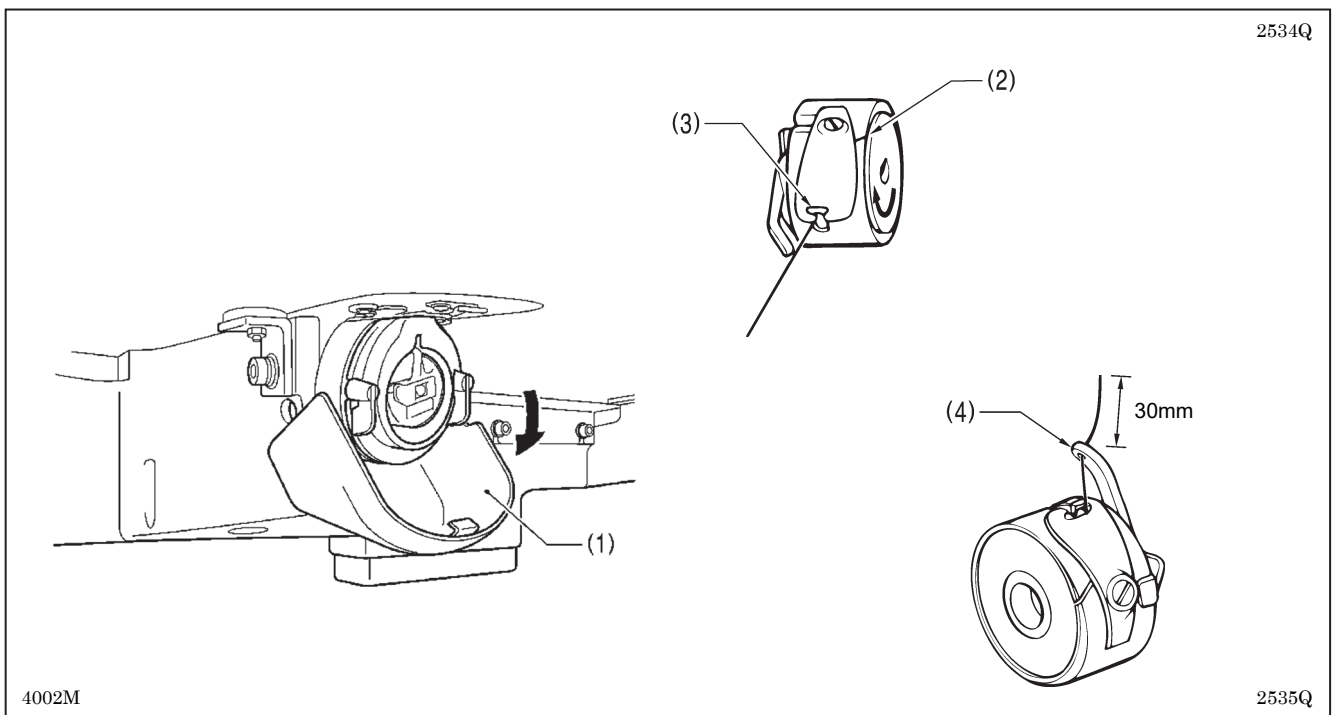

1. Pull the shuttle race cover (1) downward to open it.
2. While holding the bobbin so that the thread winds to the right, insert the bobbin into the bobbin case.
3. Pass the thread through the slot (2) and pull it out from the thread hole (3).
4. Check that the bobbin turns in the direction of the arrow when the thread is pulled.
5. Pass the thread through the lever thread hole (4), and then pull out approximately 30 mm of thread.
6. Hold the latch on the bobbin case and insert the bobbin case into the rotary hook.

4-6. Thread tension

[Thread tension reference]

| Specifications | Material thickness (Reference) | Air bag |
|---|-----------------------------------|-------------------|
| Upper thread | Corresponding to #20 | Air bag mechanism |
| Lower thread | Corresponding to #20 | Air bag mechanism |
| Upper thread tension (N) [Tension value] | 1.4 – 1.8 [140 - 180] *1 | 2 – 3 |
| Lower thread tension (N) | 0.3 – 0.4 | 0.9 – 1.3 |
| Pre-tension (N) | 0.2 – 0.4 | 0.8 – 1.2 |
| Needle | DP x 17 #19 | DP x 17 #24 |
| Normal sewing speed | 2,000 sti/min | 2,000 sti/min |

*1 This is the tension value when the pretension is 0.2 N.

4-6-1. Lower thread tension

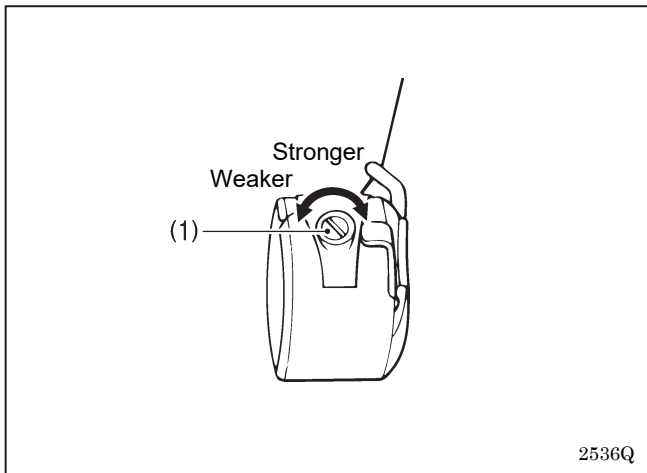

2536Q

Adjust the thread tension to the weakest possible tension by turning the thread tension nut (1) until the bobbin case will not drop by its own weight while the thread end coming out of the bobbin case is held.

4-6-2. Upper thread tension

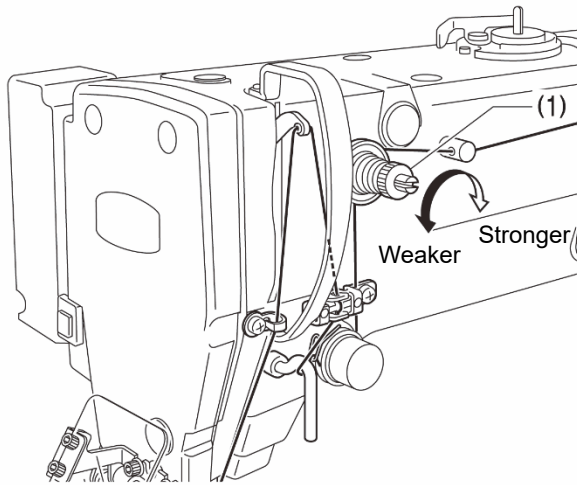

4597B

Use the digital tension to adjust the tension as appropriate for the material being sewn. (Refer to “Setting the tension value” below.)

Turn the tension nut (1) (sub-tension) to adjust so that the upper thread trailing length is about 42 mm.

[Sewing operation screen]

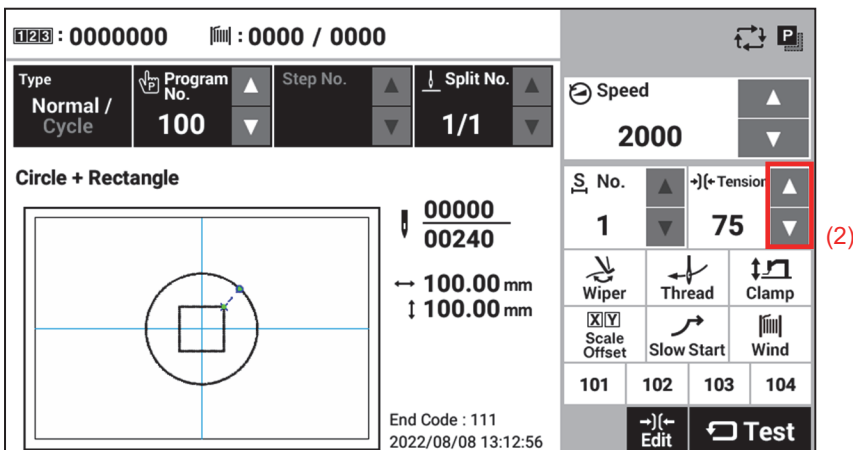

Setting the tension value

Touch the Δ and ∇ keys (2) on the sewing operation screen to increase or decrease the Tension value.

4-7. Starting up

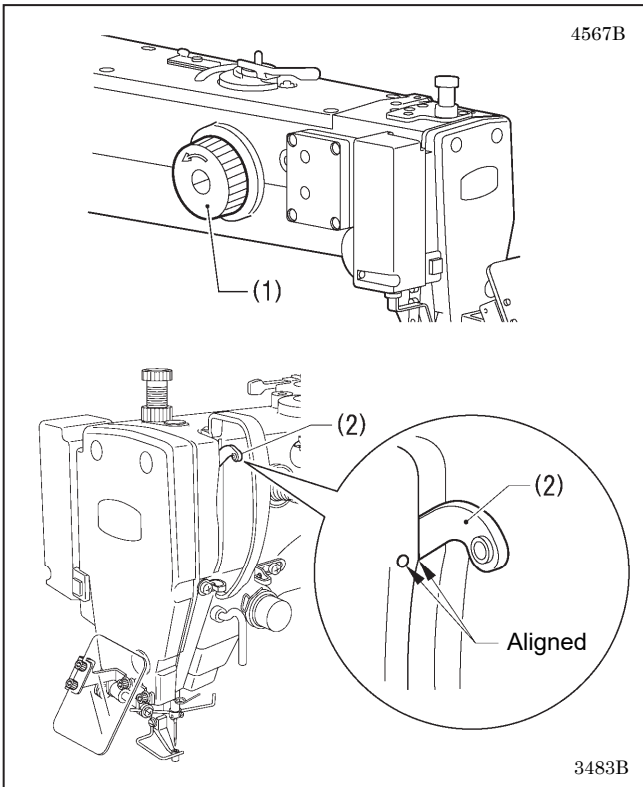

Before turning on the power, check that the needle bar is at the needle up stop position.

Turn the pulley (1) in the direction of the arrow until the ridge at the bottom of the thread take-up (2) is aligned with the index mark.

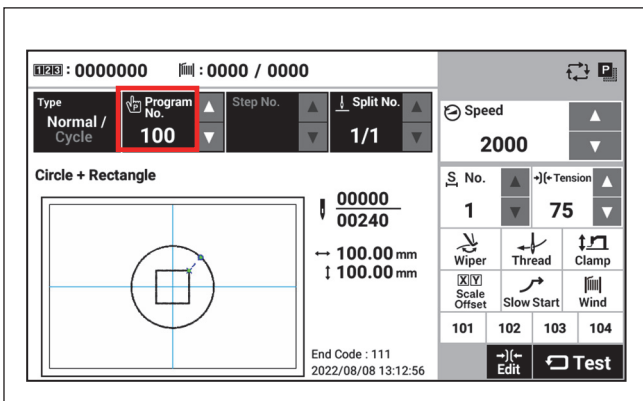

Turn on the power.

If a program has been registered, the program number and a preview of the sewing pattern will be displayed. No programs are registered at the time of shipment from the factory, and so "---" is displayed as the program number (No.).

For details on the sewing data reading method, refer to "3. USING STORAGE MEDIA" in the "LCD Panel/Operation Panel" Instruction Manual".

4-8. LED light operation method

CAUTION



Do not bring your hands close to moving parts such as the needle and the work clamp when adjusting the brightness of the LED light.

The sewing machine may operate if the start switch is pressed by mistake, which could result in serious injury.

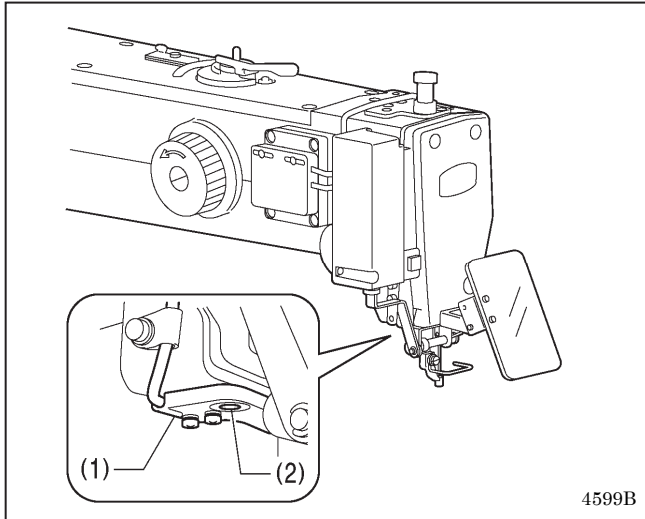

There is an LED light at the back of the needle bar. The brightness of the LED light (1) can be changed in six steps by pressing the switch (2). It switches off during sewing.

5. SEWING

! WARNING



Do not allow any liquids to get onto this sewing machine, otherwise fire, electric shocks or operating problems may occur.



If any liquid gets inside the sewing machine (machine head or control box), immediately turn off the power and disconnect the power plug from the electrical outlet, and then contact the place of purchase or a qualified technician.

! CAUTION



Turn off the power switch at the following times.

If the foot switch is depressed by mistake, the sewing machine might start operating and injury could result.

- When replacing the bobbin and needle
- When not using the machine and when leaving the machine unattended



Do not touch any of the moving parts or press any objects against the machine while sewing, as this may result in personal injury or damage to the machine.

5-1. Sewing

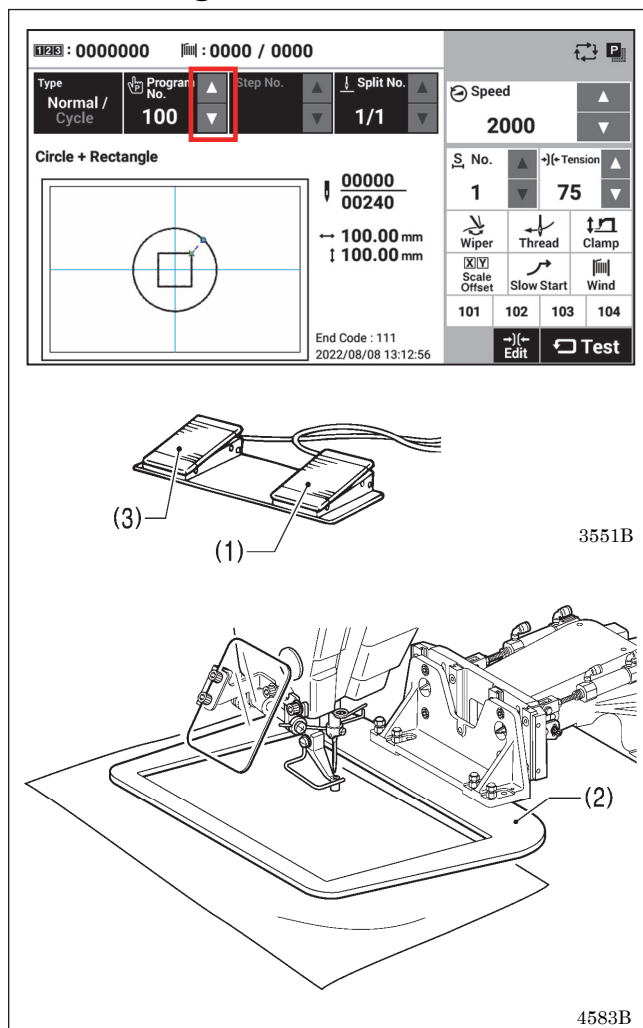

1. Turn on the power.
2. Touch the \triangle or ∇ key to select the number for the program to be sewn.

* For details on reading sewing data from SD cards and USB memory devices, refer to "3-4. Importing items of sewing data separately" in the "LCD panel/Operation pane" Instruction Manual.

3. Lower the work clamp (2) and then depress the start switch (1).
Home position detection will be carried out.
4. Place the materials under the work clamp (2).
5. Depress the work clamp switch (3).
The work clamp (2) will be lowered.
6. Depress the start switch (1).
The sewing machine will start sewing.
7. After sewing is completed, the thread trimmer will operate. And then the work clamp (2) will be raised.

Use a work clamp which will hold the material securely so that it does not slip. If the material slips process them so that the material does not slip.

5-2. Using the STOP switch

If you press the emergency stop switch (1) to during actual sewing, an error dialog box will be displayed and the sewing machine will immediately stop.

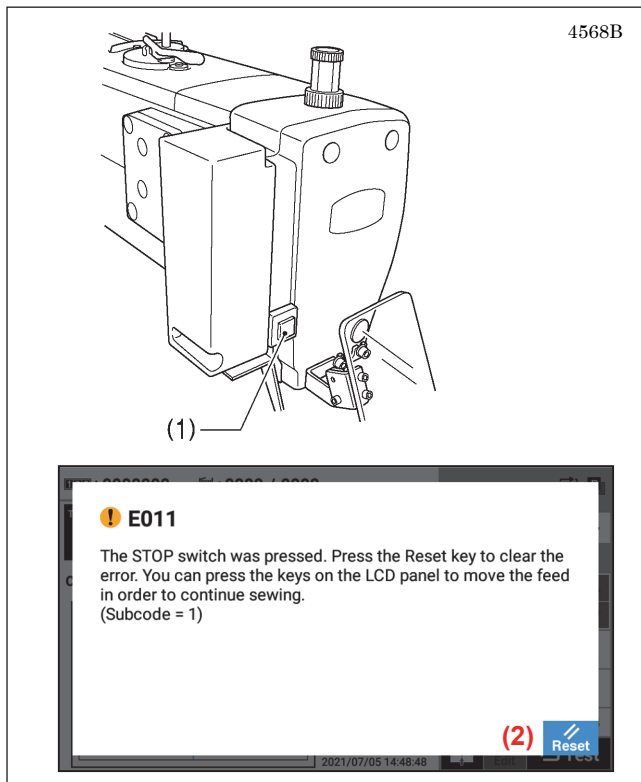

<Clearing>

1. Touch the Reset key (2).
 - The thread will be trimmed, and then the error dialog box on the screen will disappear and the buzzer will stop.
2. A dialog box asking you to confirm if you want to continue sewing will be displayed.

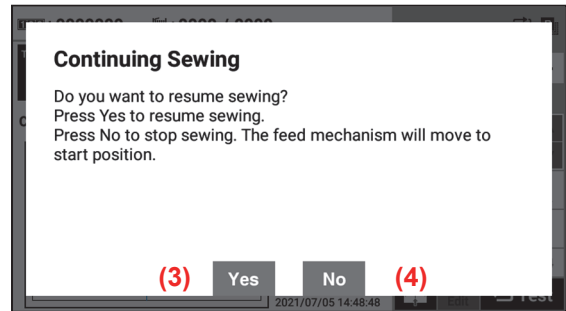

<Continuing sewing from a stopping point>

If the thread breaks or the lower thread runs out during sewing, you can then continue sewing from the point where the thread broke or ran out.

| | | |
|----------|--|--|
| 1 | | <p>Touch "Yes" (3) to return to the resewing standby screen.</p> |
| 2 | | <p>Touch the ◀️🪡 and 🪡▶️ keys (5) and (6) on the screen to return to the position where sewing is to be resumed.</p> <p>When you touch the ◀️🪡 key (5), the feed will move backward by 1 stitch, and when you touch the 🪡▶️ key (6), the feed will move forward by 1 stitch.</p> |
| 3 | | <p>Depress the start switch. The sewing machine will start operating and sewing will start.</p> |

<Returning to the sewing start position without continuing sewing>

If you do not wish to continue sewing, touch "No" (4).

- After home position detection is carried out, the mechanism will return to the sewing start position.

6. CLEANING

! CAUTION



Turn off the power switch before carrying out cleaning.

If the foot switch is depressed by mistake, the sewing machine might start operating and injury could result.



Be sure to wear protective goggles and gloves when handling the lubricating oil and grease, so that they do not get into your eyes or onto your skin. If the oil and grease get into your eyes or onto your skin, inflammation can result.

Furthermore, do not drink or eat the lubricating oil or grease. They may cause diarrhea or vomiting.

Keep the oil out of the reach of children.

6-1. Cleaning the rotary hook

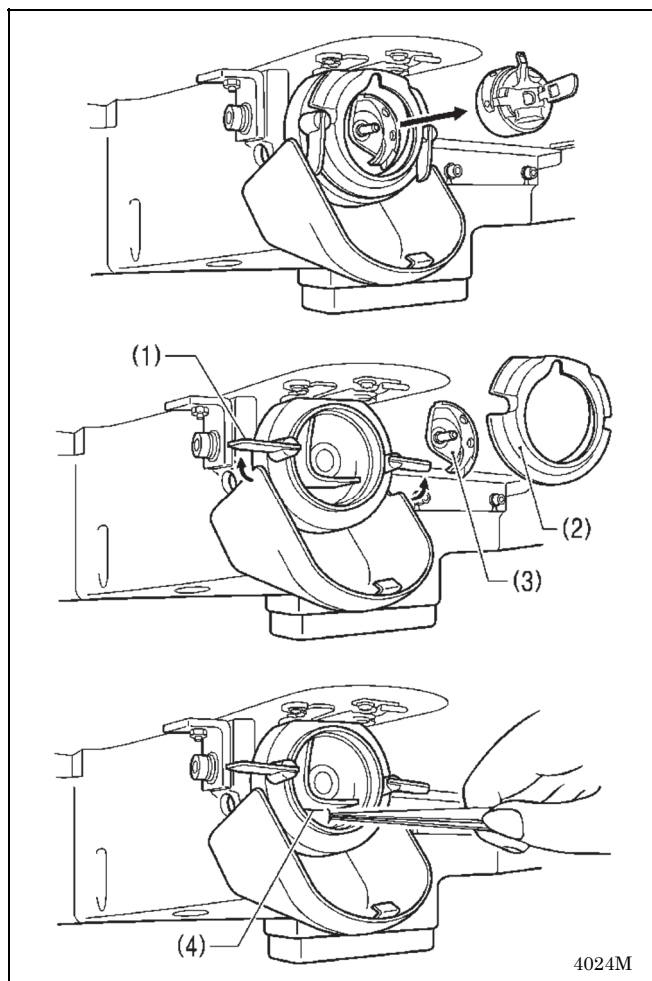

1. Pull the shuttle race cover downward to open it, and then remove the bobbin case.

2. Open the setting claw (1) in the direction indicated by the arrow, and then remove the shuttle race base (2) and the shuttle hook (3).

3. Clean all the dust and lint from around the driver (4), the top of the rotary hook thread guide and the shuttle race.

6-2. Draining the oil

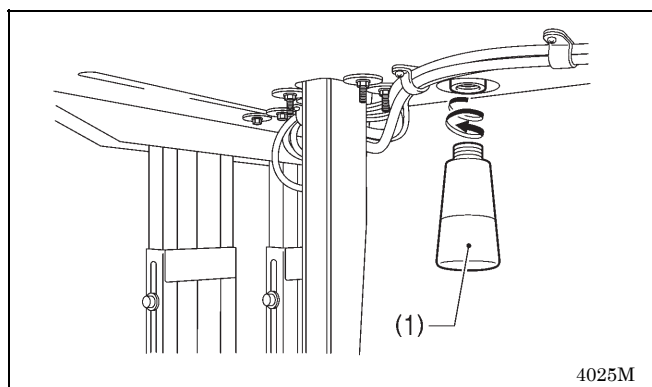

1. Remove and empty the oiler (1) whenever it is full.

2. After emptying oiler (1), screw it back into its original position.

NOTE:

Dispose of waste oil correctly in accordance with local regulations.

6-3. Checking the regulator

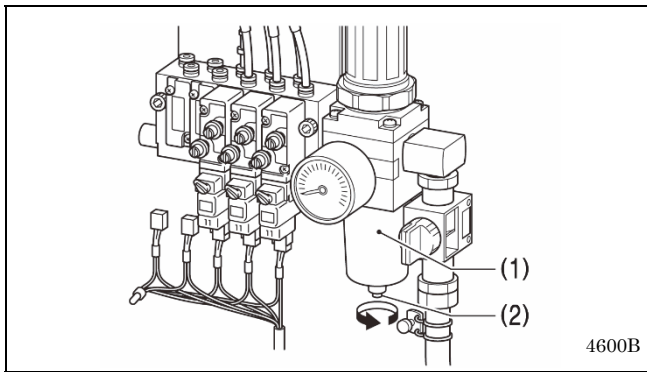

1. If water collects in the bottle of the regulator (1), turn the drain cock (2) in the direction of the arrow to drain the water.
2. After draining the water, tighten the drain cock (2).

6-4. Cleaning the control box air inlet ports

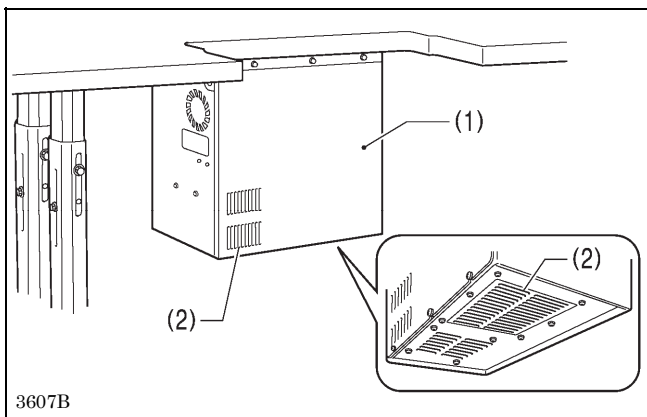

Use a vacuum cleaner to clean the filter in the air inlet ports (2) of the control box (1) at least once a month.

6-5. Cleaning the eye guard

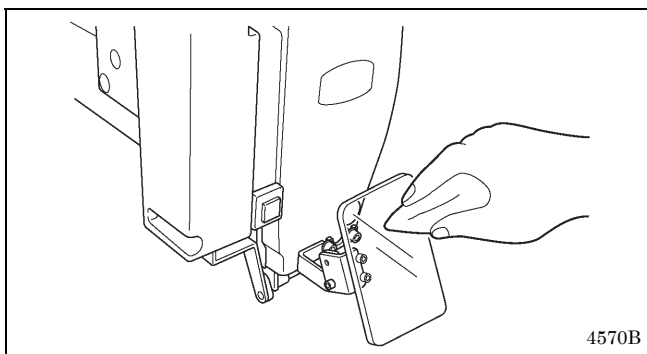

Wipe the eye guard clean with a soft cloth.

NOTE:

Do not use solvents such as kerosene or thinner to clean the eye guard.

6-6. Checking the needle

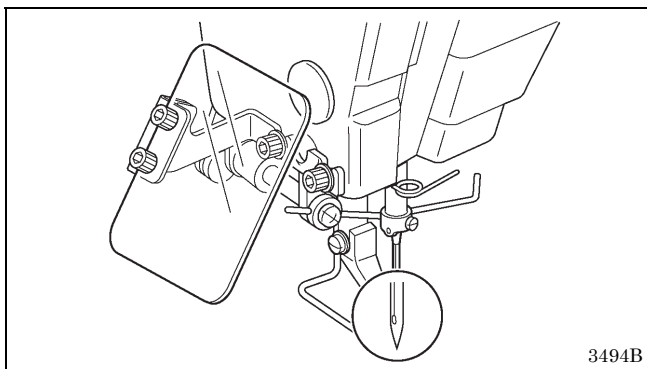

Always check that the tip of the needle is not broken and also that the needle is not bent before starting sewing.

6-7. Cleaning around the needle plate and rotary hook

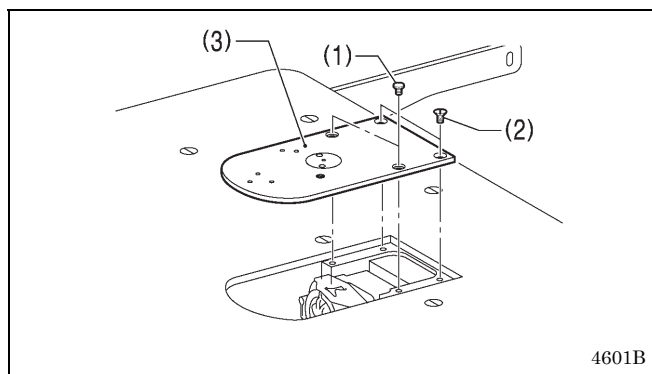

1. Remove the two screws (1) and the two pan screws (2), and then remove the needle plate (3).

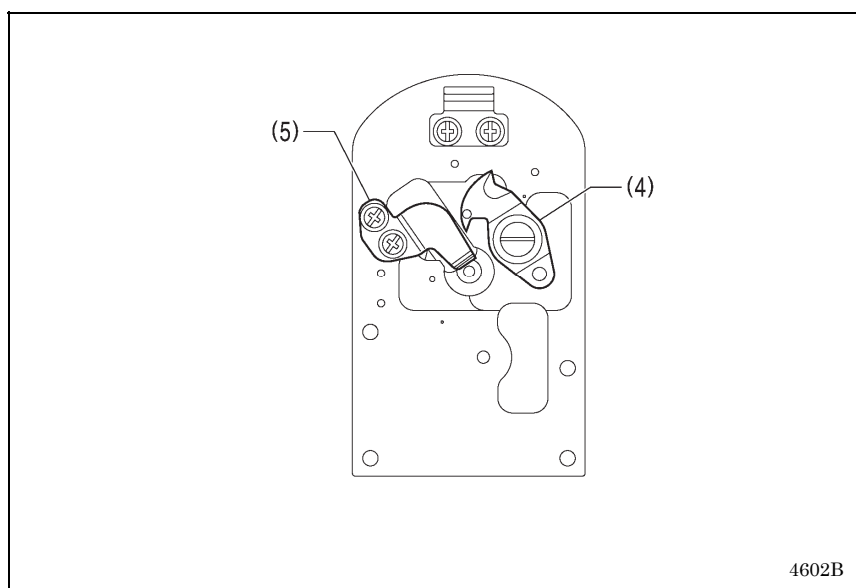

2. Clean away any the cotton scraps and thread scraps from the movable knife (4), the fixed knife (5) and the area around them.
3. Apply grease to the pin of the connecting plate, insert the connecting plate into the hole in the movable knife (4), and then install the needle plate (3).

6-8. Lubrication

Lubricate the sewing machine while referring to "3-19. Lubrication".

6-9. Applying grease

If the grease-up warnings [E100] or [E101] appear, apply grease to the needle bar bush.

! E100

It is time for grease up. Apply grease after turning off the power of the sewing machine. After that, operate the prescribed reset procedure. Please refer to the instruction manual for details. (Subcode = 0)



! E101

Grease up period has been approached. Apply grease after turning off the power of the sewing machine. After that, operate the prescribed reset procedure. To continue sewing without grease up, press Reset key. Please refer to the instruction manual for details. (Subcode = 1)



<Applying grease>

Use the Brother-specified "Grease unit (SB1275-201)".
Ask the place of purchase for details on obtaining this item.

1. Using the tube

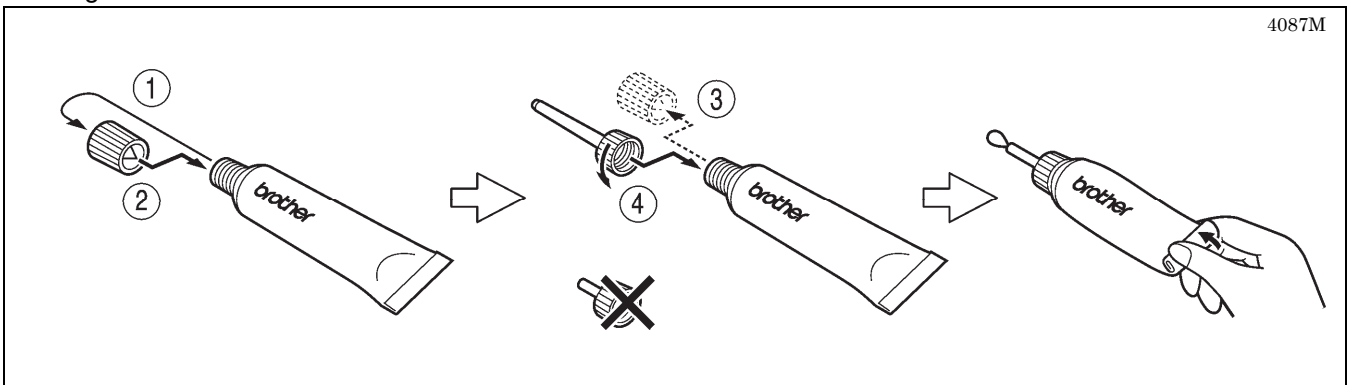

2. Removing the face plate

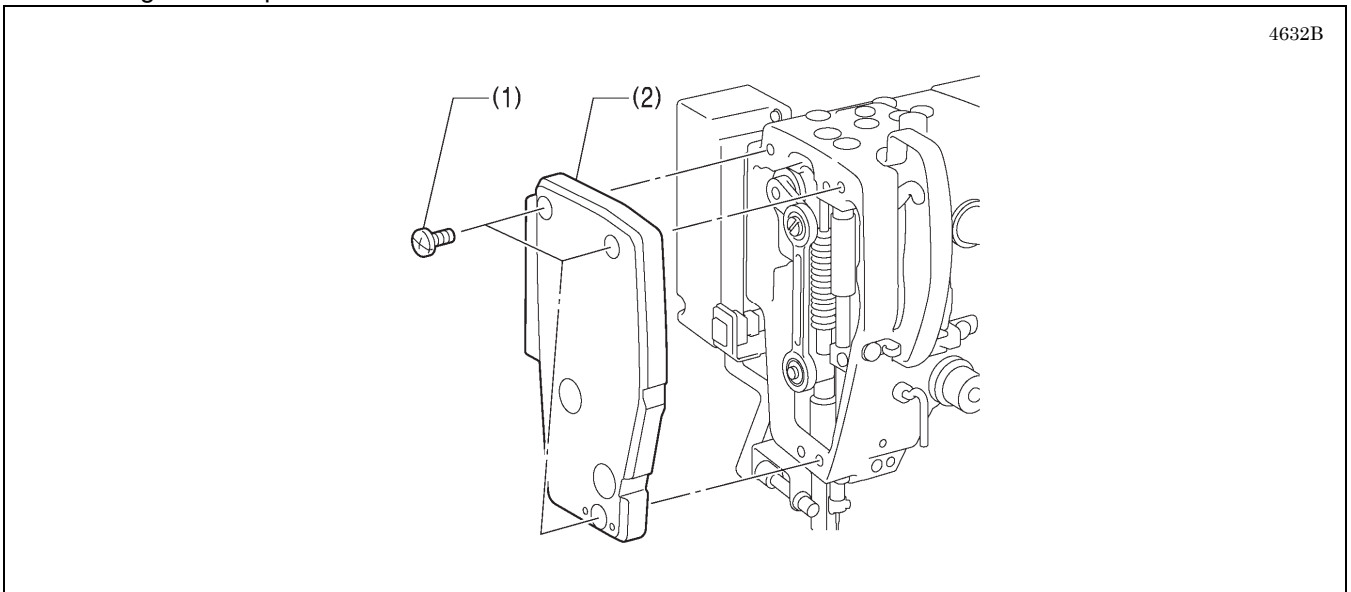

Remove the three screws (1), and then remove the face plate (2).

3. Applying grease

4633B

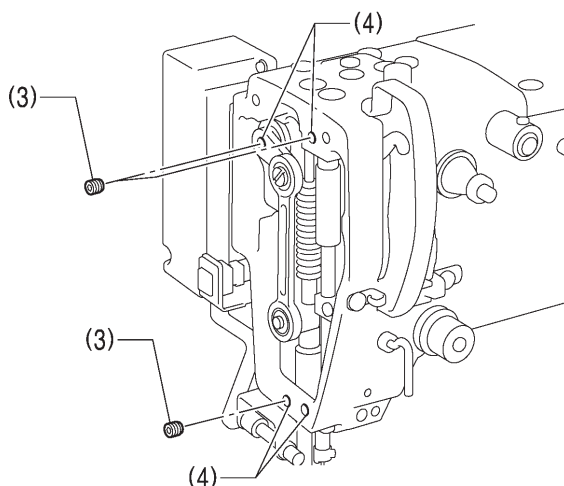

Remove the three set screws (3), and apply grease to the four holes (4).

When installing the set screws, gently tighten them to about 1 N.m. If the set screws are tightened too firmly, it may damage the sewing machine.

<Grease-up counter initialization method>

After applying grease, carry out the procedure given below to initialize the cumulative number of stitches up to when the grease was applied.

| | |
|----------|--|
| <p>1</p> | <p>Turn off the power for the sewing machine.</p> |
| <p>2</p> | <div style="display: flex; align-items: center;"> <div style="flex: 1;"> </div> <div style="flex: 1; padding-left: 10px;"> <p>While pressing the HOME key (4) and the ENTER key (6), turn on the power switch.</p> <p>Keep holding down the HOME key (4) and the ENTER key (6) until the home screen is displayed.</p> </div> </div> |
| <p>3</p> | <div style="display: flex; align-items: center;"> <div style="flex: 1;"> </div> <div style="flex: 1; padding-left: 10px;"> <p>When the screen shown at left appears, release the keys.</p> </div> </div> |

6. CLEANING

4

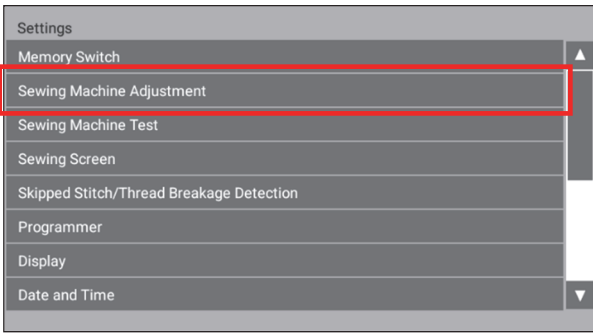

Settings
Memory Switch
Sewing Machine Adjustment
Sewing Machine Test
Sewing Screen
Skipped Stitch/Thread Breakage Detection
Programmer
Display
Date and Time

Touch Settings -> Sewing Machine Adjustment -> Grease up.

5

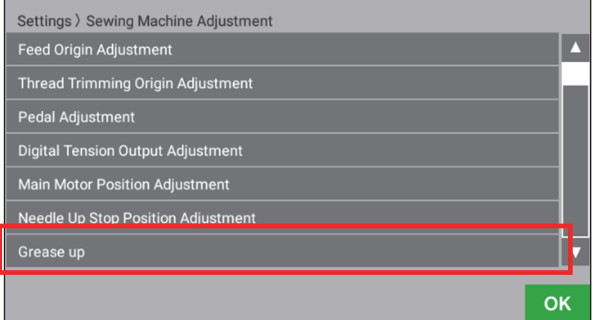

Settings > Sewing Machine Adjustment
Feed Origin Adjustment
Thread Trimming Origin Adjustment
Pedal Adjustment
Digital Tension Output Adjustment
Main Motor Position Adjustment
Needle Up Stop Position Adjustment
Grease up

OK

If you touch OK in the screen shown at left, the grease up counter will be initialized.

5

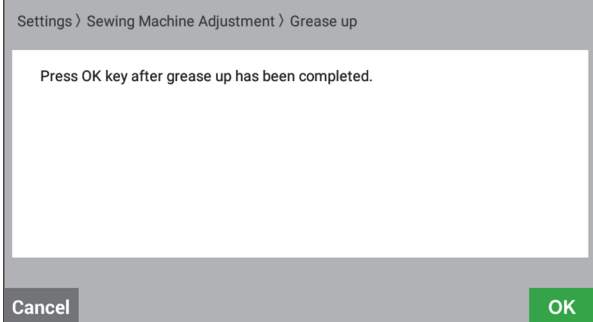

Settings > Sewing Machine Adjustment > Grease up

Press OK key after grease up has been completed.

Cancel OK

5

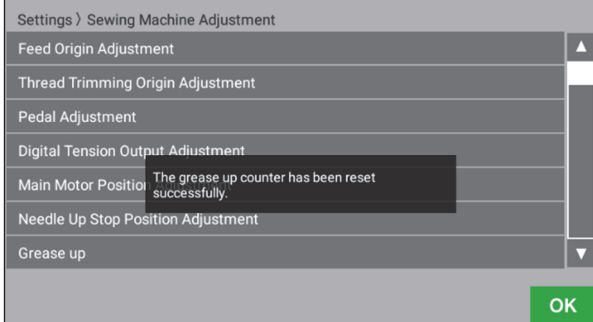

Settings > Sewing Machine Adjustment
Feed Origin Adjustment
Thread Trimming Origin Adjustment
Pedal Adjustment
Digital Tension Output Adjustment
Main Motor Position
Needle Up Stop Position Adjustment
Grease up

The grease up counter has been reset successfully.









OK

6

After the initialization is complete, turn off the power.

7. STANDARD ADJUSTMENTS

CAUTION

- | | |
|---|--|
| <p> Maintenance and inspection of the sewing machine should only be carried out by a qualified technician.</p> <p> Ask your Brother dealer or a qualified electrician to carry out any maintenance and inspection of the electrical system.</p> <p> Turn off the power switch and disconnect the power cord before carrying out the following operations. If the foot switch is depressed by mistake, the sewing machine might start operating and injury could result.</p> <ul style="list-style-type: none"> • Inspection, adjustment and maintenance • Replacing consumable parts such as the rotary hook <p> Disconnect the air hoses from the air supply and wait for the needle on the pressure gauge to drop to "0" before carrying out inspection, adjustment and repair of any parts which use the pneumatic equipment.</p> <p> If the power switch and air need to be left on when carrying out some adjustment, be extremely careful to observe all safety precautions.</p> | <p> Hold the machine head with both hands when tilting it back or returning it to its original position. In addition, do not subject the machine head to extra force while it is tilted back. If this is not observed, the machine head may become unbalanced and fall down, and serious injury or damage to the sewing machine may result.</p> <p> Be sure to wear protective goggles and gloves when handling the lubricating oil and grease, so that they do not get into your eyes or onto your skin. If the oil and grease get into your eyes or onto your skin, inflammation can result. Furthermore, do not drink or eat the lubricating oil or grease. They may cause diarrhea or vomiting. Keep the oil out of the reach of children.</p> <p> If any safety devices have been removed, be absolutely sure to re-install them to their original positions and check that they operate correctly before using the machine.</p> |
|---|--|

7-1. Thread take-up spring

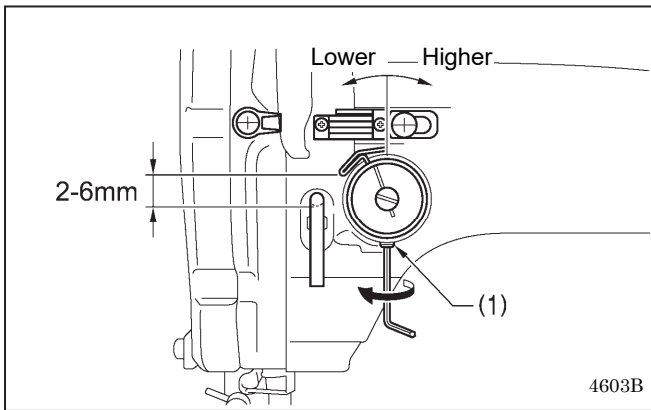

| | |
|-----------------------------------|-----------|
| Thread take-up spring height (mm) | 2 - 6 |
| Thread take-up spring tension (N) | 0.6 - 1.2 |

<Thread take-up spring height>

Loosen the set screw (1) and turn the adjuster to adjust.

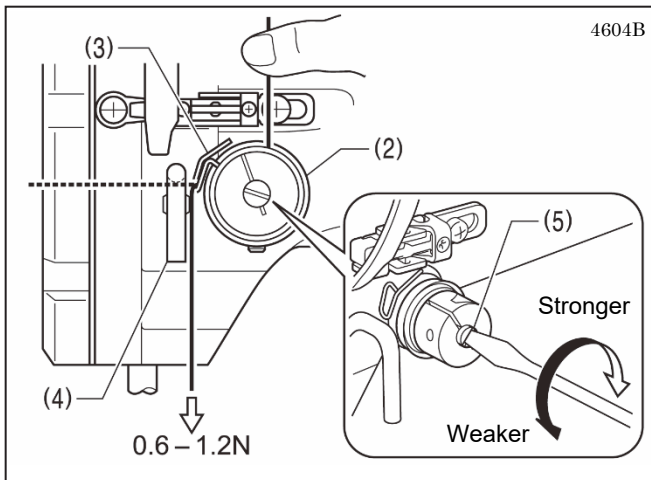

<Thread take-up spring tension>

1. Press the upper thread slightly above the tension bracket (2) with a finger to stop the thread spooling out.
2. Pull the upper thread downward so that the thread take-up spring (3) is extended to the same height as the base of the thread guide arm (4), and then measure the tension of the thread take-up spring (3).
3. Use a screwdriver to turn the tension stud (5) in order to adjust the tension of the thread take-up spring (3).

NOTE:

If the thread tension spring (3) is not adjusted correctly, the upper thread trailing length will be uneven after thread trimming.

7-2. Adjusting the skipped stitch and thread breakage detector position

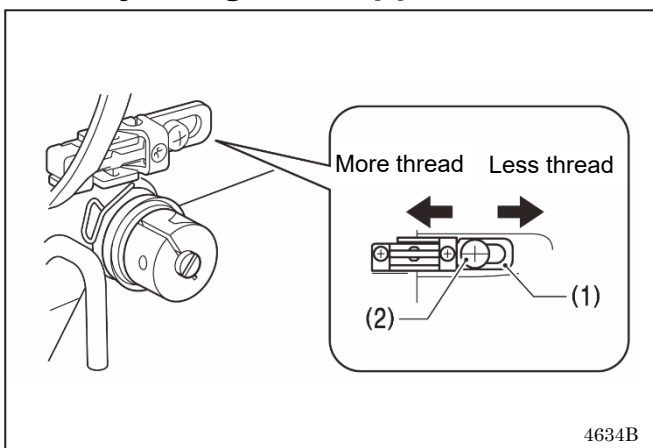

To adjust the position, loosen the screw (2) and then move the skipped stitch and thread breakage detector (1).

- When sewing heavy-weight material, move the skipped stitch and thread breakage detector (1) to the left. (The thread take-up amount will increase.)
- When sewing light-weight material, move the skipped stitch and thread breakage detector (1) to the right. (The thread take-up amount will decrease.)

7-3. Adjusting the needle bar height

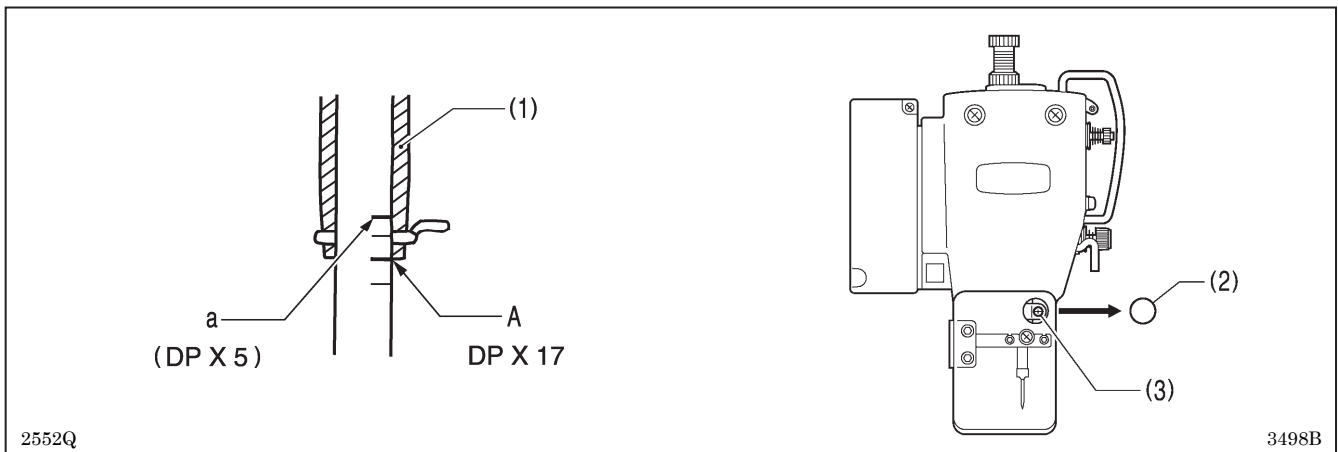

Turn the pulley in the direction of the arrow to move the needle bar to the lowest position. Then remove the rubber plug (2), loosen the screw (3) and then move the needle bar up or down to adjust so that the second reference line from the bottom of the needle bar (reference line A) is aligned with the lower edge of the needle bar bush (1).

* If using a DP X 5 needle, align with the highest reference line (reference line a).

7-4. Adjusting the needle and rotary hook timing

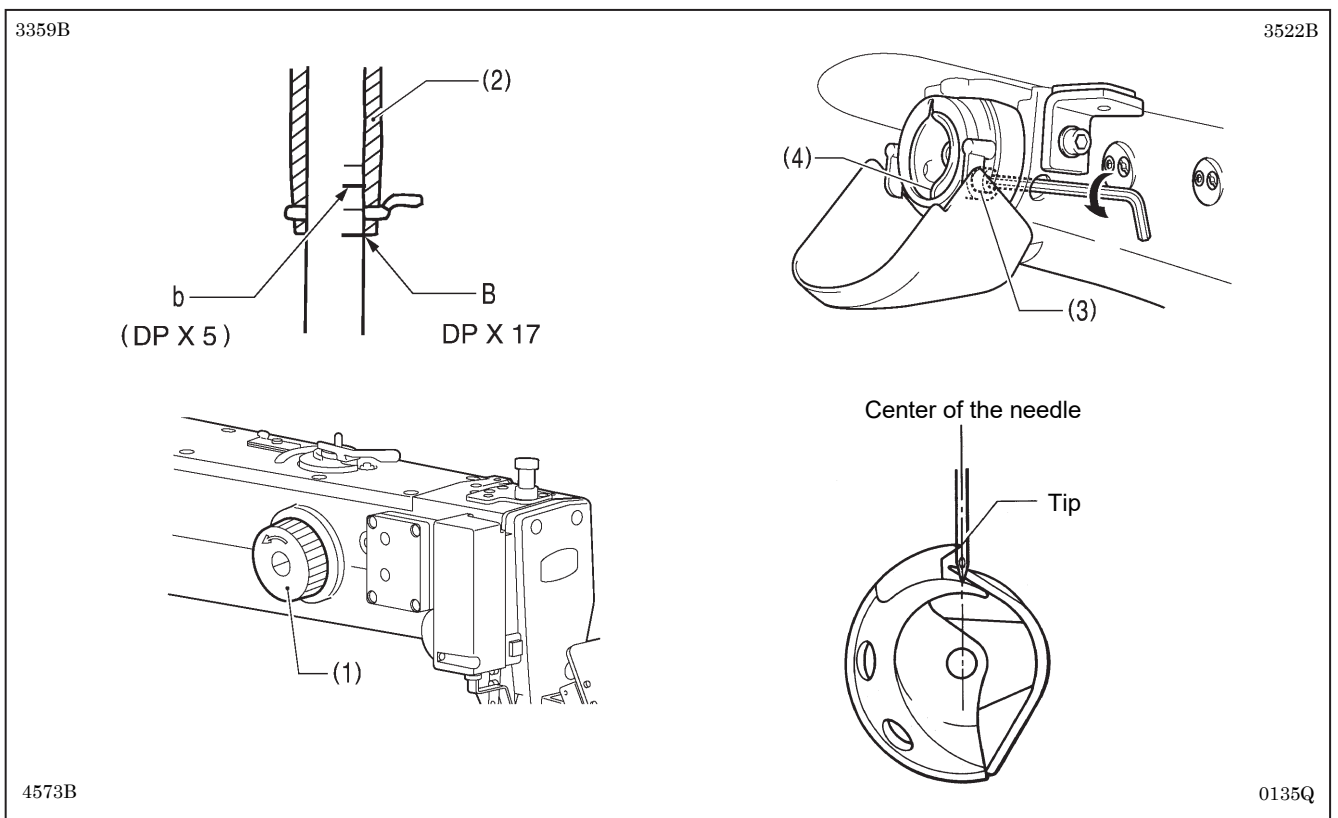

1. Turn the pulley (1) in the direction of the arrow to raise the needle bar from the lowest position until the lowest reference line on the needle bar (reference line B) is aligned with the lower edge of the needle bar bush (2).
* If using a DP X 5 needle, align with the reference line b which is the second reference line from the top.
2. Loosen the bolt (3).
3. Move the driver (4) sideways so that the tip of the rotary hook is aligned with the middle of the needle, and then tighten the bolt (3).

7-5. Adjusting the driver (needle guard) position

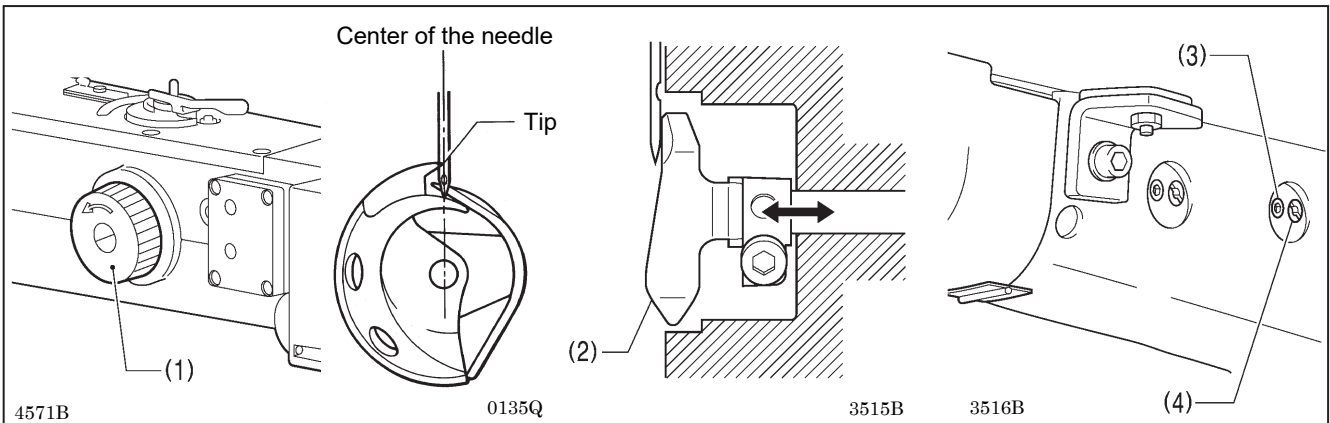

Turn the pulley (1) in the direction of the arrow to align the tip of the rotary hook with the center of the needle, and then loosen the set screw (3) and turn the adjusting stud (4) to adjust so that the driver (2) is touching the needle.

NOTE:

If the driver (2) crosses the needle more than necessary, it will cause problems with the thread tension. Furthermore, if it does not cross the needle at all, the tip of the rotary hook will interfere with the needle and skipped stitches may occur.

7-6. Adjusting the clearance between the needle and rotary hook tip

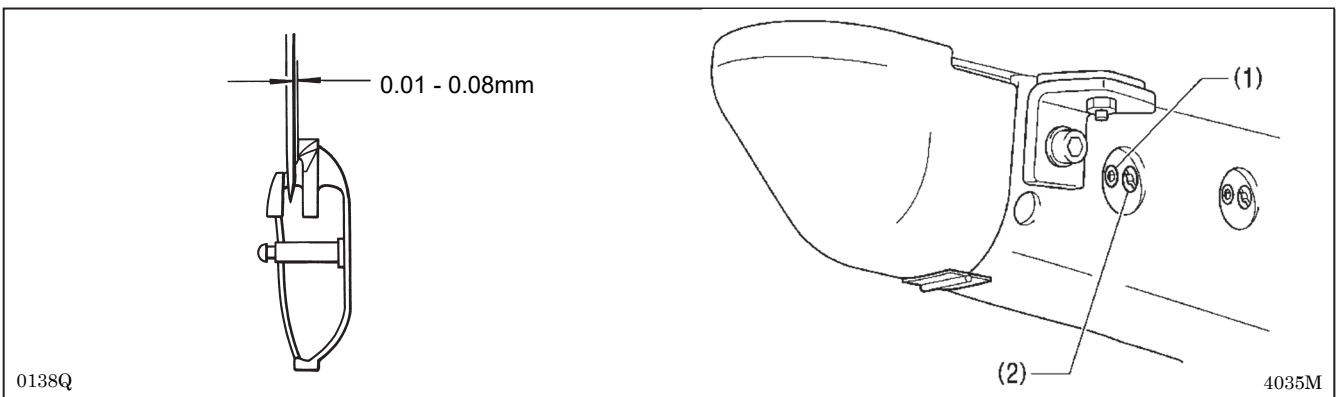

Turn the pulley in the direction of the arrow to align the tip of the rotary hook with the center of the needle, and then loosen the set screw (1) and turn the adjusting stud (2) to adjust so that the clearance between the needle and the tip of the rotary hook is 0.01 to 0.08 mm.

7-7. Adjusting the shuttle race thread guide

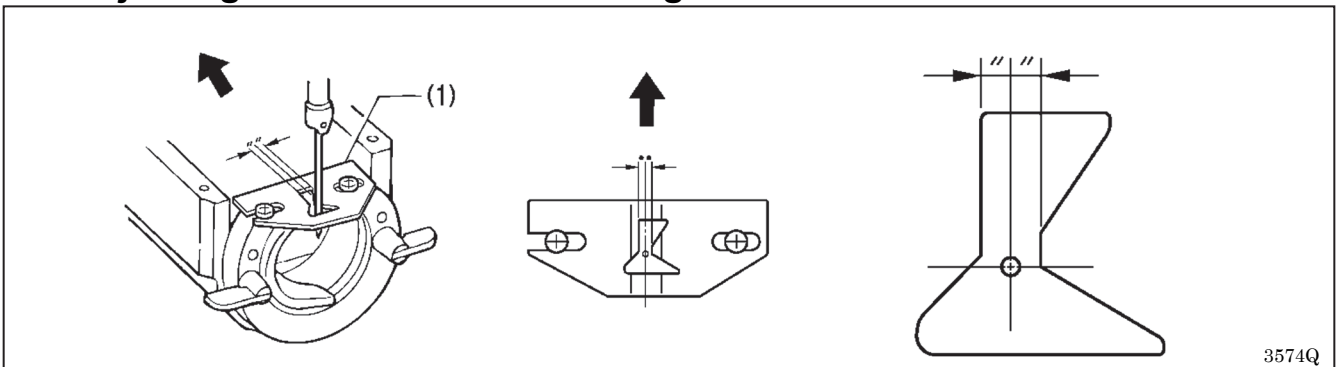

Install the shuttle race thread guide (1) by pushing it in the direction of the arrow so that the needle groove is aligned with the center of the needle plate hole.

NOTE:

If the shuttle race thread guide (1) is in the wrong position, thread breakages, soiled thread or tangling of the thread may occur. The position of the shuttle race thread guide (1) is adjusted at the time of shipment from the factory. It should not be changed if possible.

7-8. Rotary hook lubrication amount

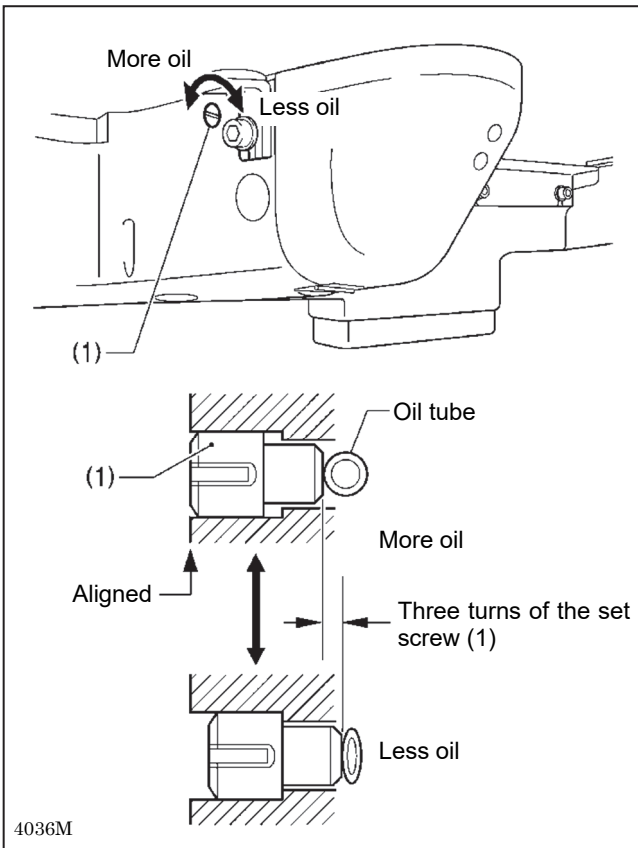

<Adjusting by changing the pressure on the oil tube>

The optimum position is when the head of the set screw (1) is aligned with the edge of the bed. The rotary hook lubrication amount can be adjusted within three turns to the right from that position.

- If the set screw (1) is turned clockwise, the lubrication amount becomes smaller.
- If the set screw (1) is turned counterclockwise, the lubrication amount becomes greater.

* If you would like the lubrication amount to be increased further from the position the head of the set screw (1) is aligned with the edge of the bed, use the following method to make the adjustment.

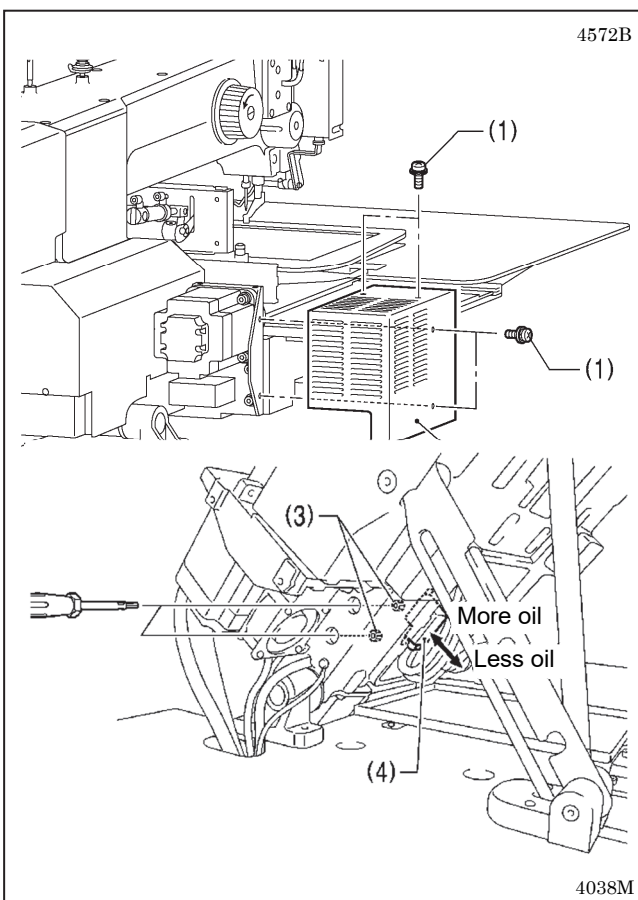

<Adjusting by changing the amount of oil supplied from the sub-tank>

1. Remove the four screws (1), and then remove the X motor cover (2).
2. Tilt back the machine head.
3. Insert a screwdriver into the holes in the left side of the sewing machine bed and loosen the two bolts (3)
4. Move the sub-tank (4) up or down to adjust its position, and then tighten the two bolts (3).
 - If the position of the sub-tank (4) is raised, the lubrication amount will increase.
 - If the position of the sub-tank (4) is lowered, the lubrication amount will decrease.
5. Return the machine head to its original position.
6. Install the X motor cover (2) with the four screws (1).

7-9. Adjusting the thread trimming home position at the sewing end

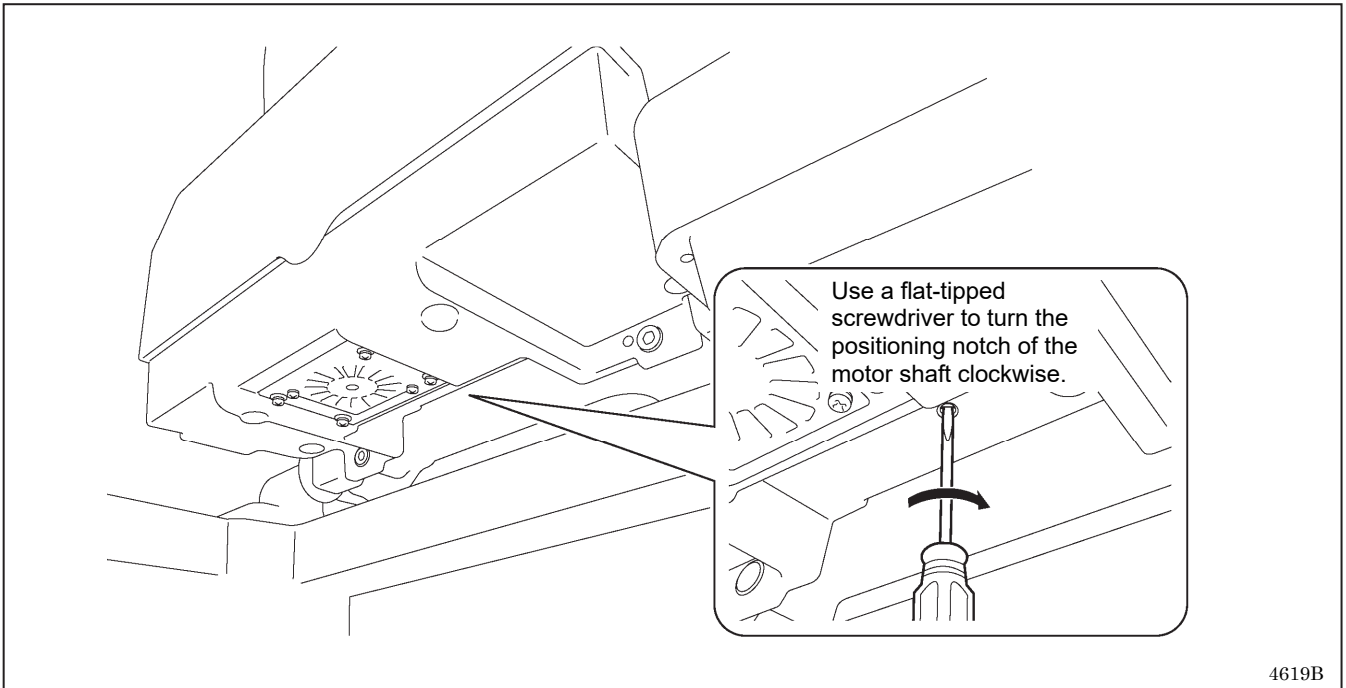

1. Insert a flat-tipped screwdriver through the hole under the bed shown in the diagram to turn the shaft of the thread trimmer motor clockwise until it stops.

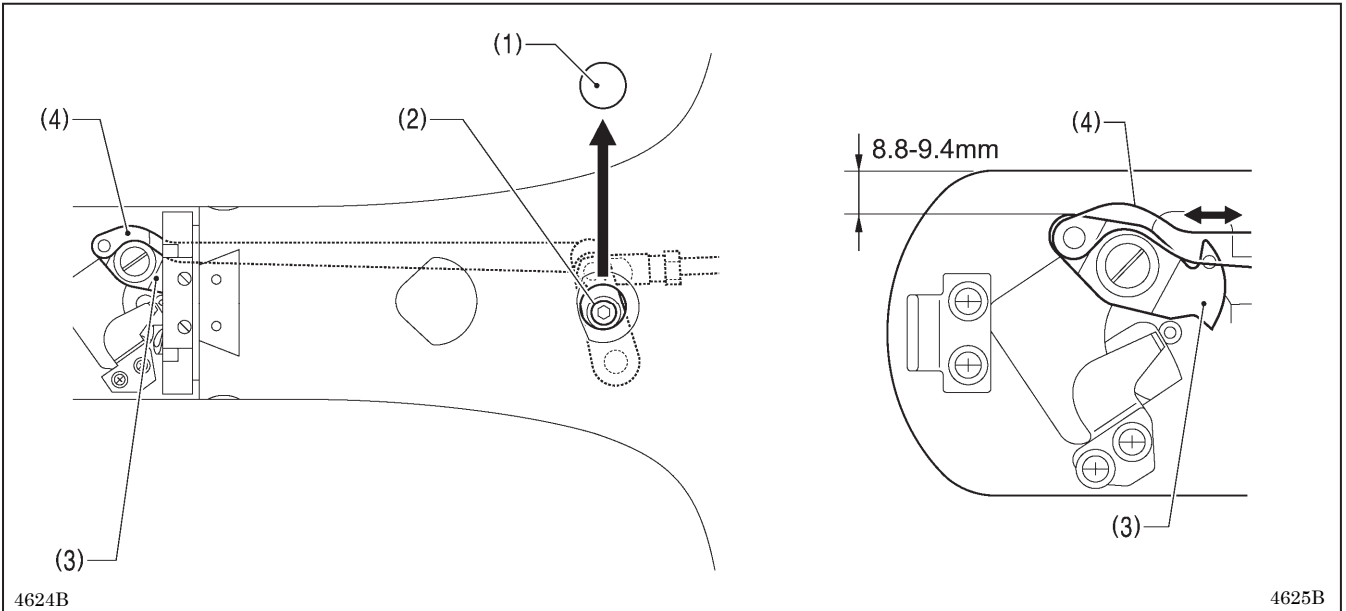

2. Remove the rubber cap (1).
3. Loosen the socket bolt (2).
4. Move the movable knife connecting plate (4) back and forth to adjust so that the distance from the ridge on the right side of the needle plate to the ridge on the movable knife (3) is 8.8 to 9.4 mm.
5. Loosen the socket bolt (2), and then check the above position once more.

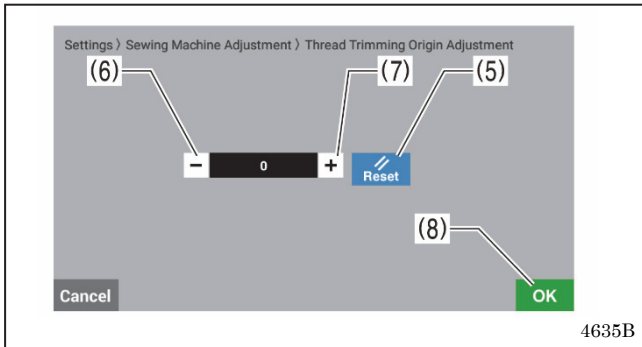

6. Select "Thread Trimming Home Position Adjustment" in sewing machine adjustment mode.
7. First press Reset (5), and then press "-" (6) five times and "+" (7) several times until the movable knife moves to its maximum plunge position. (The sound of the motor will change and the movable knife will stop moving.)
8. At that position, press Reset (5). * The current position will then be set as the maximum plunge position for the movable knife.
9. Press OK (8) to complete the setting.

7-11. Replacing the movable and fixed knives

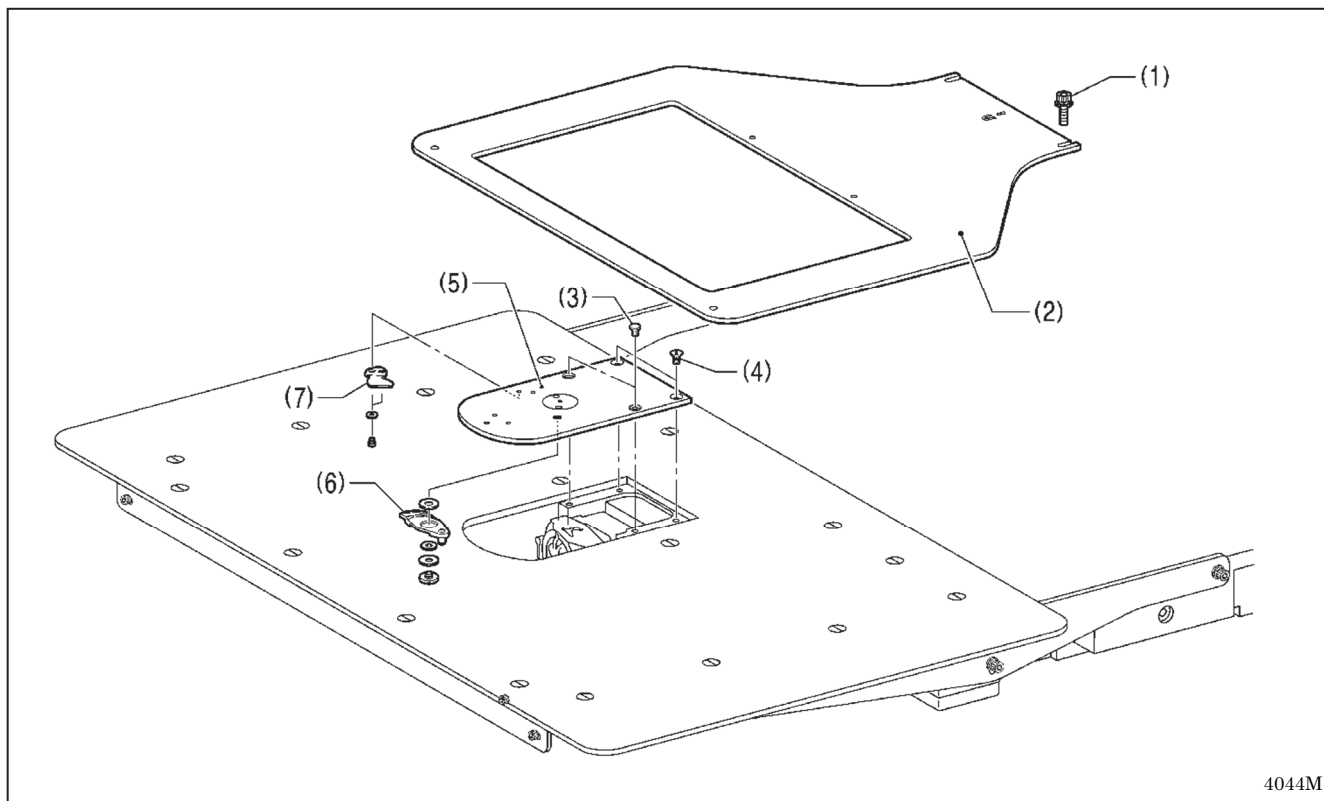

4044M

1. Loosen the two bolts (1) and then remove the feed plate (2).
2. Open the shuttle race cover, remove the two screws (3) and the two flat screws (4), and then remove the needle plate (5).
3. Remove the movable knife (6) and the fixed knife (7).

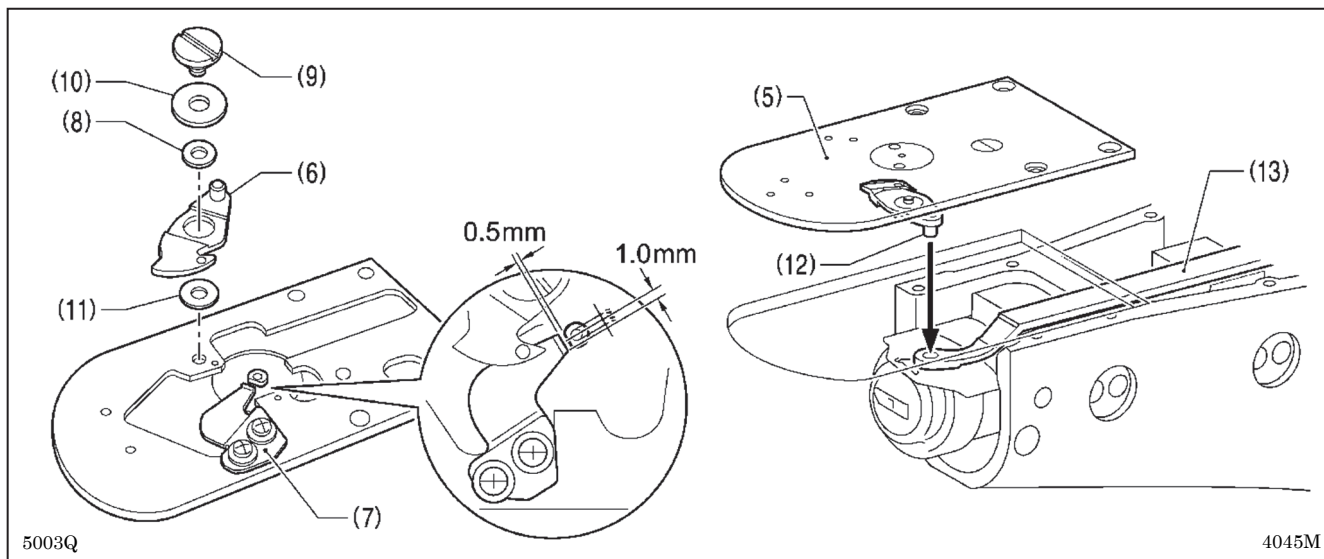

5003Q

4045M

4. Install the new fixed knife (7) in the position shown in the illustration.
5. Apply grease to the outside of the collar (8) and to the shoulder screw (9), and then install the new movable knife (6) together with the thrust washer (10) and the movable knife spacer (11).
6. Check that the movable knife (6) and fixed knife (7) cut the thread cleanly. Replace the movable knife spacer with accessory spacers ($t=0.2, 0.3, 0.4$) so that the knives trim the thread accurately.
 - * If the knife pressure is too weak and the thread is not completely cut, use a thinner movable knife spacer.
 - * If the knife pressure is too strong and the movable knife (1) turns stiffly, use a thicker movable knife spacer.
7. Apply grease to the pin (12), place it into the movable knife connecting plate (13), and install it to the needle plate (5).
8. Check that the needle is aligned with the center of the needle hole.
9. Install the feed plate (2). (Refer to the next page.)

7-12 Feed plate installation method

CAUTION



Machine installation should only be carried out by a qualified technician.

Be careful to avoid injury from moving parts.

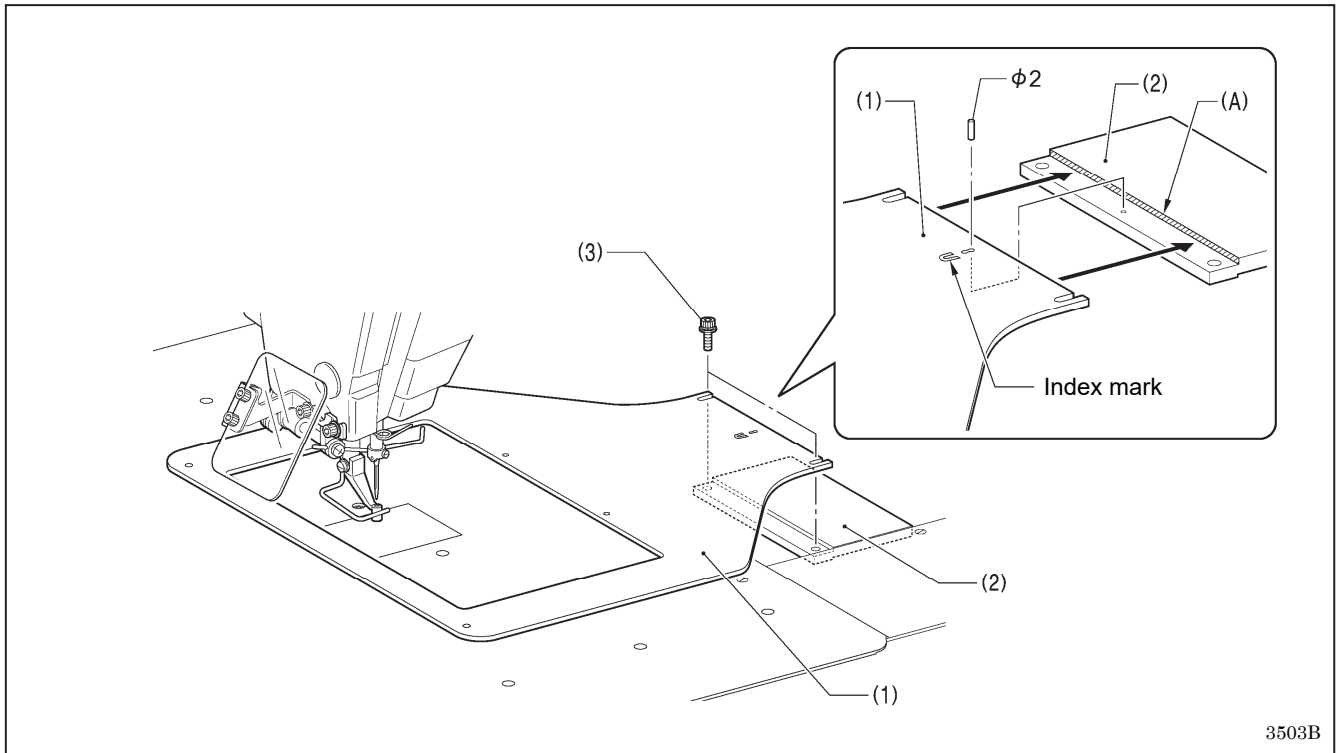

3503B

NOTE:

Install the feed plate (1) so that the surface with the index mark is at the top.

Place the rear edge of the feed plate (1) against the stepped part (A) of the Y base plate (2) and use a 2 mm diameter pin (such as a DP needle) to align the hole in the feed plate (1) with the hole in the Y base plate (2); then tighten the two socket bolts (3).

7-13. Adjusting the thread wiper

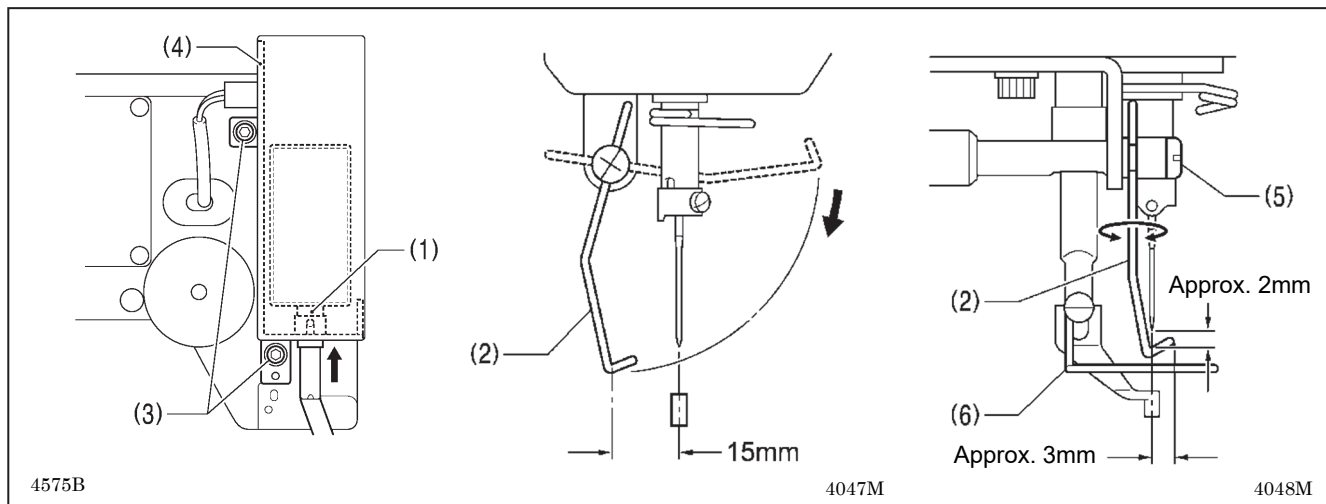

1. Loosen the two screws (3) and shift the entire solenoid setting plate (4) up or down to adjust so that the thread wiper (2) is 15 mm in front of the needle center when the plunger (1) of the thread wiper solenoid is driven to the full stroke.
2. Loosen the screw (5) and adjust the position of the thread wiper (2) so that the distance from the thread wiper to the tip of the needle is approximately 2 mm and the tip of the thread wiper (2) is approximately 3 mm from the center of the needle when the thread wiper (2) passes below the needle during operation.

NOTE:

Check that the thread wiper (2) does not touch the finger guard (6).

7-14. Intermittent presser foot installation position

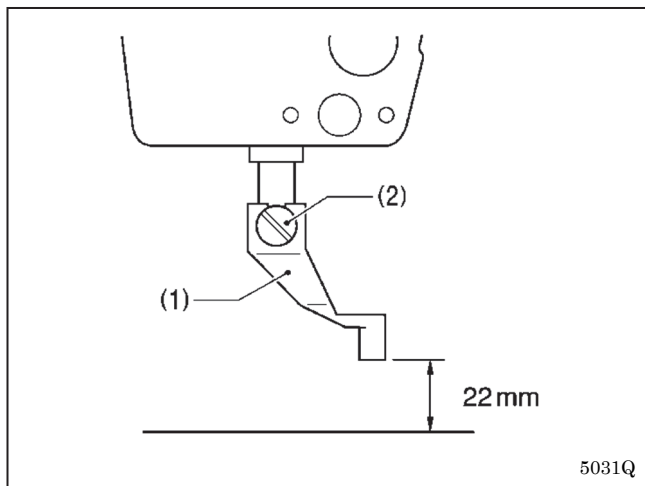

Install the intermittent presser foot (1) with the screw (2) so that the distance from the bottom of the intermittent presser foot (1) to the top of the needle plate is 22 mm when the sewing machine is stopped and the intermittent presser foot (1) is raised.

7-15. Adjusting the work clamp lift amount

The maximum lift amount for the work clamp (2) is 30 mm above the top of the needle plate.

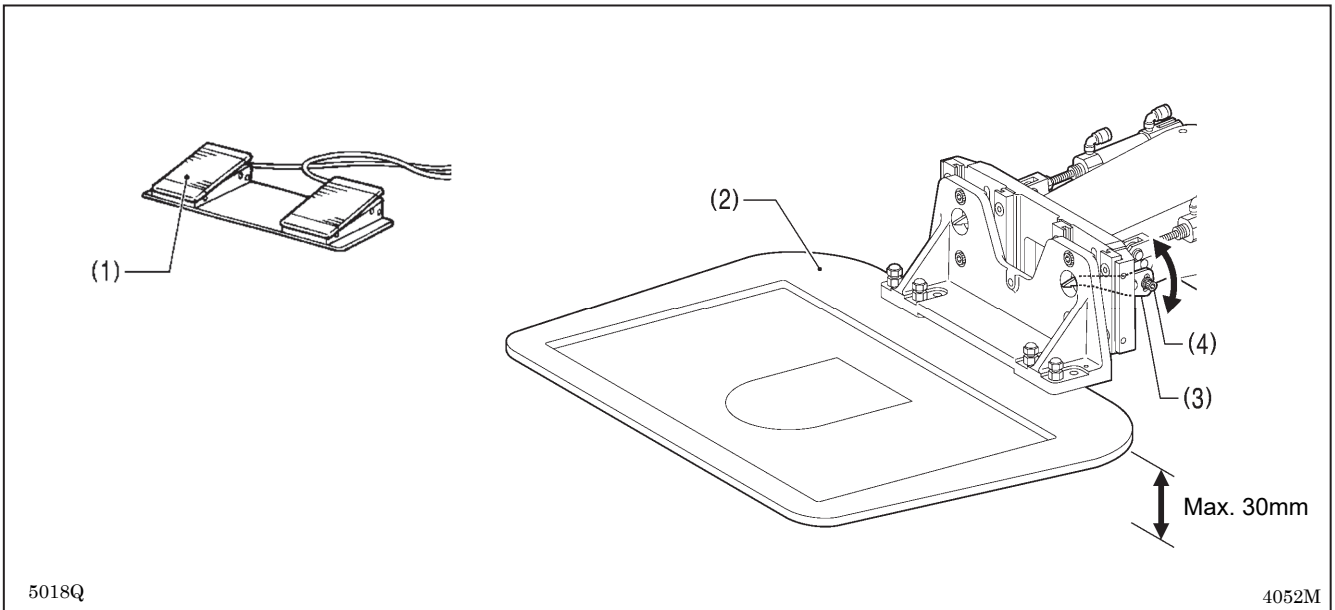

1. Turn on the air, and then depress the work clamp switch (1) to raise the work clamp (2).
2. Loosen the two bolts (4) of the work clamp lifter lever (3), and move the work clamp lifter lever (3) up or down to adjust.

7-16. Adjusting the air pressure

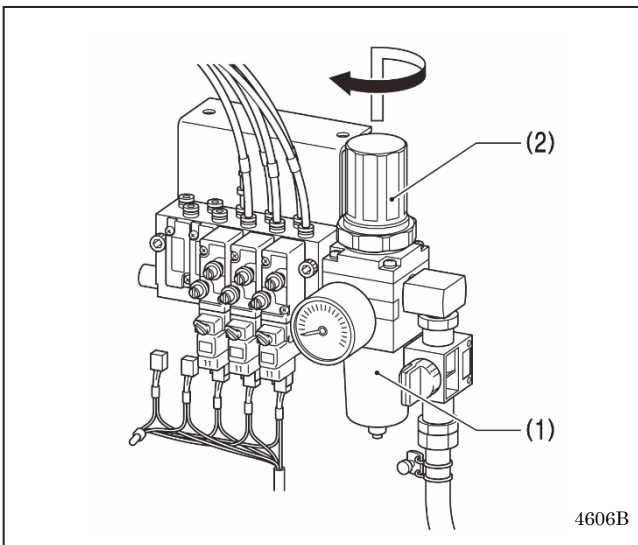

Lift up the handle (2) of the regulator (1) and then turn it to adjust the air pressure to 0.5 MPa. After adjustment is complete, push the handle (2) downward to lock it.

7-17. Adjusting the speed controller

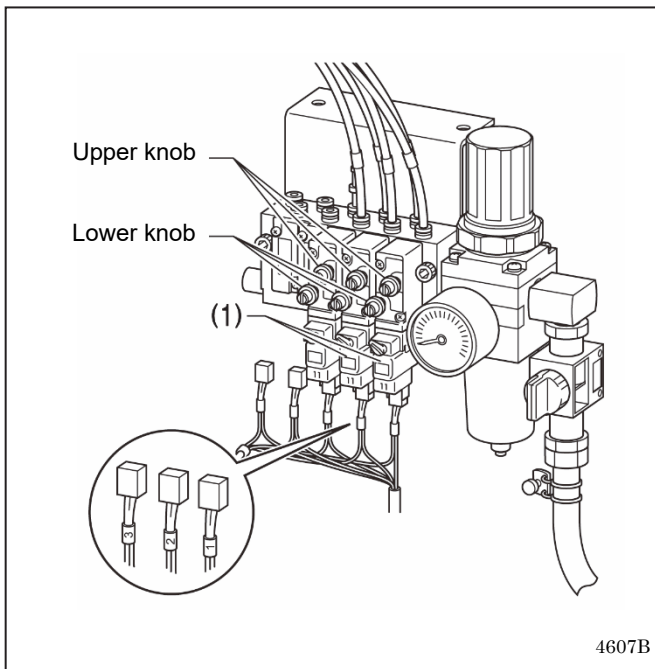

You can adjust the lifting and lowering speeds for the work clamp using the knobs on the valves.

- When the upper knob is tightened, the lifting speed becomes slower. When it is loosened, the lifting speed becomes faster.
- When the lower knob is tightened, the lowering speed becomes slower. When it is loosened, the lowering speed becomes faster.

Reference adjustments

| | |
|------------|--|
| Upper knob | Fully tighten and then loosen by 5 turns |
| Lower knob | Fully tighten and then loosen by 8 turns |

You can operate the work clamp when the power is turned off by pressing the manual buttons (1).

7-18. If processing the work clamp to a shape that matches the sewing pattern

Use the work clamps and feed plate which match the sewing pattern, while referring to the processing diagram below.

* Values in () are the recommended sizes when sewing using the maximum area (BAS-341JX: 250x160 mm, BAS-342JX: 300x200 mm).

BAS-341JX

<Work clamp processing diagram>

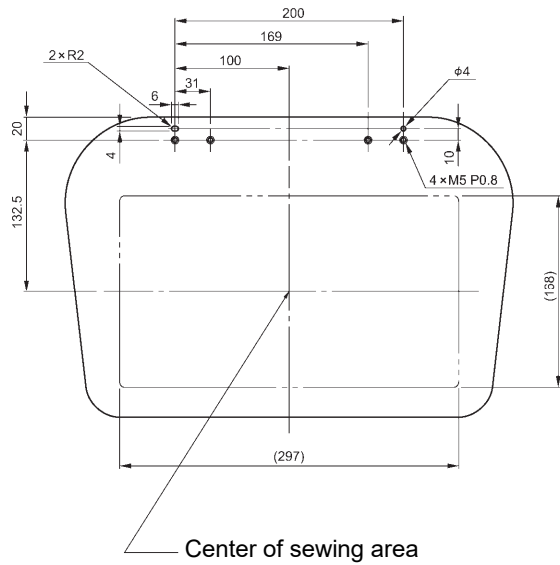

3523B

<Feed plate processing diagram>

Recommended thickness: 1.5 mm

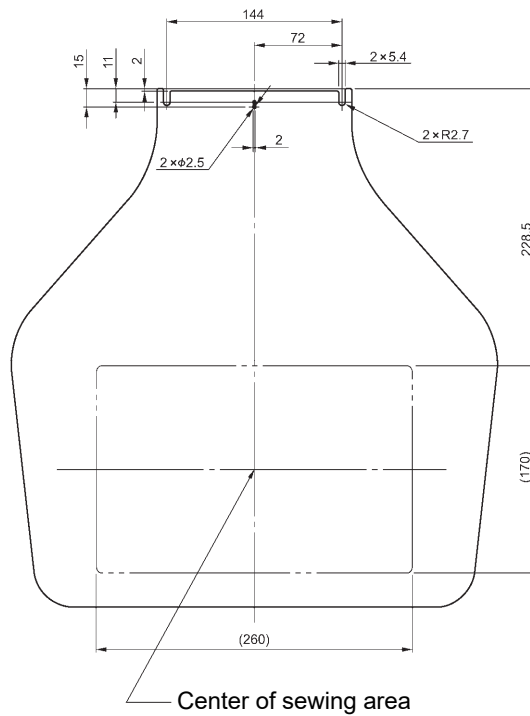

[mm]

3524B

BAS-342JX

<Work clamp processing diagram>

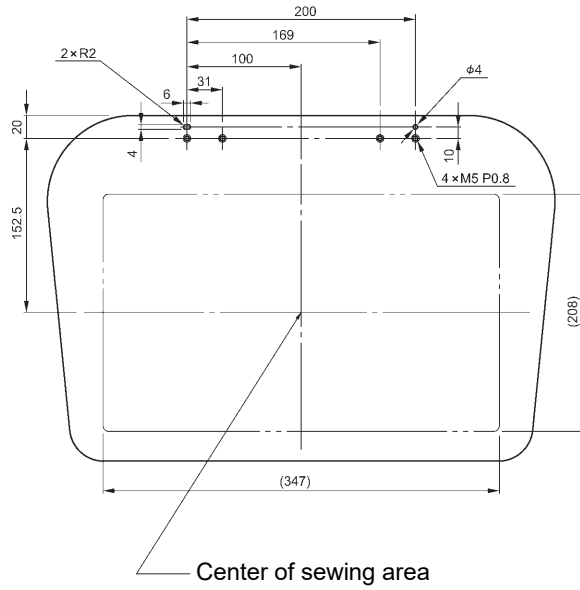

3525B

<Feed plate processing diagram>

Recommended thickness: 1.5 mm

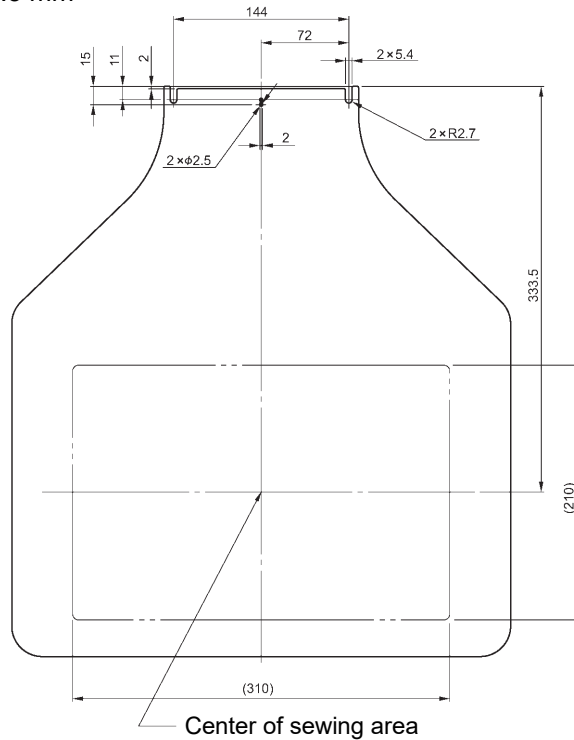

[mm]

3526B

8. LIST OF ERROR CODES





DANGER



Wait at least 5 minutes after turning off the power switch and disconnecting the power cord from the wall outlet before opening the control box cover. Touching areas where high voltages are present can result in severe injury.

If a malfunction occurs with the sewing machine, a buzzer will sound and an error code will appear on the screen. Follow the remedy procedure to eliminate the cause of the problem.

Switch-related errors

| Code | Cause of error and remedy |
|------|--|
| E010 | The STOP switch was pressed. Press the RESET key to clear the error. |
| E011 | The STOP switch was pressed. Press the RESET key to clear the error. You can touch the     keys on the LCD panel to move the feed in order to continue sewing. |
| E012 | The STOP switch was pressed. Press the RESET key to clear the error, and then depress the start switch to move the feed mechanism to the home position. |
| E015 | The stop switch was still being pressed when the power was turned on, or there is a problem with the stop switch connection. Turn off the power, and then check that connector P9 on the main P.C. board is properly connected. |
| E016 | Problem with the stop switch connection. Turn off the power, and then check that connector P9 on the main P.C. board is properly connected. |
| E017 | The STOP switch was pressed. Turn off the power, and then turn it back on again. |
| E020 | The start switch was pressed without the work clamp being lowered. First lower the work clamp. |
| E025 | Start switch was being depressed when power was turned on. Release the switch. |
| E035 | Work clamp switch was being depressed when power was turned on. Release the switch. |
| E050 | Machine head tilting was detected after the power was turned on. Turn off the power, and then return the machine head to its original position. Check that connector P14 on the main P.C. board is properly connected. |
| E051 | Machine head tilting was detected while the sewing machine was operating. Turn off the power, and then check that connector P14 on the main P.C. board is properly connected. |
| E055 | Machine head tilting was detected when the power was turned on. Turn off the power, and then return the machine head to its original position. Check that connector P14 on the main P.C. board is properly connected. |
| E064 | Touch panel was being touched when power was turned on. Turn off the power, and then turn it back on again. |
| E065 | A key on the LCD panel was still being pressed when the power was turned on, or key is faulty. Turn off the power, and then turn it back on again. |

8. LIST OF ERROR CODES

Motor-related errors

| Code | Cause of error and remedy |
|-------------|--|
| E100 | It is time for grease up. Apply grease after turning off the power of the sewing machine. After that, operate the prescribed reset procedure. Please refer to the instruction manual for details. |
| E101 | Grease up period has been approached. Apply grease after turning off the power of the sewing machine. After that, operate the prescribed reset procedure. To continue sewing without grease up, press Reset key. Please refer to the instruction manual for details. |
| E110 | The needle bar is not stopped in the needle up stop position. Turn the pulley until the point where the error display disappears. |
| E111 | Upper shaft did not stop at the needle up stop position when the sewing machine stopped. Turn off the power, and then check that connectors P11 and P1 on the motor P.C. board and connector P6 on the main P.C. board are properly inserted. |
| E121 | Thread trimming was not completed. Turn off the power, and then check if the cutting edges of the fixed knife and movable knife are damaged or worn. |
| E130 | Upper shaft motor stopped due to a problem, or synchronizer is faulty. Turn off the power, and then turn the pulley and check if the sewing machine has locked up. Check that connectors P11 and P1 on the motor P.C. board, connector P6 on the main P.C. board and the 4-pin connector of the upper shaft motor on the motor P.C. board |
| E131 | Synchronizer is not connected correctly. Turn off the power, and then check that connector P11 on the motor P.C. board is properly connected. |
| E132 | Problem detected with upper shaft motor operation. Turn off the power, and then check that connectors P11 and P1 on the motor P.C. board, connector P6 on the main P.C. board and the 4-pin connector of the upper shaft motor on the motor P.C. board are properly inserted. |
| E133 | Upper shaft motor stopping position is incorrect. Turn off the power, and then check that connectors P11 and P1 on the motor P.C. board, connector P6 on the main P.C. board and the 4-pin connector of the upper shaft motor on the motor P.C. board are properly inserted. |
| E150 | Upper shaft motor is overheating, or temperature sensor is faulty. Turn off the power, and then check the upper shaft motor. (When sewing data with a small number of stitches (15 stitches or less) is sewn repeatedly (short cycle operation), the upper shaft motor may overheat and the "E150" error code may be generated.) |

Feed mechanism-related errors

| Code | Cause of error and remedy |
|-------------|--|
| E200 | X-feed motor home position cannot be detected. Problem with X-feed motor or poor X home position sensor connection. Turn off the power, and then check that connectors P17, P21 and P8 on the main P.C. board are properly connected. |
| E201 | X-feed motor stopped due to a problem. Turn off the power, and then check if there are any problems in the X-feed direction. Turn off the power, and then check that connectors P17 and P21 on the main P.C. board are properly connected. |
| E204 | X-feed motor stopped due to a problem during sewing. Turn off the power, and then check if there are any problems in the X-feed direction. Turn off the power, and then check that connectors P17 and P21 on the main P.C. board are properly connected. |
| E205 | X-feed motor stopped due to a problem while moving to the sewing start position. Turn off the power, and then check if there are any problems in the X-feed direction. Turn off the power, and then check that connectors P17 and P21 on the main P.C. board are properly connected. |
| E206 | X-feed motor stopped due to a problem during test feeding. Turn off the power, and then check if there are any problems in the X-feed direction. Turn off the power, and then check that connectors P17 and P21 on the main P.C. board are properly connected. |
| E210 | Y-feed motor home position cannot be detected. Problem with Y-feed motor or poor Y home position sensor connection. Turn off the power, and then check that connectors P18, P22 and P8 on the main P.C. board are properly connected. |

| Code | Cause of error and remedy |
|-------------|--|
| E211 | Y-feed motor stopped due to a problem. Turn off the power, and then check if there are any problems in the Y-feed direction. Turn off the power, and then check that connectors P18 and P22 on the main P.C. board are properly connected. |
| E214 | Y-feed motor stopped due to a problem during sewing. Turn off the power, and then check if there are any problems in the Y-feed direction. Turn off the power, and then check that connectors P18 and P22 on the main P.C. board are properly connected. |
| E215 | Y-feed motor stopped due to a problem while moving to the sewing start position. Turn off the power, and then check if there are any problems in the Y-feed direction. Turn off the power, and then check that connectors P18 and P22 on the main P.C. board are properly connected. |
| E216 | Y-feed motor stopped due to a problem during test feeding. Turn off the power, and then check if there are any problems in the Y-feed direction. Turn off the power, and then check that connectors P18 and P22 on the main P.C. board are properly connected. |
| E230 | Feed motor stopped due to a problem. Reduce the sewing speed or change the operation settings to the settings for heavy-weight materials. Ask the place of purchase for details on the setting method. |

Work clamp-related errors

| Code | Cause of error and remedy |
|-------------|---|
| E300 | Work clamp home position cannot be detected. Problem with work clamp motor or poor work clamp encoder connection. Turn off the power, and then check that connectors P19 and P23 on the main P.C. board are properly connected. |
| E301 | Work clamp raised or lowered position cannot be detected. Turn off the power, and then check if there are any problems in the work clamp vertical direction. Turn off the power, and then check that connectors P19 and P23 on the main P.C. board are properly connected. |
| E390 | The thickness is out of setting range of thickness detect code. Press the Reset key to clear the error. And then confirm that the material is set properly. Measurement result: **.** mm The setting range of thickness detect code: **.** mm - **.** mm |
| E391 | Thickness detection code has been reached without obtaining reference height. Press the Reset key to clear the error, and then depress the start switch to move the feed mechanism to the home position. If the error occurs again, check the sewing data. |
| E392 | The setting range of thickness detection exceeds the maximum presser foot height. Press the Reset key to clear the error, and then check the reference height and settings of thickness detection code. |
| E393 | Thickness exceeds the maximum presser foot height. Press the Reset key to clear the error. And then confirm that the material is set properly. |
| E394 | Thickness exceeds the maximum presser foot height. Press the Reset key to clear the error. And then confirm that the material is set properly. |

Communication and memory-related errors

| Code | Cause of error and remedy |
|-------------|---|
| E400 | Communication error detected between the main P.C. board and the panel P.C. board when the power was turned on. Turn off the power, and then check that connector P10 on the programmer main P.C. board inside the LCD panel and the connector P32 on the main P.C. board are properly connected. |
| E401 | Communication error detected between the main P.C. board and the motor P.C. board when the power was turned on. Turn off the power, and then check that connector P10 on the programmer main P.C. board inside the LCD panel and the connector P32 on the main P.C. board are properly connected. |
| E410 | Communication error detected between the main P.C. board and the panel P.C. board. Turn off the power, and then turn it back on again. Turn off the power, and then check that connector P10 on the programmer main P.C. board inside the LCD panel and the connector P32 on the main P.C. board are properly connected. |

8. LIST OF ERROR CODES

| Code | Cause of error and remedy |
|------|---|
| E411 | Communication error detected between the main P.C. board and the motor P.C. board. Turn off the power, and then turn it back on again. Turn off the power, and then check that connector P10 on the programmer main P.C. board inside the LCD panel and the connector P32 on the main P.C. board are properly connected. |
| E415 | Communication error detected between the panel and the skipped stitch/thread breakage detection device. Please check connection between panel and skipped stitch/thread breakage detection device, after that please restart the sewing machine. |
| E416 | Communication error detected between the panel and the skipped stitch/thread breakage detection device. Press the Reset key to clear the error. |
| E420 | No storage media is inserted. Press the RESET key to clear the error. Insert the storage media and then try again. |
| E421 | The program number is invalid or it has no corresponding data. Press the RESET key to clear the error. Check that data for this program number is present on the storage media. |
| E422 | Error occurred while reading from storage media. Check the data. Press the RESET key to clear the error. Check the data in the storage media. |
| E425 | Error occurred while writing to storage media. Check the storage media. It may be write-protected, or there is a possibility of a shortage of free space shortage in the storage media or a failure of the storage media. Press the RESET key to clear the error. Use the specified storage media. |
| E427 | The program containing the specified cycle program has been cleared. Press the RESET key to clear the error. Redo the cycle program. |
| E430 | Data cannot be backed up to the main P.C. board (flash memory). Turn off the power, and then turn it back on again. |
| E435 | The panel's internal memory cannot be accessed. Turn off the power, and then turn it back on again. |
| E440 | Data cannot be backed up to the main P.C. board (EEPROM). Turn off the power, and then turn it back on again. |
| E445 | The panel P.C. board (EEPROM) cannot be accessed. Turn off the power, and then turn it back on again. |
| E450 | Model selection cannot be read from the machine head memory. Turn off the power, and then check that connector P16 on the main P.C. board is properly connected. |
| E452 | Machine head memory is not connected. Turn off the power, and then check that connector P16 on the main P.C. board is properly connected. * If you press the RESET key to clear the error, you can restart the machine using the backup data in the machine head memory. |
| E453 | Problem with data in machine head memory. Turn off the power, and then turn it back on again. |
| E454 | Problem with data in machine head memory. Press the Reset key to clear the error and then the data will be recovered. |
| E471 | The program number is invalid or it has no corresponding data. Check that data for this program number is present in the internal memory. |
| E474 | Internal memory is full and copying is not possible. Press the RESET key to clear the error. Clear the sewing data. |

Data editing-related errors

| Code | Cause of error and remedy |
|------|--|
| E500 | The enlargement ratio setting caused the sewing data to extend outside the sewing area. Set the enlargement ratio again. Press the RESET key to clear the error. |
| E502 | The enlargement ratio caused the data pitch to exceed the maximum pitch of 20.0 mm. Press the RESET key to clear the error. Set the enlargement ratio again. |
| E510 | Error in sewing data. Press the RESET key to clear the error. If an error occurs while reading or revising the sewing data, revise the data. |

| Code | Cause of error and remedy |
|-------------|--|
| E511 | No end code has been input into pattern data. Press the RESET key to clear the error. |
| E512 | Number of stitches exceeds allowed maximum. Press the RESET key to clear the error. |
| E520 | Extended option output number already exists. Change the extended option output number. If not using the extended option output, initialize the data to clear the extended option output data. |
| E581 | Memory switch file cannot be read correctly. The model for the data which was read does not match the model being written to. Press the RESET key to clear the error. Read data for the same sewing machine model. |
| E582 | Memory switch versions do not match. Press the RESET key to clear the error. Read data for the same version. |
| E583 | User program versions do not match. Press the RESET key to clear the error. Read data for the same version. |

Device-related errors

| Code | Cause of error and remedy |
|-------------|--|
| E600 | Upper thread breakage occurred. Thread the upper thread. Re-sewing is then possible. Turn off the power, and then check that connectors P9 and P36 on the main P.C. board are properly connected. |
| E670 | Problem with the lower thread detector. Turn off the power, and then check the lower thread detector. |

P.C. board-related errors

| Code | Cause of error and remedy |
|-------------|--|
| E700 | Abnormal rise in power supply voltage. Turn off the power, and then check the input voltage. |
| E701 | Abnormal rise in upper shaft motor drive voltage. Turn off the power, and then check the voltage. |
| E702 | The motor P. C. board being used is not supported by this sewing machine. Ask the place of purchase for details. |
| E705 | Abnormal drop in power supply voltage. Turn off the power, and then check the input voltage. |
| E710 | Abnormal current detected in upper shaft motor. Turn off the power, and then check if there are any problems with the sewing machine. Turn off the power, and then check that connectors P11 and P1 on the motor P.C. board, connector P6 on the main P.C. board and the 4-pin connector of the upper shaft motor on the motor P.C. board are properly inserted. |
| E711 | Abnormal current detected in pulse motor. Turn off the power, and then check if there are any problems with the work clamp operation. |
| E730 | External error input (AIRSW) detected. Turn off the power, and then check the air pressure. |
| E740 | Control box cooling fan does not operate. Turn off the power, and then check if the cooling fan is blocked with scraps of thread. Check that connector P38 on the main P.C. board is properly connected. |
| E741 | X-feed motor cooling fan does not operate. Turn off the power, and then check if the cooling fan is blocked with scraps of thread. Check that connector P7 on the main P.C. board is properly connected. |
| E742 | Y-feed motor cooling fan does not operate. Turn off the power, and then check if the cooling fan is blocked with scraps of thread. Check that connector P7 on the main P.C. board is properly connected. |

8. LIST OF ERROR CODES

Version updating-related errors

| Code | Cause of error and remedy |
|---------------|--|
| E860 | No main control program is present. Update the main software. |
| E861 | The installed main software is not supported by the current panel software. Update the main software or the panel software. |
| E865 | No motor control program is present. Update the motor software. |
| E880 | Version update requests cannot be received. Turn off the power, and then turn it back on again. |
| E881 | Version updating did not complete normally. Turn off the power, and then repeat the version update procedure. |
| E883 | No control program is present in the storage media. Check that the control program has been saved into the correct folder. |
| E884 | There is a problem with the control program. Write the correct file into the storage media. |
| E887~ E890 | Version updating could not be carried out. Turn off the power, and then turn it back on again. |

Other errors

| Code | Cause of error and remedy |
|------|--|
| E920 | Failed to read bar code. Press the RESET key to clear the error. Read data for the same version. |
| E930 | Interface version of skipped stitch/thread breakage detection device is not supported. Please check the panel and the skipped stitch/thread breakage detection device software version. |
| E931 | No user software is installed in skipped stitch/thread breakage detection device. Please install user software. |
| E932 | Error is detected on the skipped stitch/thread breakage detection device. Please check the subcode and refer to the manual for details. |

If an error code that is not listed above appears or if carrying out the specified remedy does not solve the problem, contact the place of purchase.

9. TROUBLESHOOTING

- Please check the following points before calling for repairs or service.
- If the following remedies do not fix the problem, turn off the power and consult a qualified technician or the place of purchase.

CAUTION



Turn off the power switch and disconnect the power cord before carrying out these operations. The machine may operate if the foot switch is depressed by mistake, which could result in injury.

Items with a "*" in the "Reference" column should only be checked by a qualified technician.

| Problem | Cause | Remedy | Reference |
|--|--|---|-----------|
| Sewing machine does not start when the power is turned on and the foot switch is depressed. | Machine head switch does not work. | Check if the machine head switch cord is disconnected. | P. 12 |
| | | Adjust the position of the machine head switch. | P. 22 |
| | | If the machine head switch is malfunctioning, replace it with a new one. | |
| Work clamp does not work. | Air cock is closed. | Open the air cock. | P. 9 |
| | Air pressure is too weak. | Adjust the regulator so that the air pressure is about 0.5 MPa. | P. 51 |
| | Speed controller has been tightened too far. | Adjust the speed controller by loosening the Upper knob 5 turns and the Lower knob 8 turns from the fully-tightened position. | P. 52 |
| Thread wiper does not work. | Thread wiper setting is OFF. | Set the thread wiper setting to ON. | (*1) |
| Work clamp does not rise to the maximum height. | Work clamp lifter lever position is incorrect. | Adjust the position of the work clamp lifter lever. | P. 51 |
| Work clamp pressure is too weak. | Air pressure is too weak. | Adjust the regulator so that the air pressure is about 0.5 MPa. | P. 51 |
| Work clamp pressure is not uniform at front and back of work clamp. | Work clamp is tilted. | Adjust the tilt of the work clamp. | * |
| Thread wiper does not operate correctly. | The thread wiper is obstructing the needle. | Adjust the height of the thread wiper. | P. 50 |
| | | Adjust the operating stroke of the thread wiper. | P. 50 |
| | Thread wiper position is incorrect. | Adjust the operating stroke of the thread wiper. | P. 50 |

(Continued on next page)

(*1) Refer to the "LCD Panel" Instruction Manual.

9. TROUBLESHOOTING



| Problem | Cause | Remedy | Reference | |
|--|---|---|---|-------|
| Lower thread winds to one side. | Height of bobbin winder tension assembly is incorrect. | Adjust the height of the bobbin winder tension assembly. | P. 27 | |
| Lower thread winding amount is incorrect. | Bobbin presser position is incorrect. | Adjust the position of the bobbin presser. | P. 27 | |
| Thread unraveling at sewing start. | Needle is too thick. | Select a needle that is suitable for the sewing conditions. | P. 28 | |
| | Upper thread trailing length is too short. | When threading the thread through the needle, allow a distance of approximately 42 mm between the needle hole and the end of the thread. | P. 24 | |
| | | Adjust the sub-tension so that the upper thread trailing length after thread trimming is approximately 42 mm. | P. 29 | |
| | This is because the thread end can move freely at the sewing start. | Clamp the thread end at the sewing start with the intermittent presser foot motor. Ask the place of purchase for details on the setting method. | | |
| | | | | |
| Skipped stitches occur. | Rotary hook tip is missing. | Replace the part. | | |
| | Needle is too thin. | Select a needle that is suitable for the sewing conditions. | P. 28 | |
| | Needle is too thick. | | | |
| | Needle is bent. | Replace the needle. | P. 23 | |
| | Needle is not installed correctly. | Install the needle so that it faces correctly. | P. 23 | |
| | Needle and rotary hook tip are touching. | Adjust the driver needle guard. | P. 43 | |
| | Clearance between needle and rotary hook tip is too large. | Adjust the needle clearance. | P. 43 | |
| | Needle and rotary hook timing is incorrect. | Adjust the timing. | P. 42 | |
| | Material is flapping. | | Replace the needle hole plate with one with a smaller needle diameter. | |
| | | | Use a thinner feed plate. * Recommended thickness: 1.5 mm | |
| | | | Process the work clamp and the feed plate into shapes that can hold the material near the seam. | P. 53 |
| | | | Adjust the intermittent height of the intermittent presser foot. | (*1) |
| | | | | |
| Amount of lower thread being fed out from bobbin is too small. | Set the feeding amount to approximately 30 mm. | P. 27 | | |

(Continued on next page)

| Problem | Cause | Remedy | Reference |
|----------------------------------|---|---|----------------|
| Upper thread is breaking. | Thread is too thick for the needle. | Select a thread which is suitable for the needle. | P. 28 |
| | Needle is not installed correctly. | Install the needle so that it faces correctly. | P. 23 |
| | Thread is not threaded correctly. | Thread the thread correctly. | P. 24 |
| | Damage or burring in parts such as the rotary hook, needle hole plate, needle or thread path. | Repair the respective part by buffing it. Alternatively, replace the part. | |
| | Needle and rotary hook timing is incorrect. | Adjust the timing. | P. 42 |
| | Upper thread tension is too strong. | Reduce the upper thread tension. | P. 29 |
| | Thread take-up spring tension is too strong. | Reduce the tension of the thread take-up spring. | P. 41 |
| | Thread breaks due to heat. | Reduce the sewing speed. | (*1) |
| Lower thread is breaking. | Damage to the needle hole plate or bobbin case. | Repair the respective part by buffing it. Alternatively, replace the part. | |
| | Lower thread tension is too strong. | Reduce the lower thread tension. | P. 28 |
| Needle breaks. | Needle is bent. | Replace the needle. | P. 23 |
| | Needle is too thin. | Select a needle that is suitable for the sewing conditions. | P. 28 |
| | Needle and rotary hook tip are touching. | Adjust the driver needle guard. | P. 43 |
| | | Adjust the needle clearance. | P. 43 |
| | Needle and rotary hook timing is incorrect. | Adjust the timing. | P. 42 |
| Feed timing is too slow. | Advance the feed timing. | * | |
| Upper thread is not cut. | Movable knife is blunt. | Replace the movable knife with a new one. | P. 48 |
| | Fixed knife is blunt. | Sharpen the fixed knife or replace it with a new one. | P. 48 |
| | Movable knife is not picking up the upper thread. | Adjust the timing. | P. 42 |
| | | Adjust the standby position of the movable knife. | P. 45 P. 46 |
| | Movable knife is not picking up the needle thread because the last stitch is being skipped. | Refer to "Skipped stitches occur". | P. 63 |
| Lower thread is not cut. | Lower thread tension is too weak. | Increase the lower thread tension. | P. 28 |

(Continued on next page)

9. TROUBLESHOOTING

| Problem | Cause | Remedy | Reference |
|---|---|---|---------------------------------|
| Upper thread is not tight.  0573M | Needle is too thin. | Select a needle that is suitable for the sewing conditions. | P. 28 |
| | Hole diameter in needle hole plate is too small. | Replace the needle hole plate with one with a larger hole diameter. | |
| | Feed plate is too thin. | Use a thicker feed plate. *Recommended thickness: 1.5 mm | |
| | Hole diameter of intermittent presser foot is too small. | Replace the intermittent presser foot with one with a larger hole diameter. | |
| | Sliding parts of outer rotary hook and inner hook have little or no sewing machine oil. | Lubricate the felts for the sliding parts of the outer rotary hook and inner hook. | P. 21 |
| | Damage or burring in parts such as the rotary hook, needle hole plate, needle or thread path. | Repair the respective part by buffing it. Alternatively, replace the part. | |
| | Lower thread tension is too strong. | Reduce the lower thread tension. | P. 28 |
| | Upper thread tension is too weak. | Increase the upper thread tension. *Adjust the upper thread tension after adjusting the lower thread tension. | P. 29 |
| | Thread take-up spring tension is too weak. | Increase the tension of the thread take-up spring. | P. 41 |
| | Feed timing is too fast. | Retard the feed timing. | * |
| | Intermittent height of intermittent presser foot is too low. | Adjust the intermittent height of the intermittent presser foot. | (*1) |
| | Needle and rotary hook tip are touching. 0573M | | Adjust the driver needle guard. |
| | | Adjust the needle clearance. | P. 43 |
| Lower thread is not tight.  0574M | Lower thread tension is too weak. | Increase the lower thread tension. | P. 28 |
| | Upper thread tension is too strong. | Reduce the upper thread tension. *Adjust the upper thread tension after adjusting the lower thread tension. | P. 29 |
| Poor seam finish on underside of material at the sewing start. | Upper thread trailing length is too long. | Adjust the sub-tension so that the upper thread trailing length after thread trimming is approximately 42 mm. | P. 29 |
| Upper thread trailing length is irregular. | Movable knife is blunt. | Replace the movable knife with a new one. | P. 48 |
| | Fixed knife is blunt. | Sharpen the fixed knife or replace it with a new one. | P. 48 |
| | Sub-tension is too weak. | Adjust the sub-tension. | P. 29 |
| | Thread take-up spring tension is too weak. | Increase the tension of the thread take-up spring. | P. 41 |
| Pattern is distorted. | Work clamp and feed plate are too heavy. | If using a heavy work clamp and feed plate, change the operation settings to the settings for heavy-weight materials. Ask the place of purchase for details on the setting method. | * |
| | | | |
| | | | |
| Skipped stitch and thread breakage detector operates incorrectly | Thread has not been threaded along the correct route. | Thread the thread along the correct route. | P. 24 |

brother



INSTRUCTION MANUAL

* Please note that the contents of this manual may differ slightly from the actual product purchased as a result of product improvements.

BROTHER INDUSTRIES, LTD. <http://www.brother.com/>

1-5, Kitajizoyama, Noda-cho, Kariya 448-0803, Japan. Phone : 81-566-95-0088

© 2022 Brother Industries, Ltd. All Rights Reserved.

This is the original instructions.

BAS-341JX,BAS-342JX

I2091722D E

2022.09.D (1)