

brother

Internationale Industriemaschinen GmbH

Düsseldorfer Strasse 7-9

46446 Emmerich am Rhein, Germany

Tel.: +49 (0) 2822 609 0

E-mail: info@brother-ism.com

Web: industrialsewingmachine.global.brother

18 **Brother Automated Sewing BAS Bridge Type**

- 20 BAS-375H-05A
Bridge Type programmable electronic pattern sewer
with head lifting function
- 22 BAS-370H-05A
Bridge Type programmable electronic pattern sewer
with head lifting function
- BAS-365H-05A
Bridge Type programmable electronic pattern sewer
- BAS-360H-05A
Bridge Type programmable electronic pattern sewer

24 **Brother Automated Sewing BAS Standard**

- 26 BAS-311HX
Direct Drive programmable electronic pattern sewer with cylinder bed
- BAS-326H
Direct Drive programmable electronic pattern sewer with cylinder bed
- BAS-341H
Direct Drive programmable electronic pattern sewer with cylinder bed
- BAS-342HX
Direct Drive programmable electronic pattern sewer with cylinder bed
- 28 BAS-326H-484SF
Direct Drive programmable electronic pattern sewer with cylinder bed

30 **Brother Bonding**

- 32 BM-2000
Innovative seam construction "ISC" without sewing

34 **Bar-Tack Machines**

- 36 KE-430HS
Electronic direct drive lockstitch bar tacker
- 38 KE-430HX
Electronic direct drive lockstitch bar tacker
with digital tension and needle cooler

40 **Button Attaching Machines**

- 42 BE-438HS
Button Attaching Machine
- 44 BE-438HX
Button Attaching Machine
with digital tension

46 **Straight Buttonhole**

- 48 HE-800C
Straight button hole machine

50 **Eyelet Buttonhole**

- 52 RH-982A
Electronic eyelet buttonhole machine

54 **Unison Feed Series**

- 56 UF-8910
Single needle,direct drive, flat-bed, unison-feed machine with thread trimmer
- 58 UF-8920
Twin needle,direct drive, flat-bed, unison-feed machine with thread trimmer

60 **Single Needle**

- 62 **S-7780A**
Single Needle Direct Drive Lock Stitcher
with side cutter, electronic feeding system and thread trimmer
- 64 **S-7220D**
Single Needle Direct Drive Lock Stitcher
with needle feed and thread trimmer
- 66 **S-7300A**
Single Needle Direct Drive Lock Stitcher
with electronic feeding system and thread trimmer
- 68 **S-7250A**
Single Needle Direct Drive Lock Stitcher
with electronic feeding system and thread trimmer

70 **Twin Needle**

- 72 **T-8420C**
Twin Needle lock stitcher
- T-8450C**
Twin Needle lock stitcher with split needle bar
- T-8720C**
Twin Needle lock stitcher with large hook
- 74 **T-8421D**
Twin needle direct drive lock stitcher
- 76 **T-8422D**
Twin needle direct drive lock stitcher with thread trimmer
- T-8722D**
Twin needle direct drive lock stitcher with large hook and thread trimmer
- T-8452D**
Twin needle direct drive split needle bar lock stitcher with thread trimmer
- T-8752D**
Twin needle direct drive split needle bar lock stitcher with large hook
and thread trimmer

78 **ZigZag**

- 82 **Z-8550B**
Electronic direct drive zigzag lock stitch machine
- 84 **Z-8560B**
Electronic direct drive zigzag lock stitch machine with thread trimmer

84 **Feed off the arm**

- 86 **DA-927A**
Twin needle / Three needle feed off the arm double chain stitcher
- 88 **DA-928A**
Twin needle / Three needle feed off the arm double chain stitcher

About Brother

Since its inception in 1908, Brother has been at the forefront of product innovation, dedicated to delivering superior and innovative sewing technology to our customers.



About Brother

Brother is a Japanese company, whose profile comprises a diversity of electronic, industrial as well as domestic appliances, and is one of the world's leaders in the production of Industrial Sewing Machines and Printing. For the sale and promotion, Brother has subsidiaries all over the world. The industrial sewing machine tradition looks back upon 100 years' experience, and represents a considerable percentage of Brother's turnover. Brother headquarters for Industrial products like sewing machines and garment printer, in Europe, Africa and Middle East is located in Emmerich, Germany. Including our Branch office in Bologna (Italy) we are overall more than 70 employees, consisting of technicians, warehouse logistics staff, sales specialists, order processing specialists, marketing specialists and many more.

At the same time the Emmerich location is the Spare Parts Centre for all Europe and it stores more than 10.000 machine spare parts. Customer deliveries are processed daily under "Quick-Response-Philosophy". Everywhere we are present, be it in clothing, in the automotive industry with airbags and safety belts, in bags and suitcases, in safety protection and

environment, in the medicinal and biological areas and in the digital printing market. These are only a few areas, but it is important to stress our message "Brother at your side", which we practise every day, and our highest motto with this is customer satisfaction. The most important conditions next to our quality as a business partner, are the world-wide accepted Brother Quality products and the good service and local consultation structure.

As a reliable employer, the trading company also takes its social responsibility very serious. The slogan "At your side" documents the committed, responsible and cooperative attitude during all business decisions, also towards the environment.

At Brother in Emmerich as the whole Brother Group we feel that it is our duty to do whatever we can to protect and preserve our environment. For this reason we are ISO 14001 certified and make sure that our Brother products are compliant to RoHS "Restriction of the use of certain hazardous substances in electrical and electronic equipment". This means that Brother Products are in line with EU regulation

2002/95/EG. With all new developments of Brother Industrial machines we always aim to lower the energy consumption of our machines, but not losing the known Quality performance.

Brother Continues to Drive a New Era of Product Excellence and Industry Change

Since its inception in 1908, Brother has been at the forefront of product innovation, dedicated to delivering superior and innovative sewing technology to our customers. While these innovative changes have now become the industry standard, our never-ending spirit of challenge and innovation inherited from our ancestors have helped us surmount many challenges in the marketplace and continue striving for product excellence. It is with this spirit of pride and dedication that we introduce our new line of NEXIO industrial sewing machines.

This new brand name is derived from the words "Next" and "Society," combining our vision to drive a new era of industry change with continual dedication to innovative product development, as well as our continued company

commitment to forging strong customer relationships by being "At your side." his new brand name is derived from the words "Next" and "Society," combining our vision to drive a new era of industry change with continual dedication to innovative product development, as well as our continued company commitment to forging strong customer relationships by being "At your side."



Environment policy

Brother Internationale Industriemaschinen GmbH is a daughter company of Brother Industries Ltd., Nagoya/Japan and is responsible for the sales areas Europe, Africa and Middle East. As part of the global Brother Group, we have the obligation to realise the environment guidelines fixed by Japan for the total company business. According to the overall Brother Group philosophy, we will continue to develop and improve our environmental performance - in the interest and welfare of the general public. Environmental management is an essential part of our business decision making process and we strive to make continuous improvements to protect and preserve the environment. The environmental policy of our business is an equivalent and consistent component of the total business politics and strategy.

In order to further diminish our impact on the environment, Brother Internationale Industriemaschinen GmbH has adopted the company-wide Environmental Management system, which corresponds to the norms of ISO 14001. Within this framework we will continuously evaluate and improve our

environmental performance, and by applying Brother's own 5R concept we will promote the environment activities in our business as well as in cooperation with our trade partners. Brother Internationale Industriemaschinen GmbH does not manufacture products, but is more and more involved in product development and product specification. In this way we take influence, that the products as well as the packing materials are recyclable, and that these correspond to the respective environmental laws and standards. We continue to monitor the compliance of EU laws and guidelines.

In accordance with ISO 14001, we pay great attention to optimise the energy consumption by facilities and reduce environmentally hazardous waste and emissions to a minimum. In addition, the implementation of legal regulations in recycling (e.g. WEEE and RoHS) and the environmentally conscious actions of our employees are important to us. In future we will also integrate our suppliers into our activities and goals, and will more closely collaborate especially with forwarding companies. The objective is to regard the conservation of the environment as a joint concern and to reduce

our environmental influences wherever possible. We will regularly review our progress. We promise to expand our environmental activities effectively by integrating our personnel, external companies and customers - in the endeavour to persistently promote the environmental awareness. We will gladly familiarise our personnel, business partners and customers as well as any interested persons with our activities and strategies.

ISO14001

At Brother Emmerich, in order to minimise our impact on the environment, we have adopted the International Environmental Management System ISO 14001 standard. In March 2009, Brother Internationale Industriemaschinen successfully achieved full accreditation to this international standard. This was awarded following a detailed independent assessment by TÜV Süd Management Service GmbH, Munich, Germany, Cert. No. 12 104 35669 TMS. Fundamental to this standard is continual monitoring and measuring of our environmental performance so we can identify and implement improvements to protect and preserve the

environment. For this purpose in example we are reducing in house paper usage, energy consumption and the amount of Packaging Materials used. In return, we increase the amount for recycling and promote greater use of Duplex Printing. These are a small sample of the many areas of our activities which we empirically measure and report on a monthly basis to monitor our performance. At all times, Brother will operate within German and European Union environmental legislation and will continuously monitor such legislation as it progresses.

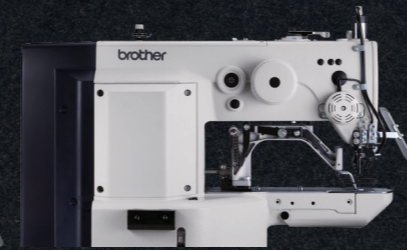
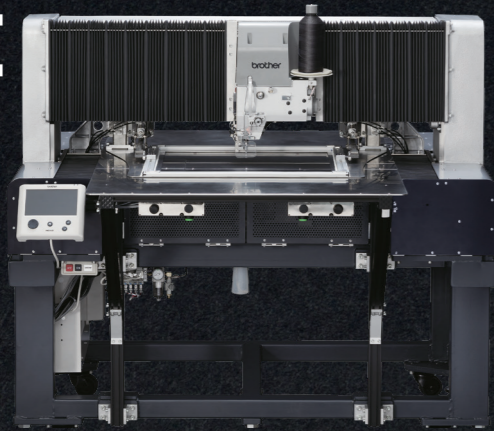

Brother Automated Sewing
BAS Bridge Type



- BAS-360H-05A
- BAS-365H-05A
- BAS-370H-05A
- BAS-375H-05A

Brother Automated Sewing
BAS Standard



- BAS-311HX
- BAS-326H
- BAS-326H-484SF
- BAS-341H
- BAS-342HX

Bar-Tack
Machines



- KE-430HS
- KE-430HX

Button Attaching
Machines



- BE-438HS
- BE-438HX

Unison Feed
Series



- UF-8910
- UF-8920

Brother
Bonding



- BM-2000



QR-Code leads to our website.

QR-Codes on the following pages lead to the official leaflets for each machine.

Pictogramm legend:

Apparel:

- Shirts
- Jeans
- Classical wear
- Workwear

Non-Apparel:

- Leather Goods
- Upholstery

Automotive:

- Interior/Car seats
- Airbag
- Seatbelt

Others:

- Others

Product range



Eyelet Buttonhole



RH-982A

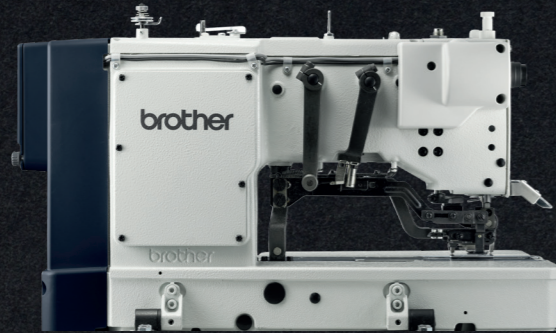

Straight Buttonhole



HE-800C



Single Needle

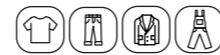

S-7780A
S-7220D
S-7300A
S-7250A



Twin Needle



T-8420C / T-8450C / T-8720C
T-8421D
T-8422D / T-8722D
T-8452D / T-8752D



ZigZag



Z-8550B
Z-8560B



Feed off the arm



DA-927A
DA-928A



QR-Code leads to our website.

QR-Codes on the following pages lead to the official leaflets for each machine.

Pictogramm legend:

Apparel:



Shirts



Jeans



Classical wear



Workwear

Non-Apparel:



Leather Goods



Upholstery

Automotive:



Interior/Car seats



Airbag



Seatbelt

Others:



Others

Brother Automated Sewing BAS Bridge Type

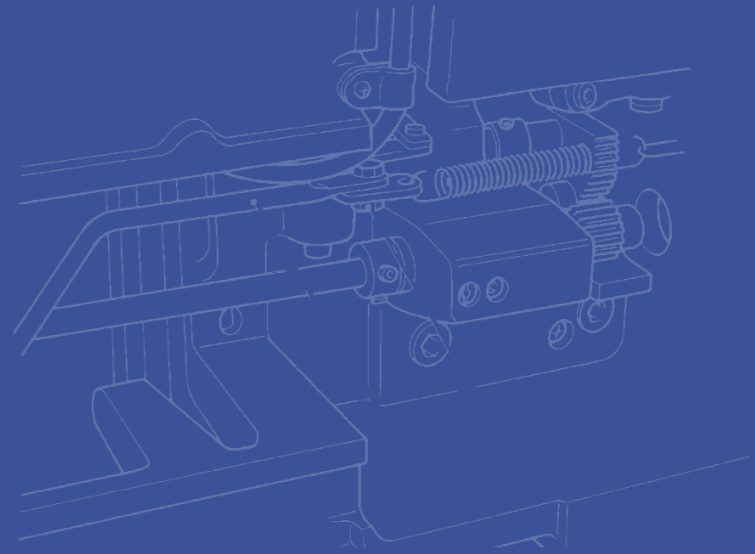
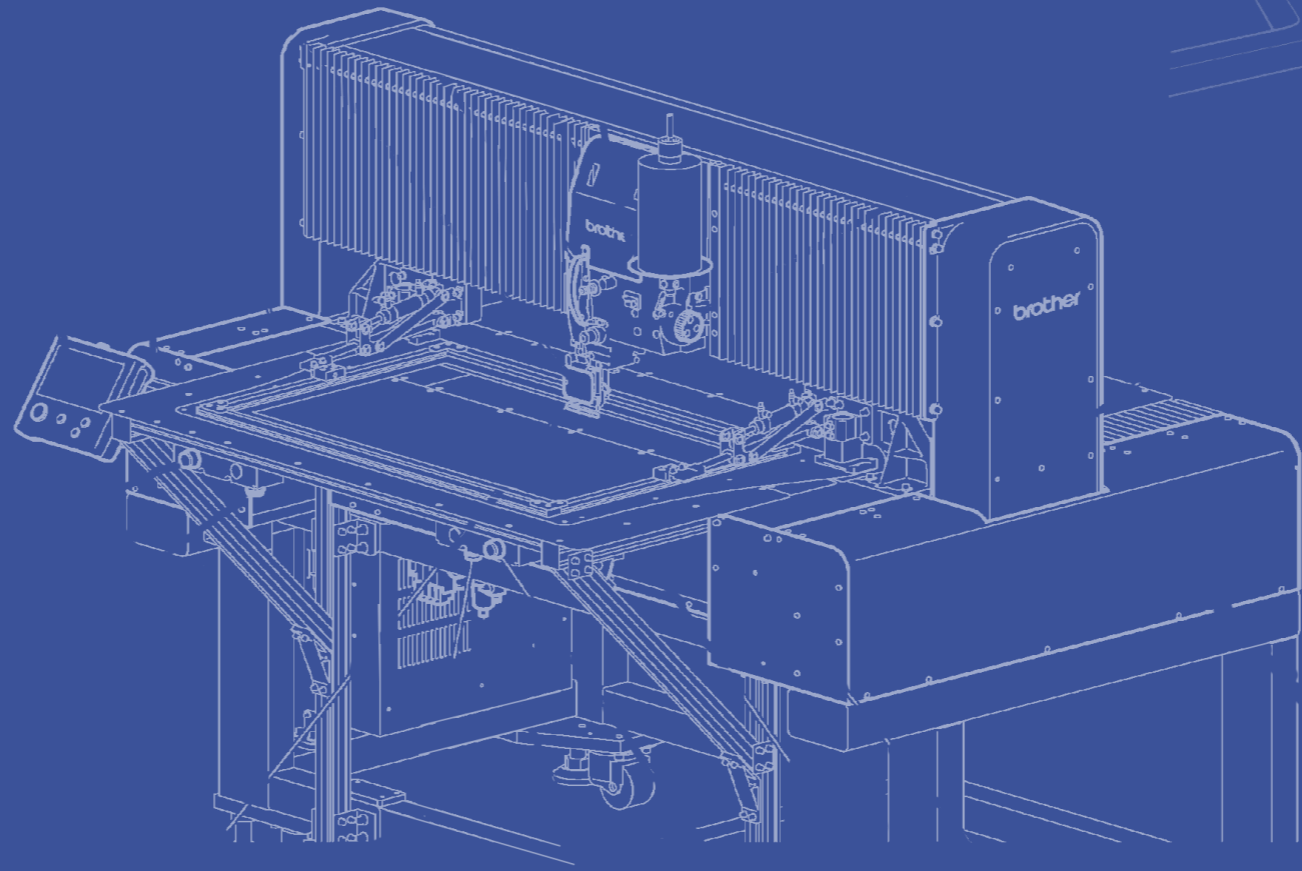
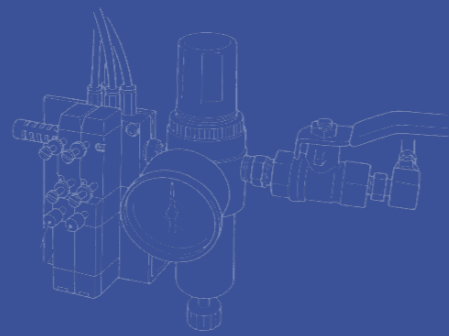

New Brother BAS series features a bridge type design that provides consistent sewing speeds and improved stitch quality on large area sewing applications.

BAS-360H BAS-365H

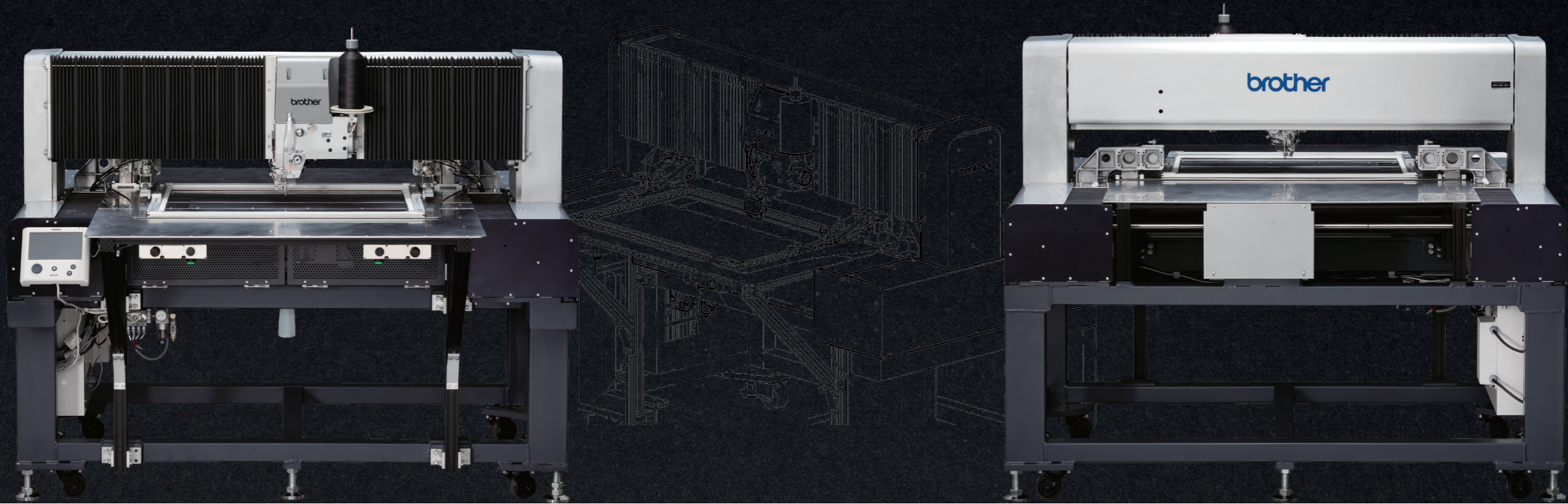

Bridge Type programmable electronic pattern sewer

New Brother BAS series features a bridge type design that provides consistent sewing speeds and improved stitch quality on large area sewing applications.

The large sewing area provides greater flexibility

The large sewing area allows to set multiple workpieces such as shoes or bags at the same time and to sew larger applications like automotive airbags. Bridge type mechanism has a feed mechanism of X and Y that drives independently so that it provides great sewing quality at higher sewing speeds. A needle cooler preventing thread breakage thus for greater sewing speeds.

Rotary Hook Spec

In addition to Shuttle Hook Spec, Rotary Hook Spec is also available. Rotary Hook Spec uses a "Rotary Hook" and "Rotary digital tension" to achieve more textured seams on leather products.

Specifications

Stitch form	Single needle lock stitch
Max. sewing speed	2,800 sti/min
Max number of stitches	20,000 stitches (per program)
Max number of programs	999
Work clamp lift amount	Pulse motor drive
2-step work clamp	Integrated-type work clamp
Height of stepping presser foot	25mm
Hook	Double-capacity shuttle hook <i>Double capacity rotary hook as option</i>
Thread wiper	Standard equipment
Thread trimmer	Standard equipment
Digital tension	Standard equipment
Thread breakage detector	Standard equipment
Data storage media	Internal flash memory (Data addition is available with external memory)

Model overview

	Feed	Sewing Area	Foot-print	Max. sewing speed	Stitch length	Air consumption	Digital tension	Needle cooler
BAS-360H	Intermittent (pulse motor)	500mm x 400mm	1489mm x 1296mm	2,700 sti/min	0.05mm-20.0mm	8l/min*	○	○
BAS-365H	Intermittent (pulse motor)	700mm x 400mm	1.699mm x 1.296mm	2,700 sti/min	0.05mm-20.0mm	8l/min*	○	○

*When needle cooler turns on



BAS-370H BAS-375H

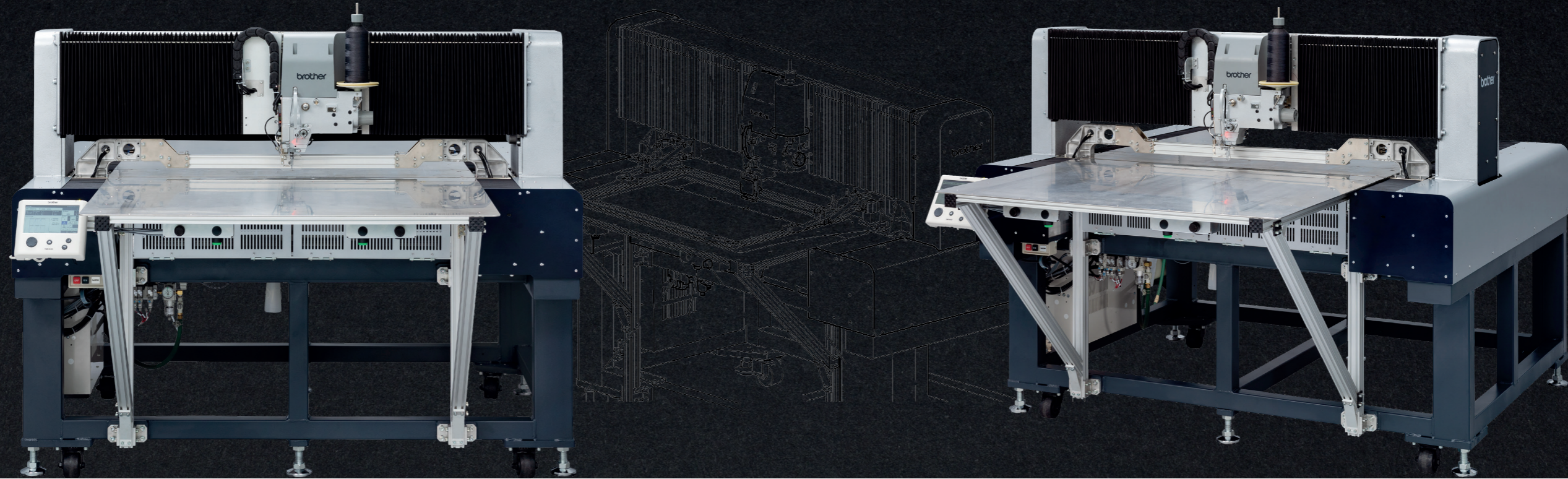

Bridge Type programmable electronic pattern sewer

New Brother BAS series features a bridge type design that provides consistent sewing speeds and improved stitch quality on large area sewing applications. Compared to the BAS-360H and BAS-365H, these two larger models are equipped with a head lifting function, which raises the head up to 95mm high. This enables an easy setting of the material into the clamp.

Ease of access to hook area is simplified

The auxiliary plate is fixed with a magnet which permits simple removal without using a tool. This ease of access allows for adjustment near the hook area to be accomplished easily. When adjusting the hook, the operator does not have to reach under the machine.

Effective utilization of factory floor space with compact footprint

The workspace footprint is extremely small for the larger sewing area provided when compared to conventional type BAS machines^{*1}, allows making additional space for another machine. Brother NEXIO series are IoT applicable models^{*2}. Connecting sewing machine to a network enables customers to analyze, manage processes, improve productivity, and monitor required maintenance.

^{*1} Programmable electronic sewing machine with sewing area larger than or equal to 200.00mm²
^{*2} It is applicable for Brother's IoT system.

Model overview

	Feed	Hook	Sewing Area	Footprint	Max. sewing speed	Max. stitch length	Air consumption	Digital tension	Needle cooler
BAS-370H	Intermittent (pulse motor)	Double capacity hook	700mm x 400mm	1.699mm x 2.076mm	2,500 sti/min	0.05mm-20.0mm	8l/min*	○	○
BAS-375H	Intermittent (pulse motor)	Double capacity hook	1200mm x 700mm	2.199mm x 2.076mm	2,500 sti/min	0.05mm-20.0mm	8l/min*	○	○

*When needle cooler turns on

Specifications

Stitch form	Single needle lock stitch
Max. sewing speed	2,500 sti/min
Feed mechanism	intermittent feed (pulse motor drive)
Stitch length	0.05-12.7mm (per 0.05mm)
Max number of stitches	20,000 stitches (per program)
Max number of programs	999
Work clamp lift amount	Pulse motor drive
2-step work clamp	Integrated-type work clamp
Height of stepping presser foot	25mm
Hook	Double-capacity shuttle hook <i>Double capacity rotary hook as option</i>
Thread wiper	Standard equipment
Thread trimmer	Standard equipment
Digital tension	Standard equipment (excluding the seat belt specification)
Thread breakage detector	Standard equipment
Data storage media	Internal flash memory (Data addition is available with external memory)



Brother Automated Sewing BAS Standard

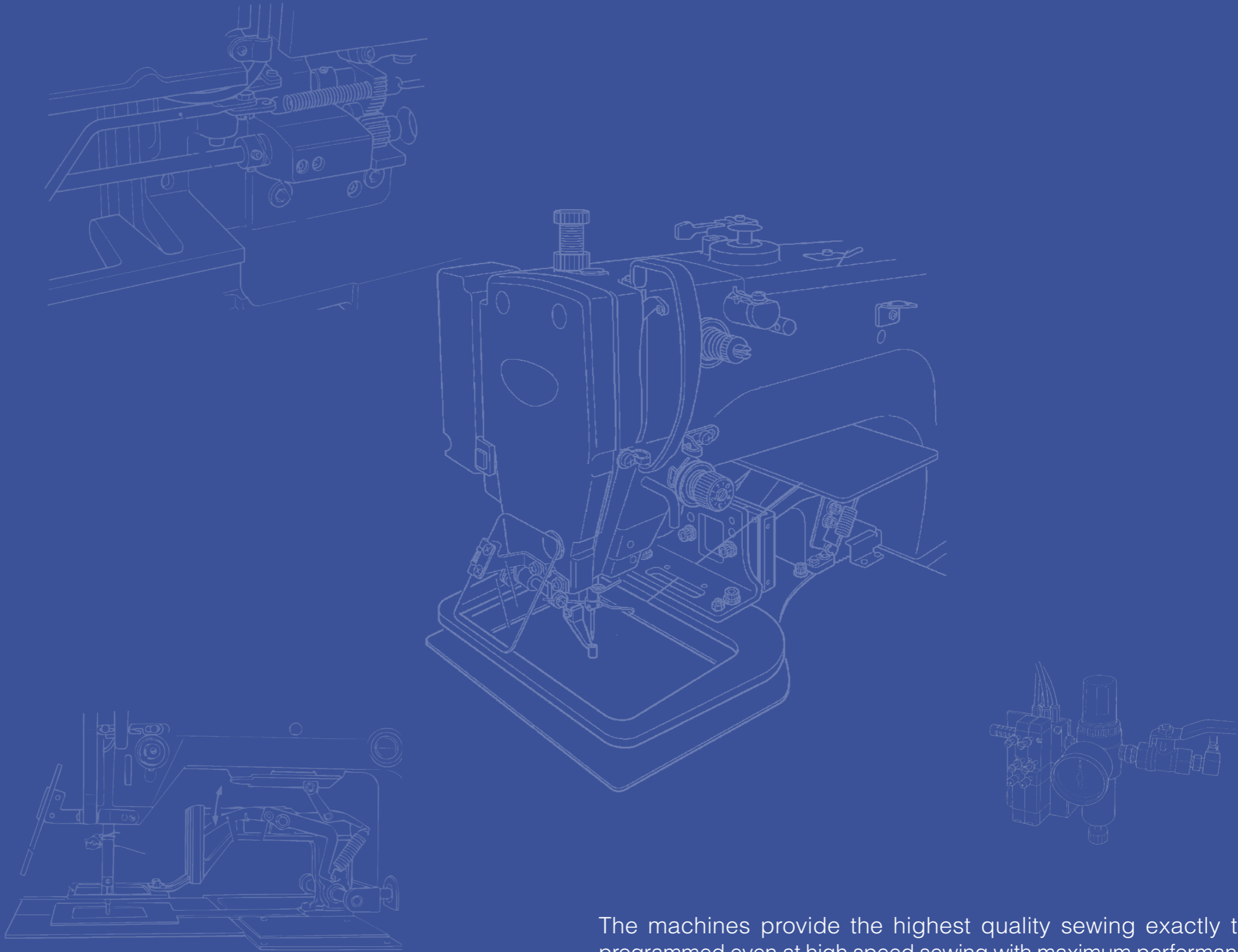

The machines provide the highest quality sewing exactly the way it is programmed even at high speed sewing with maximum performance according to each sewing area.

BAS-311HX BAS-326H
BAS-342HX BAS-341H

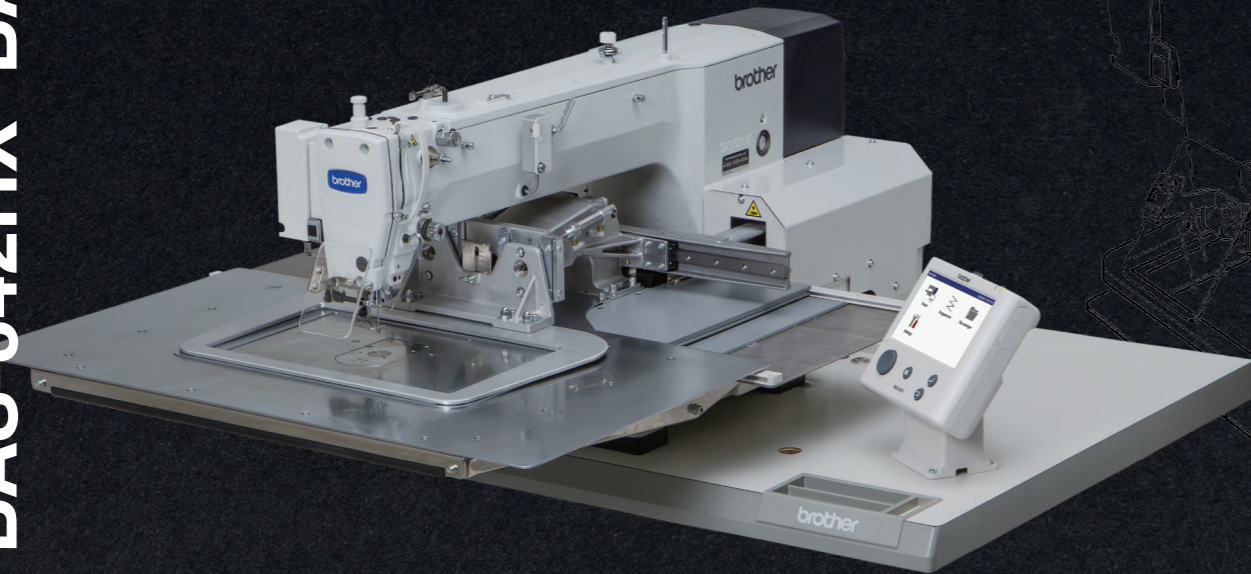

Direct Drive programmable electronic pattern sewer with cylinder bed

The machines provide the highest quality sewing exactly the way it is programmed even at high speed sewing with maximum performance according to each sewing area. With the high functional LCD touch panel that offers easy programming, the preparation time can be reduced.

Best user experience with LCD touch panel

With the high functional LCD touch panel that offers easy programming, the preparation time can be reduced. 7-inch large screen and easy programming functions via LCD touch panel enable an intuitive operation.

It can be understood very easy without the instruction manual or previous experience in fewer steps.

Model overview

	Feed	Hook	Sewing Area	2-step work clamp	Max. sewing speed	Max. stitch length	Air consumption
BAS-311HX	Intermittent (pulse motor)	Double capacity shuttle hook	150mm x 100mm	seperated work clamp	2,800 sti/min	0.05mm-12.7mm	1.8l/min
BAS-326H	Intermittent (pulse motor)	Double capacity shuttle hook	220mm x 100mm	seperated work clamp	2,800 sti/min	0.05mm-12.7mm	1.8l/min
BAS-341H	Intermittent (pulse motor)	Double capacity shuttle hook	250mm x 160mm	work clamp	2,800 sti/min	0.05mm-12.7mm	1.8l/min
BAS-342HX	Intermittent (pulse motor)	Double capacity shuttle hook	300mm x 200mm	work clamp	2,800 sti/min	0.05mm-12.7mm	1.8l/min

Specifications

Stitch form	Single needle look stitch
Max number of stitches	20,000 stitches (per program)
Max. number of programs	999
Work clamp lift amount	Max. 30mm
Height of stepping presser foot	22mm
Stepping presser foot stroke	2-4.5mm, 4.5mm-10mm or 0 (Default setting: 3mm)
Thread wiper	Standard equipment
Thread trimmer	Standard equipment
Digital tension	Standard equipment
Thread breakage detector	Standard equipment
Data storage media	Internal flash memory (Data addition is available with external memory)
Motor	AC servo motor 500W
Weight	Machine head: Approx. 88kg Control box: Approx. 9kg
Power	Single phase 100V/200V 3-phase 200V/220V/380V/400V
Air pressure / Consumption	0.5MPa 1.8 l/min
Work clamp lift amount	Max. 30mm



BAS-326H-484SF

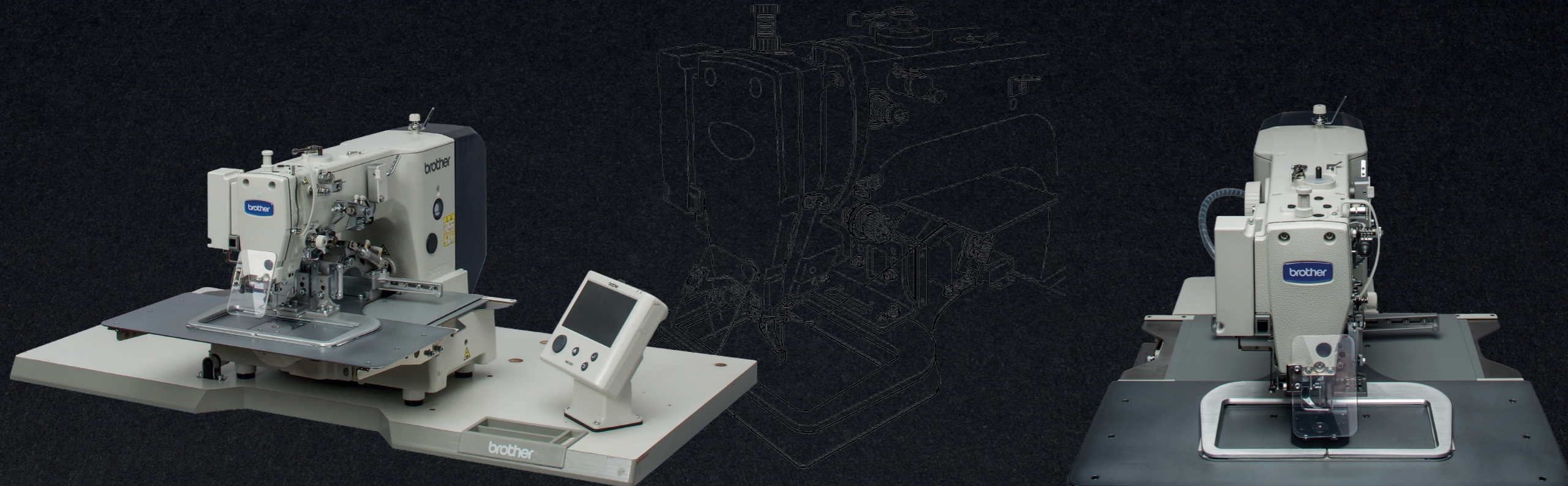

Direct Drive programmable electronic pattern sewer with cylinder bed and rotary hook

With the enlarged sewing area, the machine brings accurate and strong sewing for heavy and extra-heavy materials. The high functional LCD touch panel that offers easy programming, helps to reduce the preparation time.

Accurate and strong sewing even for extra-heavy materials

The use of the advanced controlled, heavy duty feed mechanism provides excellent, superb stitch quality and tight stitching even for extra-heavy sewing applications. Also, the upper thread feeding device which supplies the necessary length of upper thread at the start of sewing, preventing the thread from pulling out regardless of the material feeding amount.

Accurate thread wiper and thread cutting by pneumatic cylinders

The thread wiper and thread cutting mechanism are driven by pneumatic cylinders. The upper thread can be wiped accurately even under conditions where the thread is difficult to pull out of the material. The strong air pressure allows extra thick threads to be cut accurately and consistently.

Specifications

Stitch form	Single needle lock stitch
Max number of stitches	20,000 stitches (per program)
No. of sewing data items that can be stored	999 (internal memory, SD card, USM memory)
Work clamp height	Max. 27.5mm
Presser foot lift amount	19.5mm
Wiper device	Standard equipment
Thread wiper	Standard equipment
Thread take-up lever	Standard equipment
Thread breakage detector	Standard equipment
Cycle programs	30
Motor	AC servo motor, 550W
Weight	Machine head approx.88kg, LCD panel approx. 0.8kg, Control box 9kg (differs depending on destination)
Power	Single-phase 110V / 220V / 230V, 3-phase 220V / 380V / 400V (For single-phase 100V and 3-phase 380V / 400V, the trans box is required)
Air pressure	0.5MPa

Model overview

	Feed	Hook	Sewing Area	2-step work clamp	Max. sewing speed	Max. stitch length	Air consumption
BAS-236H-484SF	Intermittent (pulse motor)	Rotary treble hook	220mm x 100mm	seperated work clamp	2,200 sti/min	0.05mm-12.7mm	1.8l/min



Bonding

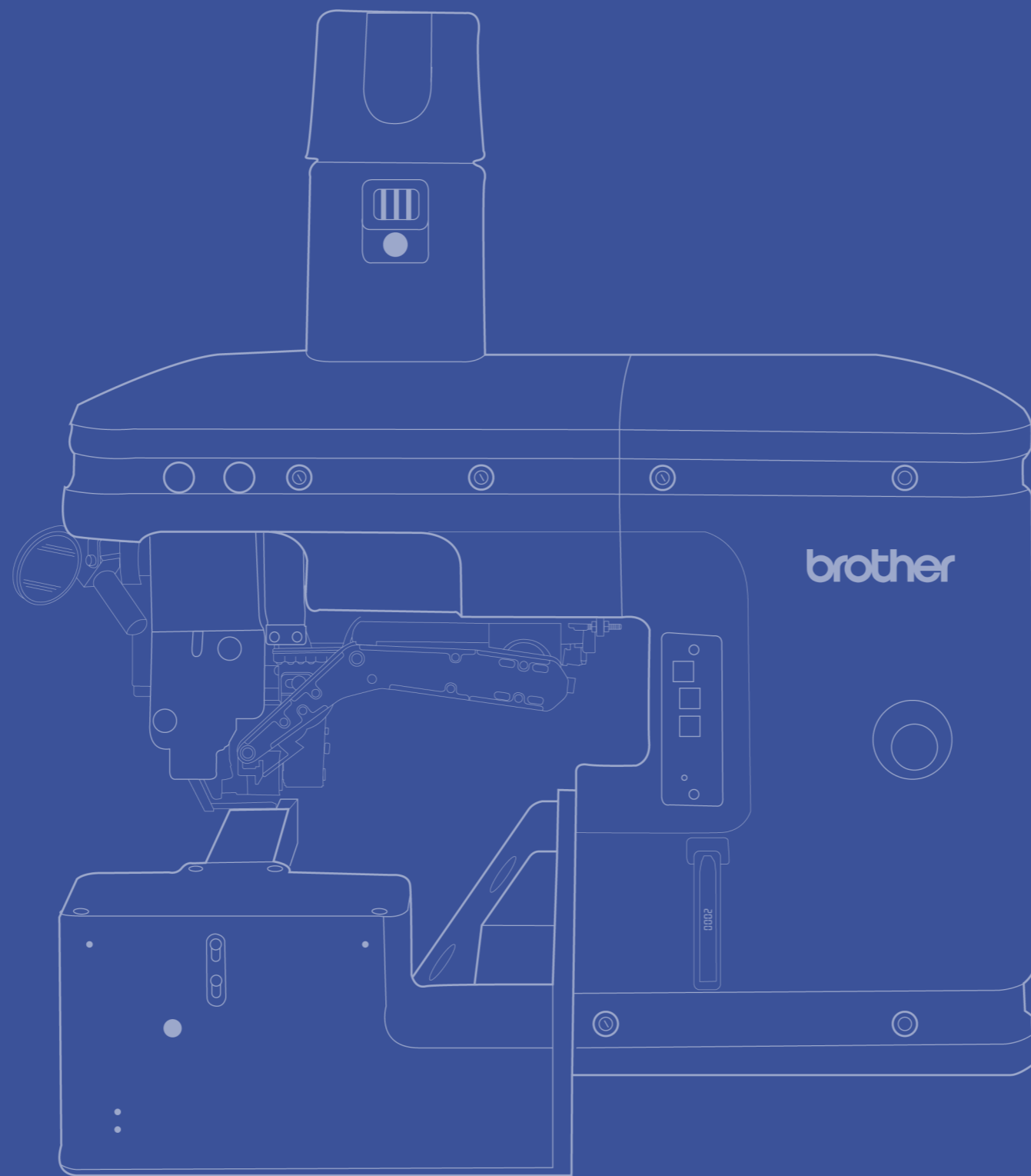

Various designs can be created with Brother "ISC" technology - The applying of adhesive and the bonding of the cloth are performed at the same time. This contributes to the creation of new designs not limited by the press mold.

BM-2000

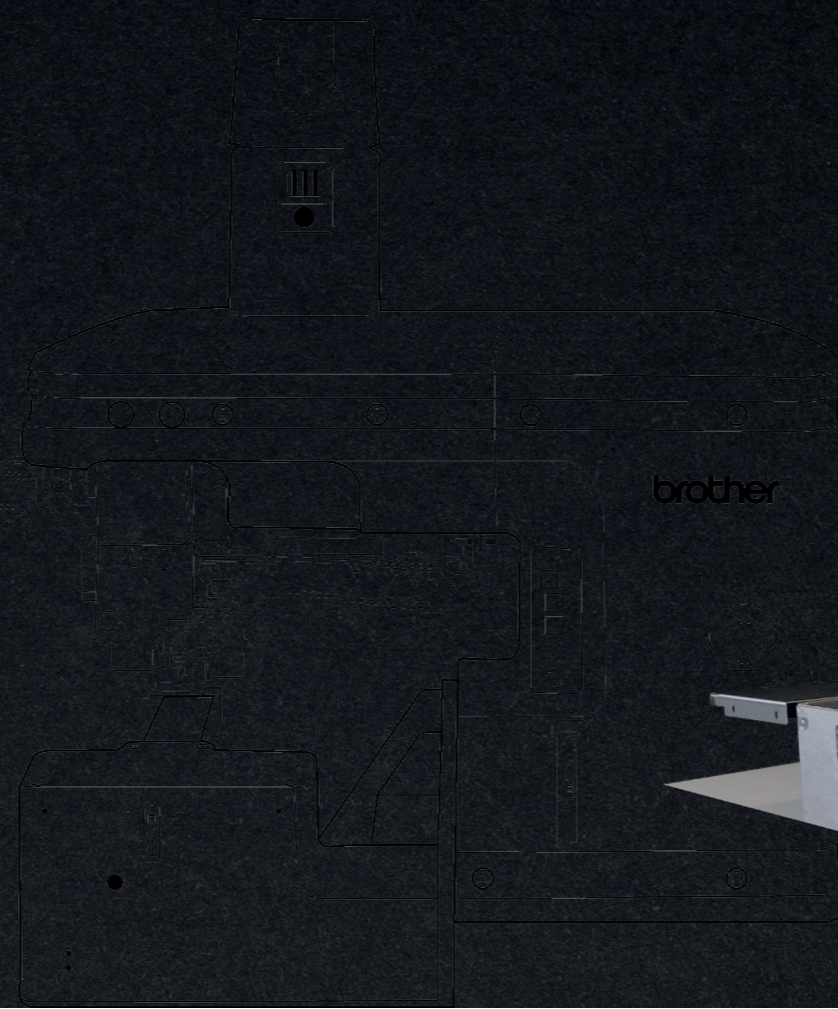

Innovative seam construction without sewing

Various designs can be created with Brother “ISC” technology - The applying of adhesive and the bonding of the cloth are performed at the same time. This contributes to the creation of new designs not limited by the press mold.

This technology can also process tubular seams. The slender cylinder design of the BM-2000 bonding machine increases the possibilities of use such as long sleeves for ladies' garments.*¹

Anyone can more easily and beautifully create seams without sewing. The smooth curve design can be created beautifully without exposing the adhesive at the cloth edge by controlling fabric edge positioning with sensor technology. Greater fabric choices are now possible, since the temperature of the adhesive is only 120 degrees low, you can select the fabric without concern for damage due to heat and shine. This provides a wider range of fabrics possible for your designs.

*¹ Machine cylinder circumference 160mm

Creating stress-free comfort garments with a high fit feeling is achieved by using the BM-2000 and an in-house developed adhesive. Peel strength is 1.5 times higher than conventional tape type, and 1.5% improvement in elongation recovery rate.

Specifications

Machine construction	Feed off the arm, easy convertible to flatbed
Bonding process	Overlapping
Machine heating up time	15 minutes
Feed speed	0,5 - 5,0 meter/min
Glue thickness	50 - 200 micrometer
Nozzle bonding widths	8 mm standard; 4, 6 and 10 mm as option
Length that can be adhered with one cartridge	150 - 620 meters* ¹
Material transport	Upper and lower puller
Material guiding	Upper and lower edge sensors
Nozzle clearance	0,1 - 2,5 mm
Min. tubular length	160 mm
Number of program	30
Number of steps per program	8

*¹ depends on feed speed, glue thickness and nozzle bonding width



Bar-Tack Machines

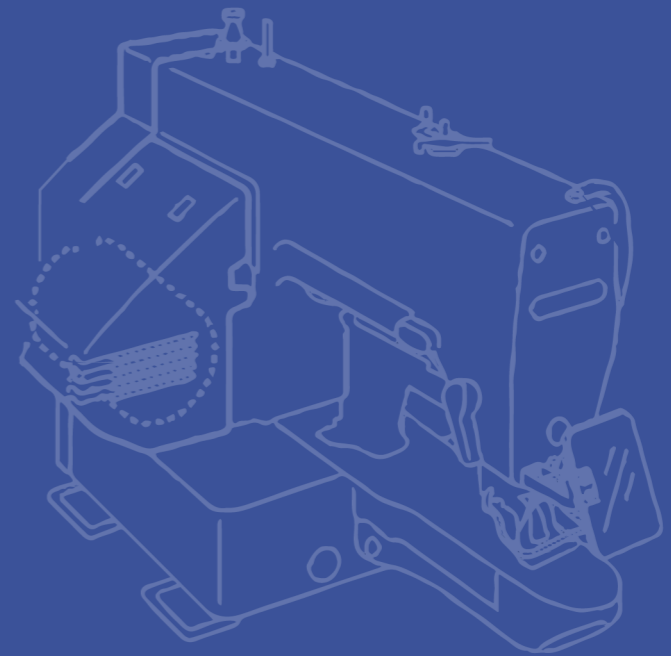
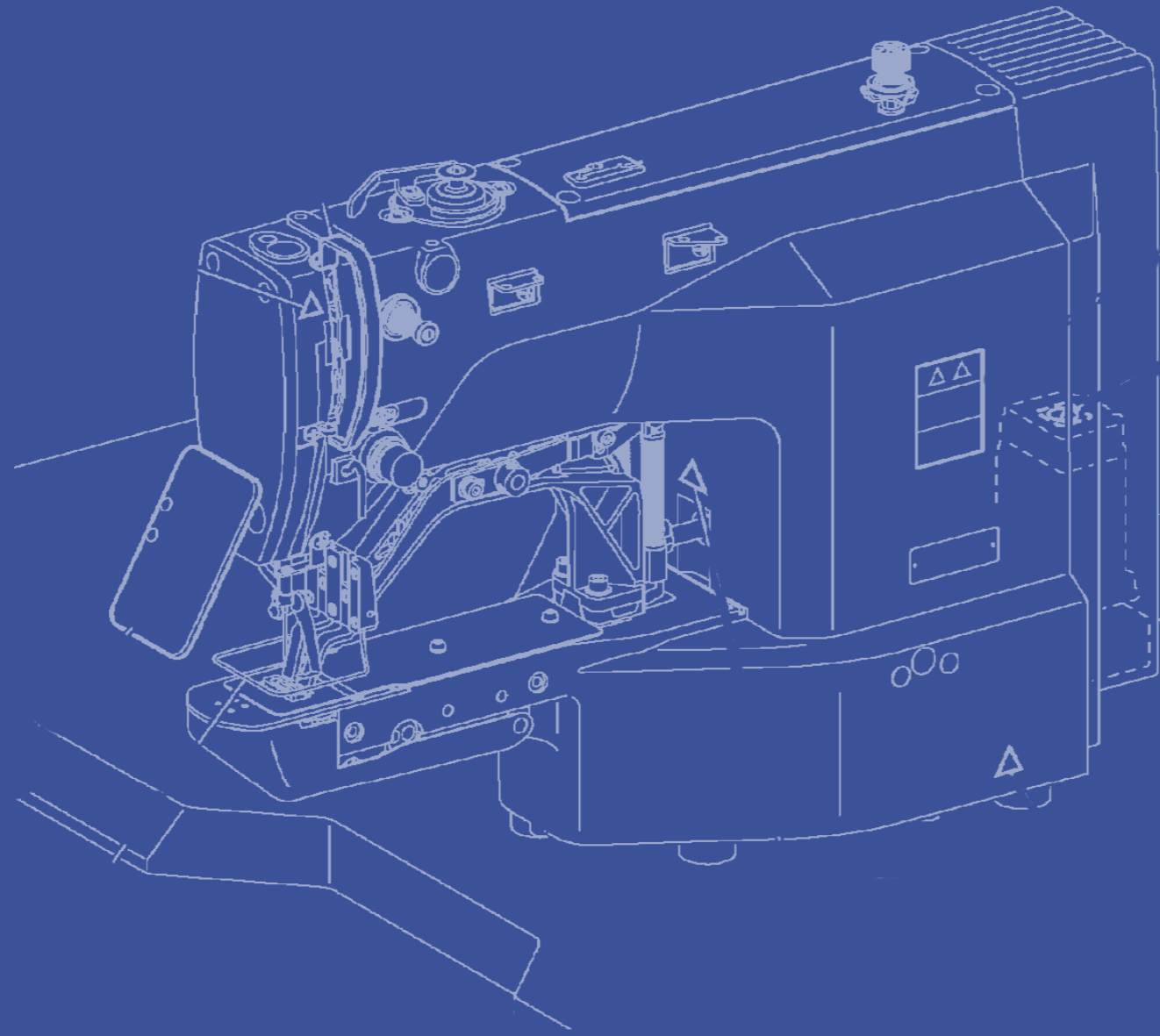

With the world's top-class sewing speed and prevention of thread breakage, the machine has increased productivity. It also has superior sewing quality, usability, and reduces maintenance cost.

KE-430 HS

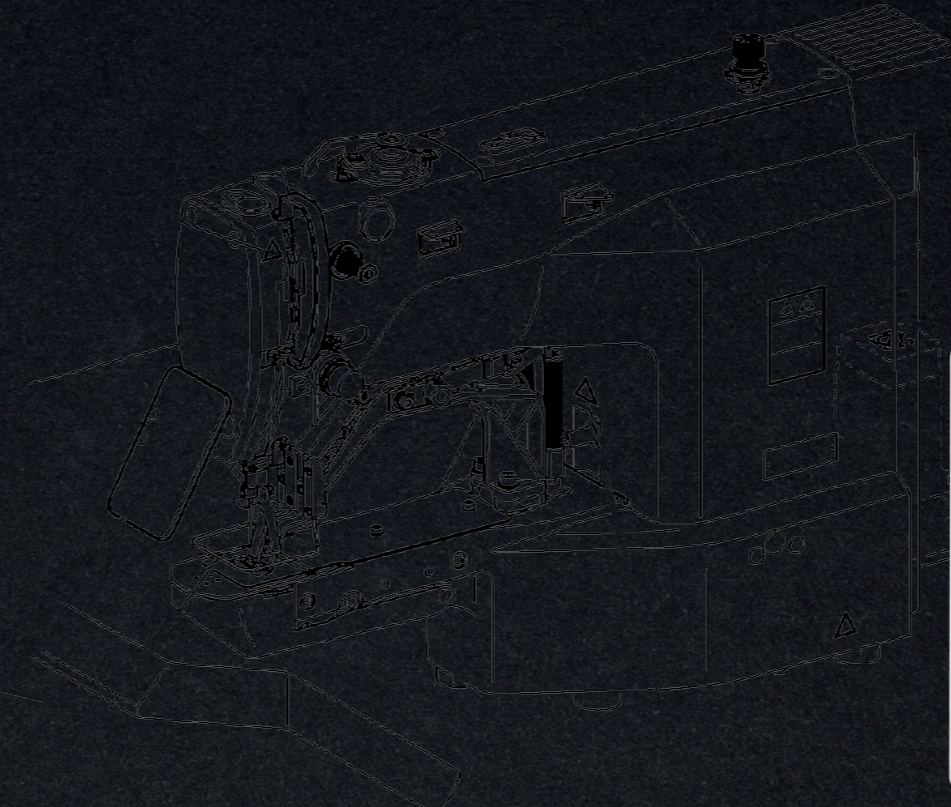

Electronic Direct Drive Lockstitch Bar Tacker

With the world's top-class sewing speed and prevention of thread breakage the machines have increased productivity. It also has superior sewing quality, usability, and reduces maintenance cost. Productivity improvement by world's fastest sewing speed and IoT, beautiful and highly-reproducible sewing quality, superior usability as everyone can use easily and reliably.

Productivity Improvement

Our NEXIO series are capable to be connected to our IoT system, which enables the customer to analyze, manage and process the production flow. New technologies, paired with mechanical optimization like our step motor driven short thread cutting system which works quiet and reliable, are making our KE/BE series to a state-of-the-art solution.

Color LCD touch panel

The touch panel offers a user-friendly interface, which makes it easy to set the sewing patterns, create cycle programs, adjust the sewing speed, or storing the upper thread tension in the user programs (HX-series only).

Model overview

	Application	Tension	Lubrication	Max. sewing speed
KE-430 HS-03	medium materials	Standard tension	minimum lubrication	3,300 sti/min
KE-430 HS-05	heavy materials	Standard tension	minimum lubrication	3,300 sti/min

Specifications

Sewing area	Standard 40 x 30mm (optional 50 x 40mm)
Stitch length	0.05 ~ 12.7mm
Needle cooler	Not available
Feed mechanism	Intermittent feed mechanism (pulse-motor driven)
Max. No. of stitches	5,000 stitches/pattern
Work clamp lifter	Pulse motor drive system
Work clamp height	Max. 17mm
Hook	Shuttle hook (double capacity shuttle hook optional)
Digital tension	Not available
Thread wiper	Standard equipment
Thread trimmer	Standard equipment
Thread nipper	optional
Data storage method	Internal flash memory (Data addition is available with external memory)
No. of cycle programs	30 cycle (50 programs for each cycle)
No. of stored data	89 sewing patterns are set already (Up to 500 patterns can be added. Total number of stitches of stored data which can be added is within 500,000)
Motor	AC servo motor 550W (Direct Drive)
Weight	Machine head: Approx. 58kg, Operation panel: Approx. 0.5kg, Control box: Approx. 7kg
Power supply	Single-phase 100V/220V, 3-phase 220V/380V/400V 400VA (For single-phase 100V and 3-phase 380V/400V, the trans box is required.)



KE-430 HX

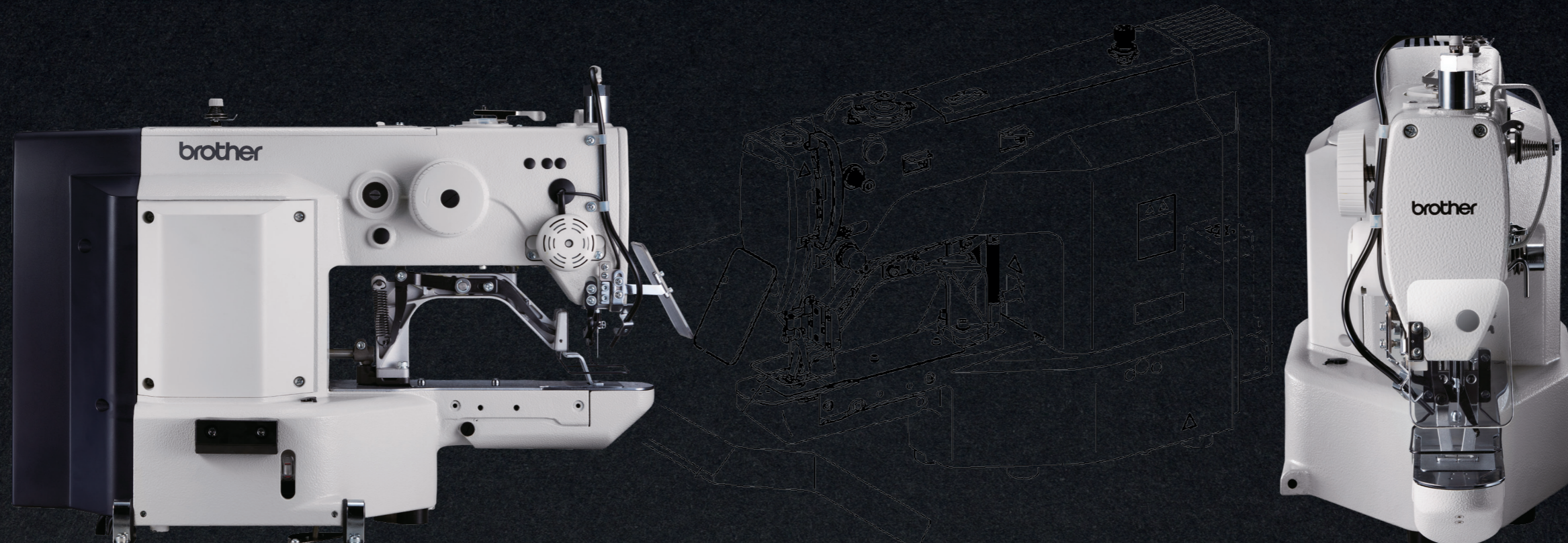

Electronic direct drive lockstitch bar tacker

With the world's top-class sewing speed and prevention of thread breakage with a needle cooler, the machine has increased productivity. It also has superior sewing quality, usability, and reduces maintenance cost. Productivity improvement by world's fastest sewing speed and IoT, beautiful and highly-reproducible sewing quality, superior usability as everyone can use easily and reliably.

Productivity Improvement

Our NEXIO series are capable to be connected to our IoT system, which enables the customer to analyze, manage and process the production flow. New technologies, paired with mechanical optimization like our step motor driven short thread cutting system which works quiet and reliable, are making our KE/BE series to a state-of-the-art solution.

Needle cooler

The HX-versions of our bar-tack machines, are equipped with a needle cooling system, to prevent thread breakages and increase the actual sewing speed by 10% compared to our previous F-series.

Model overview

	Application	Tension	Lubrication	Max. sewing speed
KE-430 HX-01	light materials	Digital tension	semi-dry	3,300 sti/min
KE-430 HX-03	medium materials	Digital tension	semi-dry	3,300 sti/min
KE-430 HX-05	heavy materials	Digital tension	semi-dry	3,300 sti/min
KE-430 HX-OK	knitted materials	Digital tension	semi-dry	3,300 sti/min

Specifications

Sewing area	Standard 40 x 30mm (optional 50 x 40mm)
Stitch length	0.05 ~ 12.7mm
Needle cooler	Standard
Feed mechanism	Intermittent feed mechanism (pulse-motor driven)
Max. No. of stitches	5,000 stitches/pattern
Work clamp lifter	Pulse motor drive system
Work clamp height	Max. 17mm
Hook	Shuttle hook (double capacity shuttle hook optional)
Digital tension	Standard equipment
Thread wiper	Standard equipment
Thread trimmer	Standard equipment
Thread nipper	-01,-03,-0K:Standard equipment -05:Option
Data storage method	Internal flash memory (Data addition is available with external memory)
No. of cycle programs	30 cycle (50 programs for each cycle)
No. of stored data	89 sewing patterns are set already (Up to 500 patterns can be added. Total number of stitches of stored data which can be added is within 500,000)
Motor	AC servo motor 550W (Direct Drive)
Weight	Machine head: Approx. 58kg, Operation panel: Approx. 0.5kg, Control box: Approx. 7kg
Power supply	Single-phase 100V/220V, 3-phase 220V/380V/400V 400VA (For single-phase 100V and 3-phase 380V/400V, the trans box is required.)



Button attaching machines

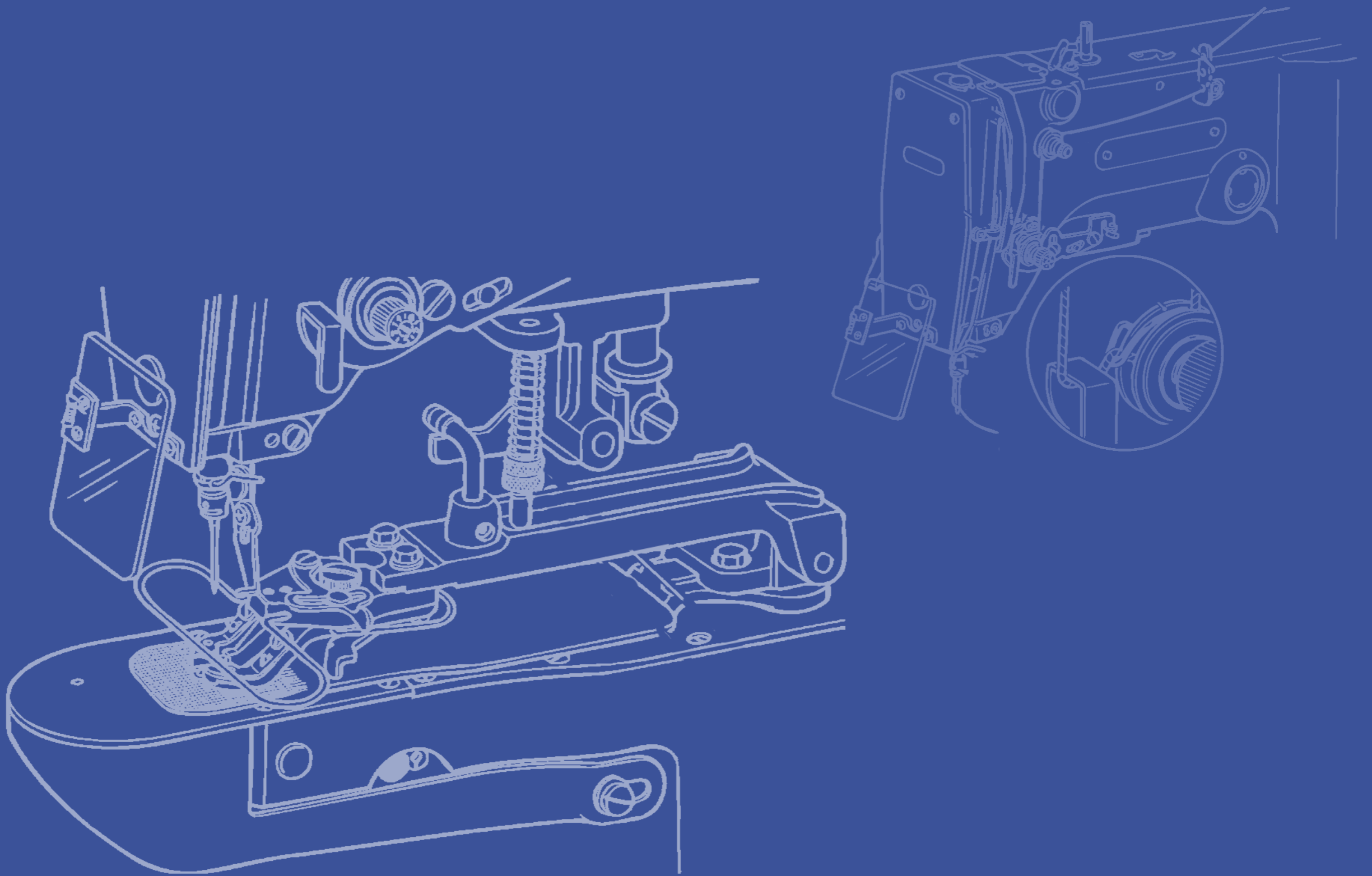

Our renewed button clamp enables to set a button more smoothly.

BE-438HS

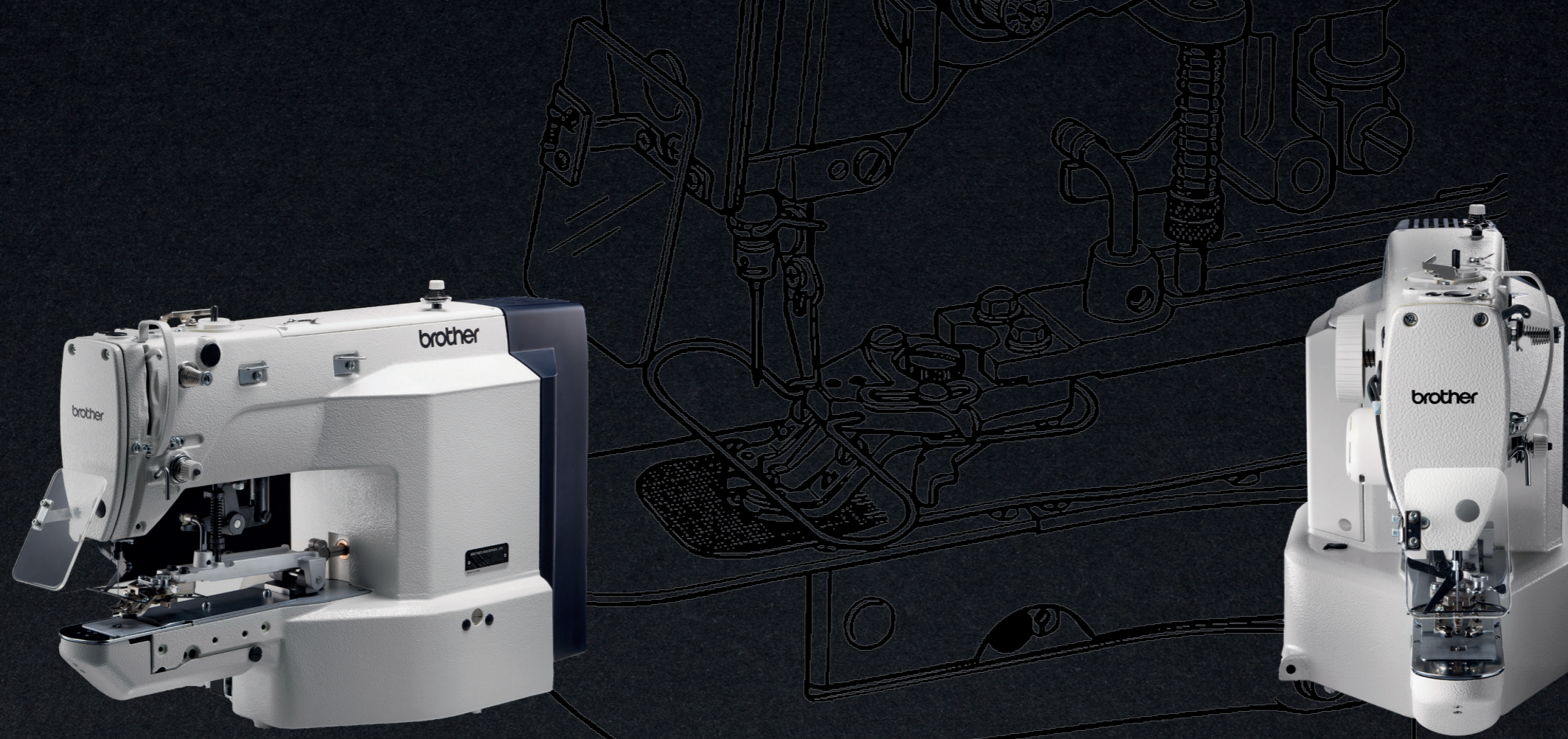

Set button smoothly

Our renewed button clamp enables to set a button more smoothly.

Productivity improvement

Our NEXIO series are capable to be connected to our IoT system, which enables the customer to analyze, manage and process the production flow. New technologies, paired with mechanical optimization like our step motor driven short thread cutting system which works quiet and reliable, are making our KE/BE series to a state-of-the-art solution.

Color LCD touch panel

The touch panel offers a user-friendly interface, which makes it easy to set the sewing patterns, create cycle programs, adjust the sewing speed, or storing the upper thread tension in the user programs (HX-series only).

Model overview

	Application	Tension	Lubrication	Max. sewing speed
BE-438 HS	button attaching	Standard tension	minimum lubrication	2,800 sti/min

Specifications

Sewing area	Max. 6.4 x 6.4mm
Dimensions of buttons that can be sewn	Outer diameter of buttons 8 - 30mm*1
Stitch length	0.05 ~ 6.4mm
Needle cooler	Not available
Feed mechanism	Intermittent feed mechanism (pulse-motor driven)
Max. No. of stitches	5,000 stitches/pattern
Work clamp lifter	Pulse motor drive system
Button clamp height	Max. 13mm
Hook	Shuttle hook
Thread trimmer	Standard equipment
Thread wiper	Standard equipment
Thread nipper	Option
Data storage method	Internal flash memory (Data addition is available with external memory)
No. of cycle programs	30 cycle (50 programs for each cycle)
No. of stored data	64 sewing pattern are set already (Up to 500 patterns can be added. Total number of stitches of stored data which can be added is within 500,000.)
Motor	AC servo motor 550W (Direct Drive)
Weight	Machine head: Approx. 58kg, Operation panel: Approx. 0.5kg, Control box: Approx. 7kg
Power supply	Single-phase 100V/220V, 3-phase 220V/380V/400V 400VA (For single-phase 100V and 3-phase 380V/400V, the trans box is required.)

*1 Use the optional button clamp (SA9303201) for diameters of 2mm or greater



BE-438HX



Set button smoothly

Our renewed button clamp enables to set a button more smoothly.

Thread tension can be set as numerical value by digital tension

You can adjust the tension appropriately for the material being sewn without relying on individual feel. It provides higher production management and sewing reproducibility.

Productivity improvement

Our NEXIO series are capable to be connected to our IoT system, which enables the customer to analyze, manage and process the production flow. New technologies, paired with mechanical optimization like our step motor driven short thread cutting system which works quiet and reliable, are making our KE/BE series to a state-of-the-art solution.

Model overview

	Application	Tension	Lubrication	Max. sewing speed
BE-438 HX	button attaching	Digital tension	semi-dry	2,800 sti/min

Specifications

Sewing area	Max. 6.4 x 6.4mm
Dimensions of buttons that can be sewn	Outer diameter of buttons 8 - 30mm*1
Stitch length	0.05~6.4mm
Needle cooler	Standard
Feed mechanism	Intermittent feed mechanism (pulse-motor driven)
Max. No. of stitches	5,000 stitches/pattern
Work clamp lifter	Pulse motor drive system
Button clamp height	Max. 13mm
Hook	Shuttle hook
Thread trimmer	Standard equipment
Thread wiper	Standard equipment
Thread nipper	Option
Data storage method	Internal flash memory (Data addition is available with external memory)
No. of cycle programs	30 cycle (50 programs for each cycle)
No. of stored data	64 sewing pattern are set already (Up to 500 patterns can be added. Total number of stitches of stored data which can be added is within 500,000.)
Motor	AC servo motor 550W (Direct Drive)
Weight	Machine head: Approx. 58kg, Operation panel: Approx. 0.5kg, Control box: Approx. 7kg
Power supply	Single-phase 100V/220V, 3-phase 220V/380V/400V 400VA (For single-phase 100V and 3-phase 380V/400V, the trans box is required.)

*1 Use the optional button clamp (SA9303201) for diameters of 2mm or grater



Straight Buttonhole

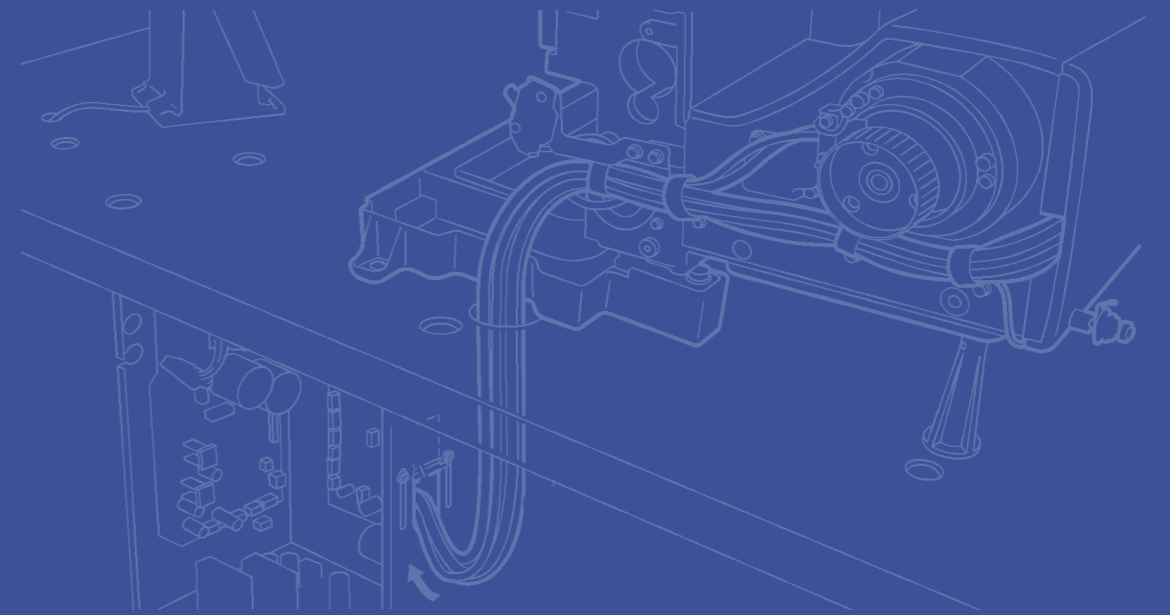
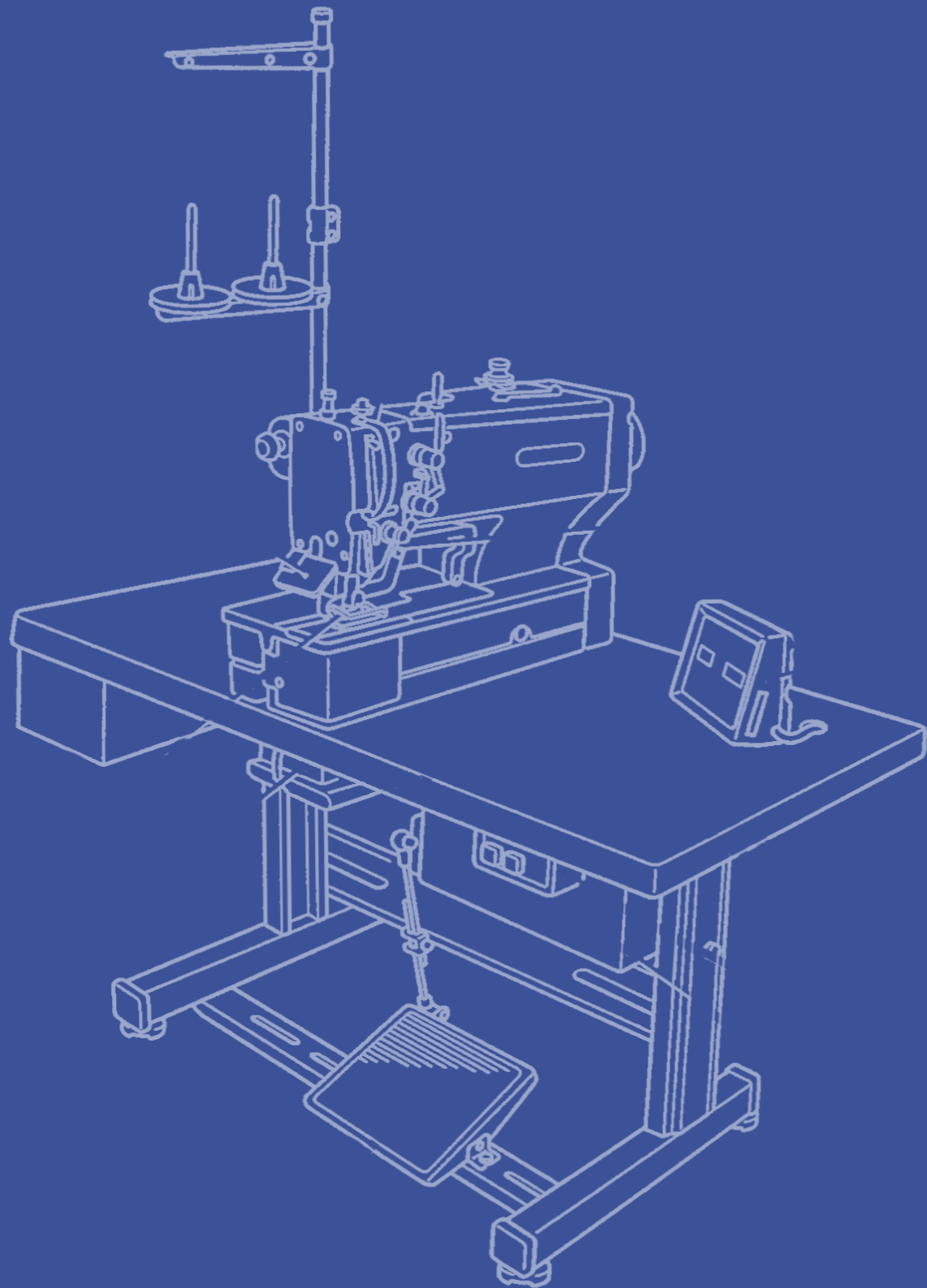

High quality sewing due to modified parts and program. High productivity due to double cutting function. Reduction of disposition of thread ends. Productivity improvement by IoT.

HE-800C

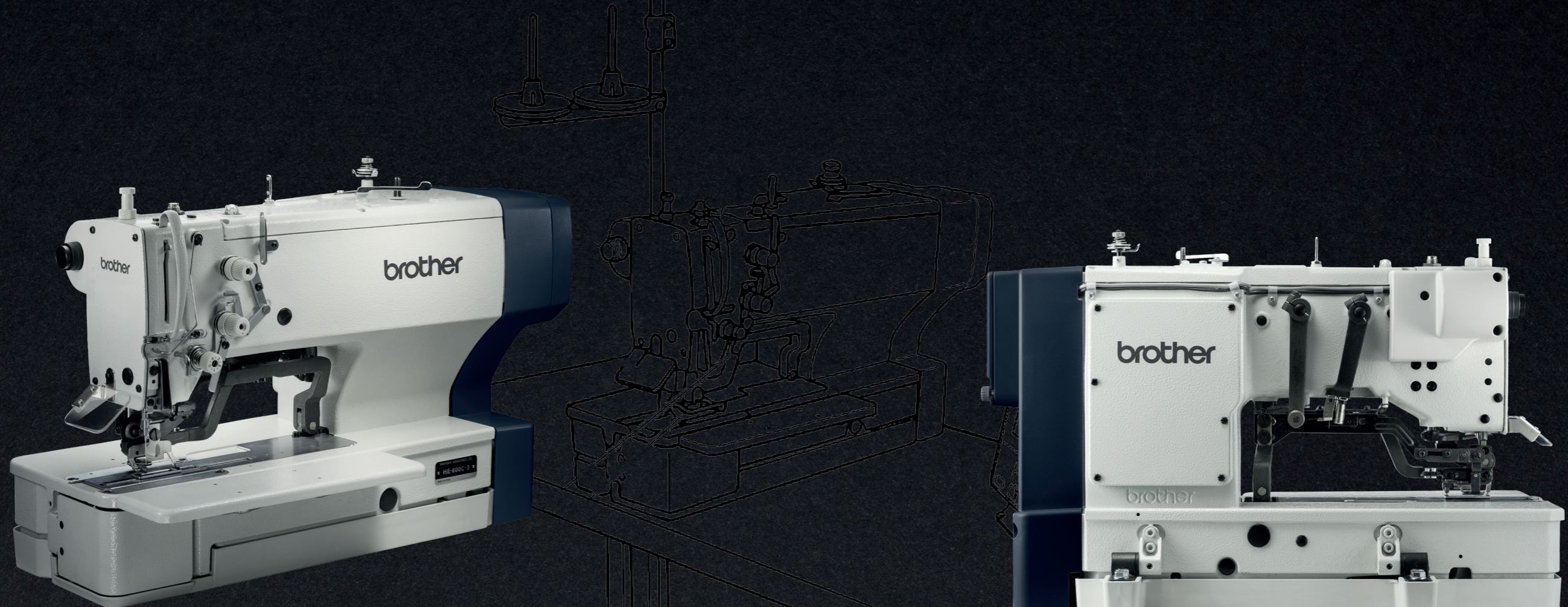

Electronic direct drive lockstitch button holer

High quality sewing due to modified parts and program. High productivity due to double cutting function. Reduction of disposition of thread ends. Productivity improvement by IoT.

High productivity due to double cutting function

It enables double cutting during various size of button hole sewing and gives you high productivity without any changing time of cutters. High cost performances and productivities can be expected.

Easy positioning for sewing

The presser foot lifter is driven by a pulse motor, so that the height can be adjusted as desired. This makes insertion and removal of the material easier and reduces working fatigue.

Specifications

Max. sewing speed	4,000 sti/min
Zigzag mechanism	Pulse motor
Feed mechanism	Pulse motor
Presser foot lifter mechanism	Pulse motor
Cutter mechanism	Double position solenoid
Lower thread holding device	Standard equipment
Bobbin presser	Standard equipment
Standard pattern shapes	21 types
No. of sewing programs storable	50
Max. No. of stitch/program	999 stitches
Data storage method	SD card (No guarantees of operation can be given for any media.)
Power supply	Single-phase: 100V ^{*1} Three-phase: 200V

^{*1} Transformer box is necessary for single - phase 100V

Model overview

	Application	Lower thread holding device	Presser foot lifter amount
HE-800C-2	Woven articles such as shirts, blouses, work clothes and ladies attire	Standard equipment	Max. 13mm (adjustable)
HE-800C-3	Knitted article such as underwear, sweaters, cardigans and jerseys	Standard equipment	Max. 13mm (adjustable)



Eyelet Buttonhole

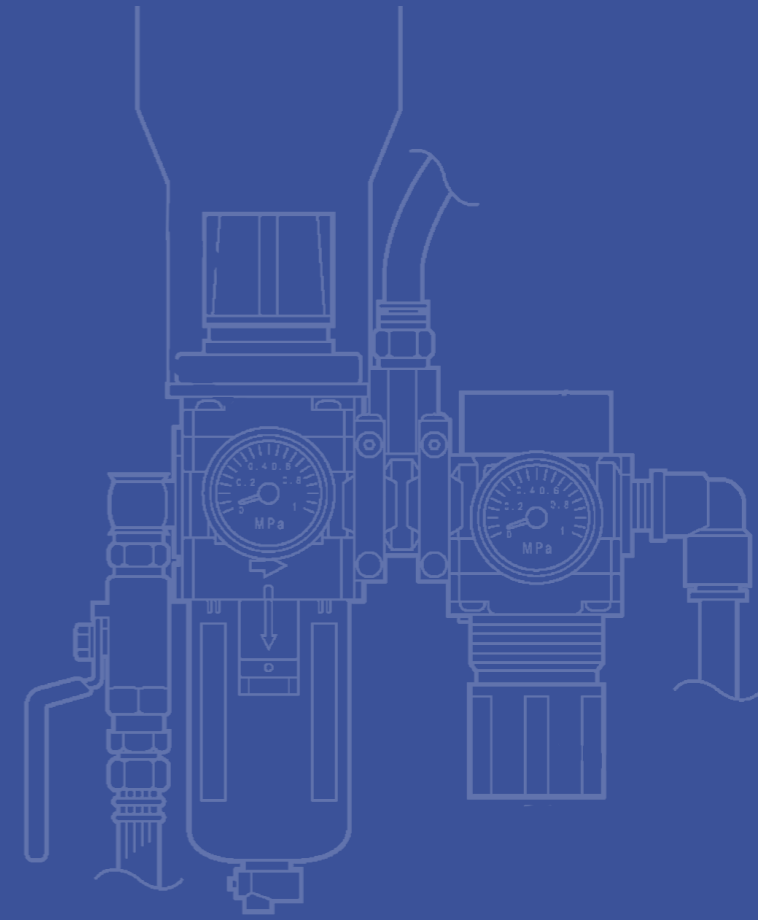
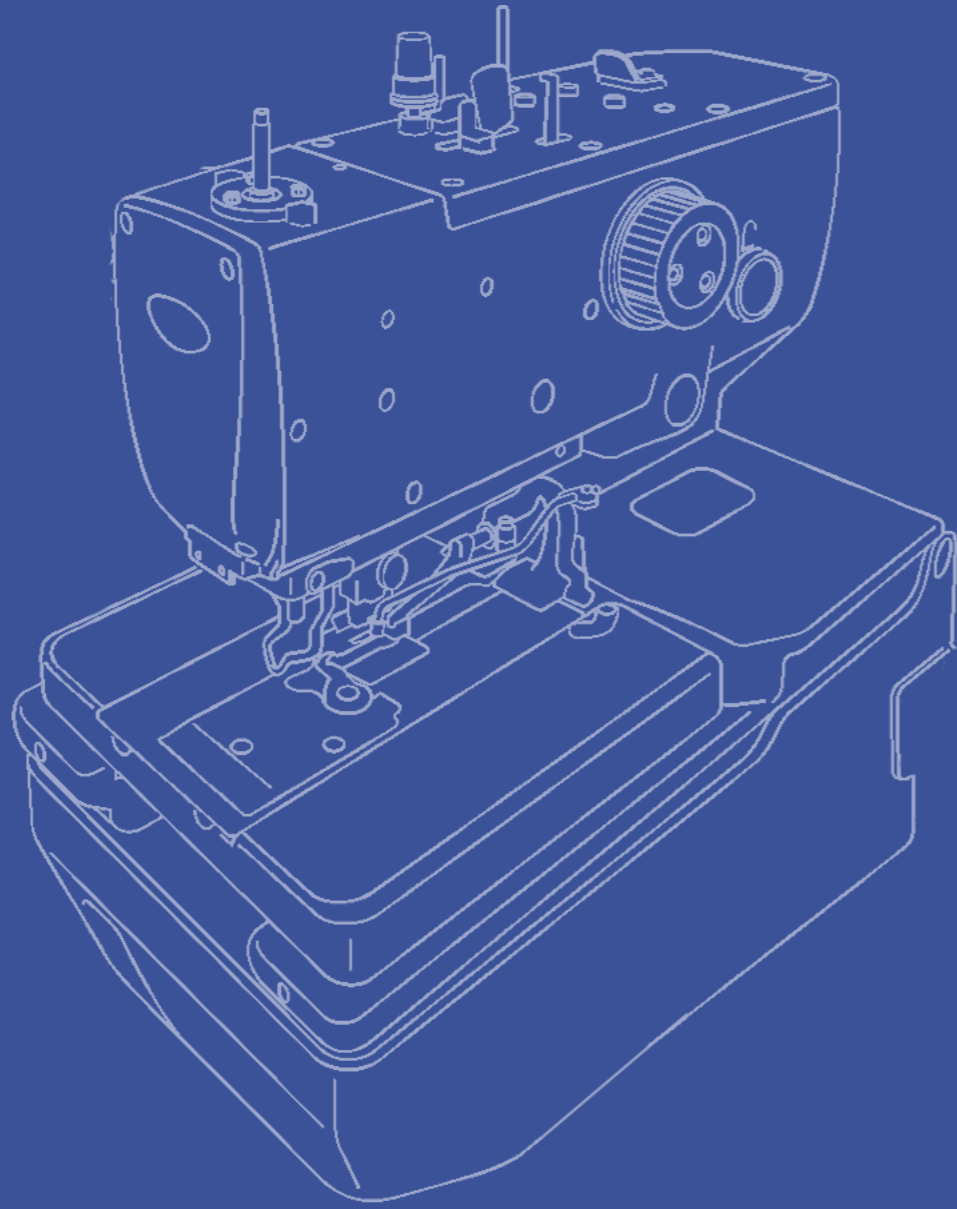

This new design further improves the longstanding reliability and excellent performance of the Brother eyelet button holer. It can be used for various items from casual items to formal items.

RH-982A



Electronic eyelet button hole machine

This new design further improves the longstanding reliability and excellent performance of the Brother eyelet button holer. It can be used for various items from casual items to formal items.

The world's top-class sewing speed 2,500 sti/min enhances productivity

As with the previous model, the optimum structure for high-speed drive is adopted, achieving a maximum sewing speed of 2,500 sti/min. In addition, the patented rigidity around the needle and the servo control of the feed mechanism and needle bar rotation mechanism provide for improved cycle time.

Large work space providing easier of operation

The arm pocket of 120 mm depth gives a sufficient space, enabling smooth setting of material. The arm shape provides a good view of the needle area, allowing operators to observe the sewing operation. It is suited even for vertical button holes and hip pocket parts. The newly equipped LED light is provided as standard and helps provide better viewing when placing fabrics or garments.

Specifications

Sewing speed	1,000 - 2,500 sti/min
Stitch pitch	0.5 - 2.0 mm
Zigzag width	1.5 - 5.0 mm (Up to 4.0 mm in mechanical, up to 5.0 mm with zigzag width compensation)
Taper bartack length	0 - 20 mm
Starting method	Foot switch (Two-pedal type), Hand switch (Two-lever type)
Feed mechanism	Intermittent feed by 3 pulse motors (X, Y, 0)
Needle	D0x558 Nm 80 - Nm120 (SCHMETZ)
Safety equipment	Emergency stop function and built-in automatic stopping device activated by safety circuit in case of trouble
Upper shaft motor	AC servo motor 550W
Air pressure	Main regulator: 0.5 Mpa, Hammer pressure regulator: 0.4MPa
Air consumption	43.2 l/min. (8 cycles/min.)
Weight	Machine head: Approx. 120 kg., Operation panel: Approx. 0.6 kg., Control box: 14.2 - 16.2 kg (depending on the destination)
Power supply	Single phase 100V/200V, 3-phase 200V/220V/ 380V/400V, 400V A

Model overview

	Thread trimmer	Height of work clamp	Length of work clamp (other sizes available as option)	Length of hammer (other sizes available as option)
RH-982A-00	-	12mm standard (Available up to 16mm)	30mm	22mm
RH-982A-01	Long thread cut	12mm standard (Available up to 16mm)	30mm	22mm
RH-982A-02	Short thread cut	16mm	30mm	24mm



Unison Feed

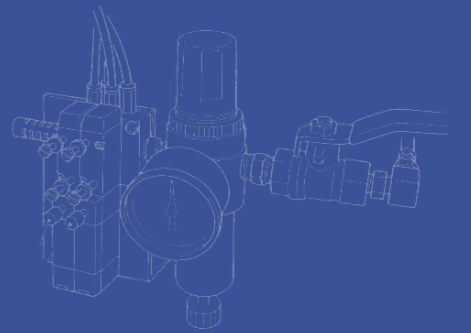
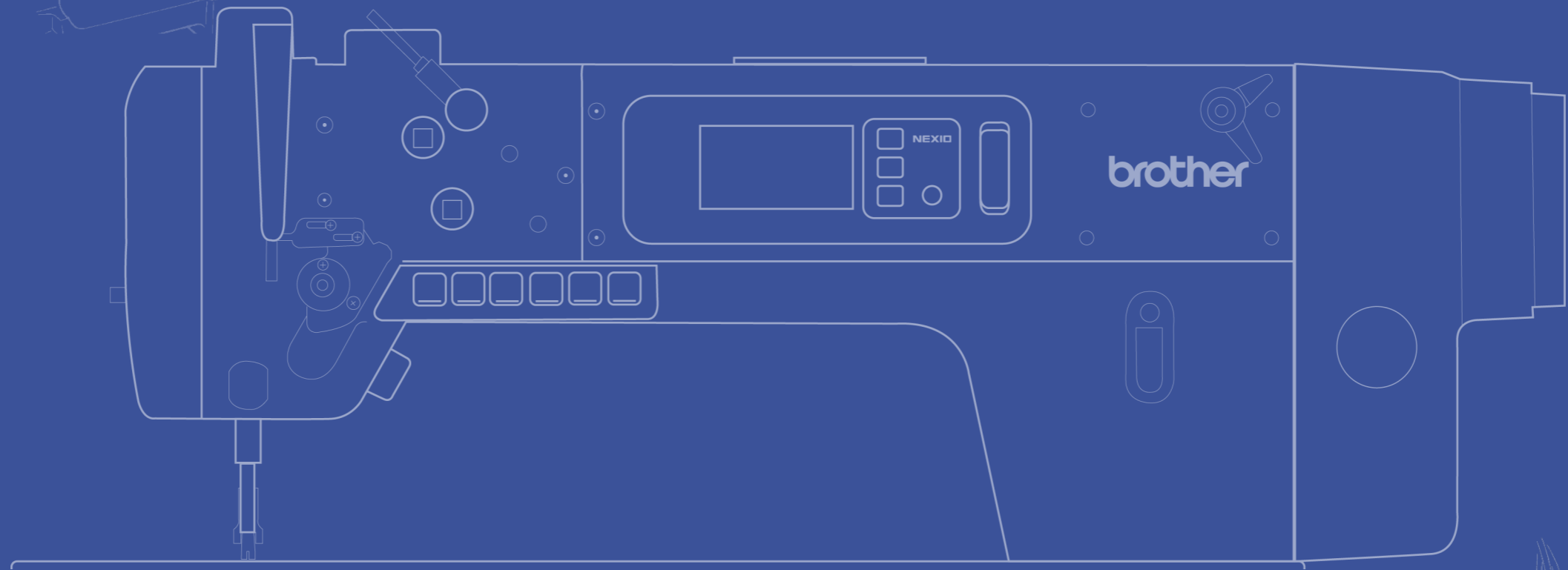
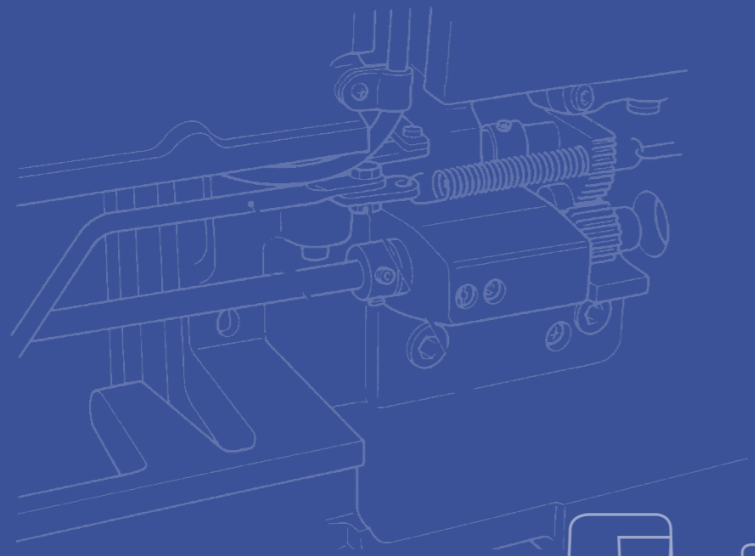

The new brother electronic digital unison feed machine is the result from more than 110 years of experience in innovation in industrial sewing machine manufacturing.

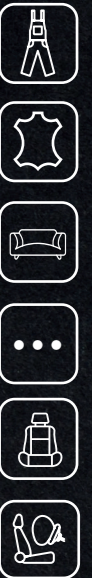
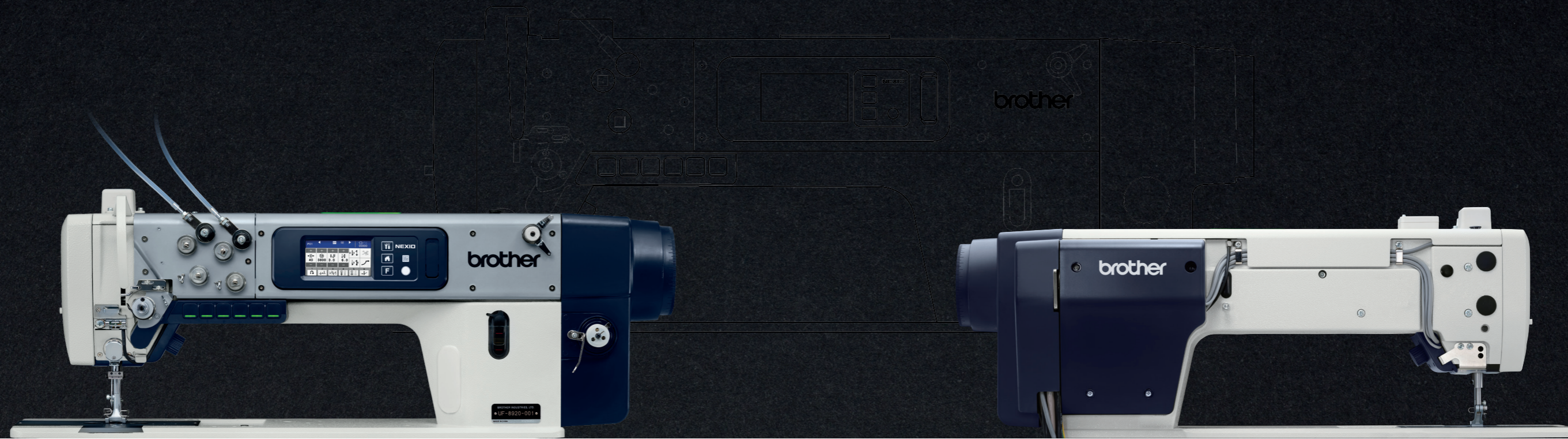

Single needle, direct drive, flat-bed, unison-feed machine with thread timer

Wide arm bed and digitized numerical management are standard. This is the new global standard of Brother's unison-feed sewing machines. Panels and buttons can be customized to the customer's needs for user-friendly operation.

Digitizing adjustment for enhanced sewing reproducibility

Thread tension, alternating presser foot movement, the presser bar pressure, feed pitch and the sewing speed can now be digitalized. Adjustments that used to depend on human senses can now be set numerically with more precision, and identical results on different machines. A upper thread holding device is equipped as standard, it can be set to maintain the upper thread in the back of the fabric at the beginning of sewing.

Large fabric is easy to handle due to its longer arm bed

The 400mm longer arm bed can easily handle large fabrics without stress. Two highly illuminated LED lights are installed to help improve the operator's work efficiency.

Model overview

	Max. sewing speed	Bobbin winder	Skip-stitch device
UF-8910-000 Standard	3,800 sti/min	-	-
UF-8910-001 Deluxe	3,800 sti/min	Electric bobbin winder	-
UF-8910-101 Premium	3,800 sti/min	Electric bobbin winder	Standard

Specifications

Max. back tacking speed	2,000 sti/min
Max. stitch length	9mm
Presser foot height	20mm
Max. interaction lift stroke	9mm
Presser bar pressure	70~125N
Needle thread tension	0.7~9.5Nm
Arm pocket size	400mm
Hook size	28mm
Needle bar stroke	40mm
Needle (DBx1 · DPx5)	134x35 Nm130 (#21) Nm125~180 (#20~#24)
LED light	LED for sewing area and arm pocket are standard equipment
Number of programs	15 programs (each program has 20 steps)
Number of patterns	9 ~ 50 patterns*1
Motor	AC servo motor (1kW)
Power	Single phase, 3-phase: 200V-240V

*1 Varies depending on the number of stitches per pattern and the total number of needles.





Twin needle, direct drive, flat-bed, unison-feed machine with thread timer

Wide arm bed and digitized numerical management are standard. This is the new global standard of Brother's unison-feed sewing machines. Panels and buttons can be customized to the customer's needs for user-friendly operation.

Digitizing adjustment for enhanced sewing reproducibility

Thread tension, alternating presser foot movement, the presser bar pressure, feed pitch and the sewing speed can now be digitalized. Adjustments that used to depend on human senses can now be set numerically with more precision, and identical results on different machines. A upper thread holding device is equipped as standard, it can be set to maintain the upper thread in the back of the fabric at the beginning of sewing.

Large fabric is easy to handle due to its longer arm bed

The 400mm longer arm bed can easily handle large fabrics without stress. Two highly illuminated LED lights are installed to help improve the operator's work efficiency.

Model overview

	Max. sewing speed	Bobbin winder	Skip-stitch device
UF-8920-001 Deluxe	3,400 sti/min	Electric bobbin winder	-

Specifications

Max. back tacking speed	2,000 sti/min
Max. stitch length	9mm
Presser foot height	20mm
Max. interaction lift stroke	9mm
Presser bar pressure	70~125N
Needle thread tension	0.7~9.5Nm
Arm pocket size	400mm
Hook size	28mm
Standard twin needle gauge	10mm
Min. needle gauge	3mm
Max. needle gauge	35mm
Needle bar stroke	40mm
Needle (DBx1 · DPx5)	134x35 Nm130 (#21) Nm125~200 (#20~#25)
LED light	LED for sewing area and arm pocket are standard equipment
Number of programs	15 programs (each program has 20 steps)
Number of patterns	9 ~ 50 patterns ^{*1}
Motor	AC servo motor (1kW)
Power	Single phase, 3-phase: 200V-240V

^{*1} Varies depending on the number of stitches per pattern and the total number of needles.



Single Needle

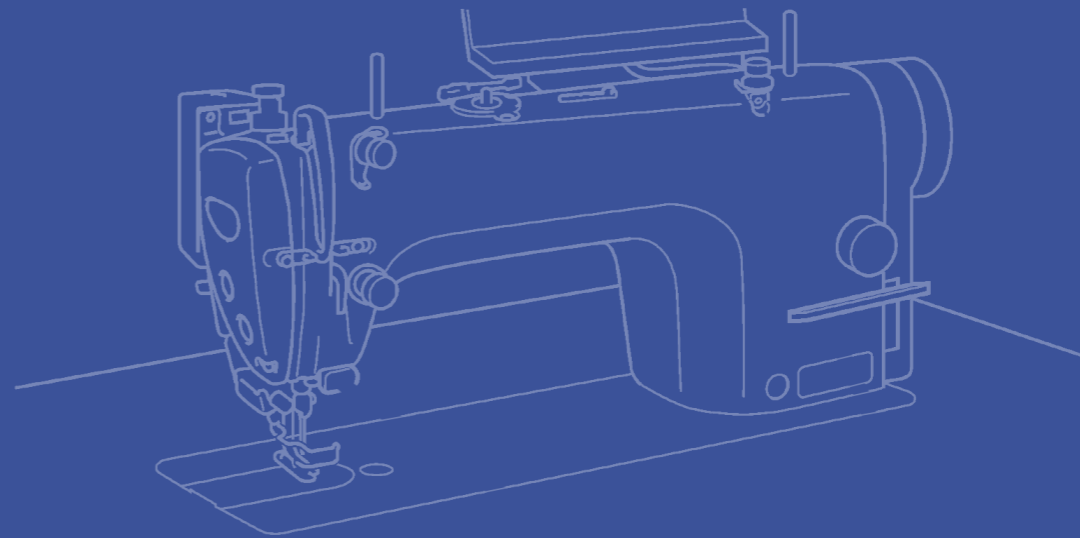
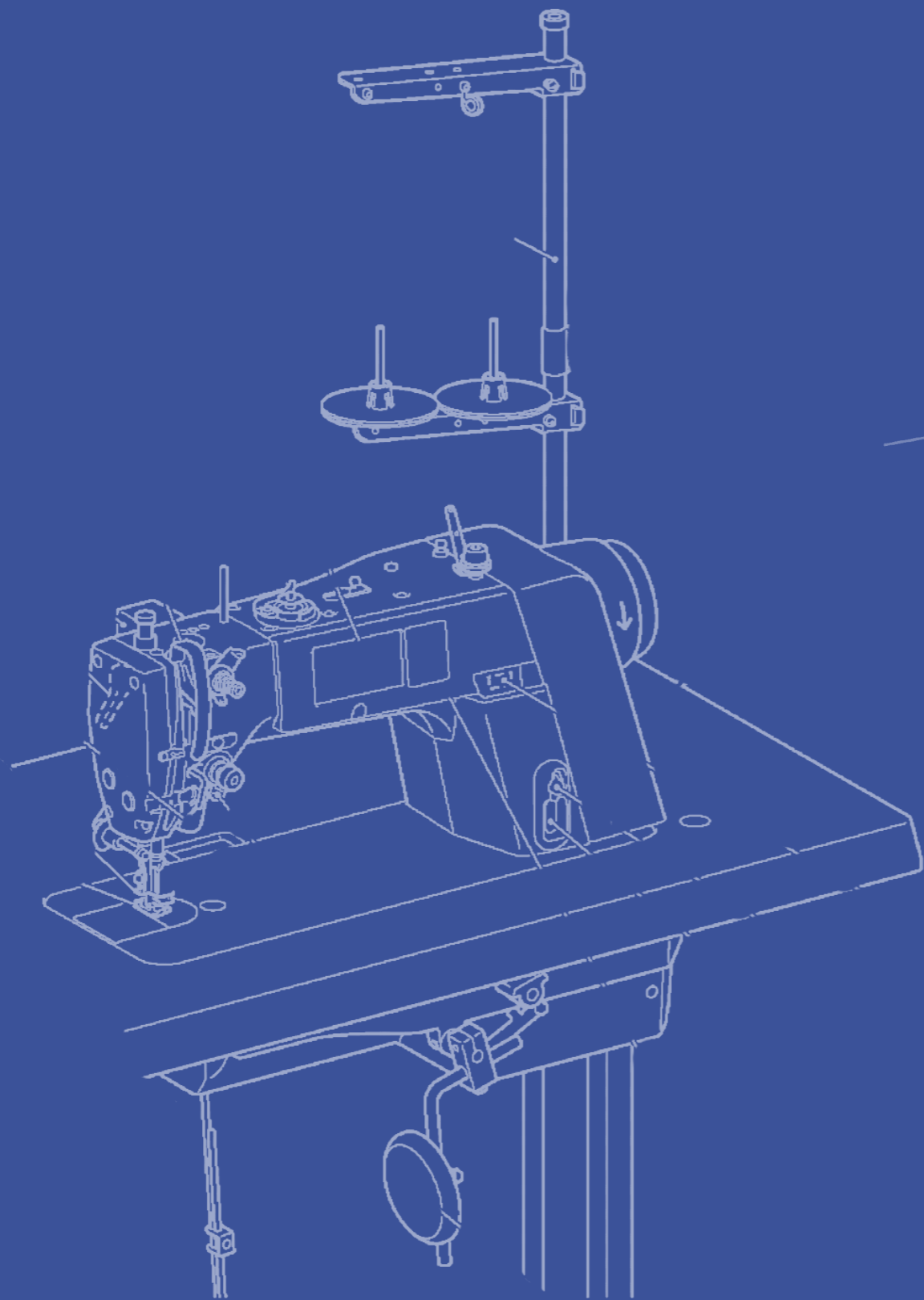

Since its inception in 1908, Brother has been at the forefront of product innovation, dedicated to delivering superior and innovative sewing technology to our customers. While these innovative changes have now become the industry standard, our never ending spirit of challenge and innovation inherited from our ancestors have helped us surmount many challenges in the marketplace and continue striving for product excellence.

S-7780A

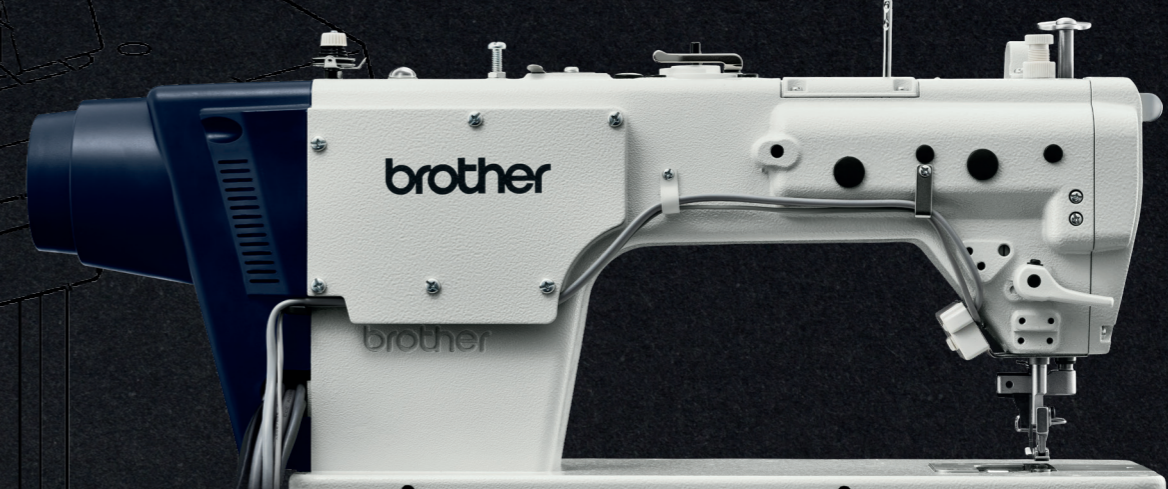

Single needle direct drive lock stitcher with side cutter, electronic feeding system and thread trimmer

Sewing and cutting of fabric can be performed simultaneously, and the thread trimming function at the end of sewing contributes to improved productivity. Equipped with “DigiFlex Feed”, an electronic digital feed mechanism that has a reputation for high quality in the market.

Good response, comfortable sewing by the direct drive motor

Compared to conventional under-table servo motor control, the pulse motor control makes starting and stopping of sewing quicker. The direct drive mechanism provides reliability with the unique built-in direct drive motor developed by Brother.

Wide waste opening

This keeps the top of the work table clean at all times and lets the next operation proceed without concern. In addition, when not using the side cutter feature, the sewing machine can be used as a common, straight, lock stitcher by attaching a needle plate cover.

	2.5mm (3/32)	3.2mm (1/8)	4.0mm (5/32)	4.8mm (3/16)	6.4mm (1/4)	9.5mm (3/8)
Material guide						
Feed dog						
Needle plate	2.5mm	3.2mm	4mm	4.8mm	6.4mm	9.5mm
Presser foot Assy						

Specifications

Lubrication type	Minimum lubrication
Application	Medium materials
Max. sewing speed	4,500 sti/min
Max. stitch length	4mm
Feed system	Bottom-feed
Presser foot height	Presser bar lifter: 5mm, Knee lifter: 13mm
Needle bar stroke	31mm
Needle(DBx1)	#11-#18 (Nm75-110)
Max. thickness of the material to be cut	4mm
Quick back device	Standard equipment
Thread presser	Standard equipment
Weight	37kg
Power	Single phase: 110V* / Single phase, 3-phase: 200V-230 V / Max. electric power consumption 550VA

*1 The transformer is required.



S-7220D



Single Needle direct drive needle feed lock stitcher with thread trimmer

The needle feed lock stitcher is suitable for the sewing of slippery materials or sewing of multiple layers of material. It helps to prevent uneven material feeding to further meet the highest quality sewing standard while requiring less skill.

Enhanced electronic design

We adopted the control circuit board design which has been proven effective in other models and strengthened the ability to cope with the voltage fluctuations. In addition, vibration resistance is improved, and you can use it safely in various environments.

Needle breakage prevention function

When reverse stitching is carried out using the quick back switch on standard straight lock stitcher machines, needle breakage may occur. With thorough analysis of its cause, the function of preventing the needle breakage has been introduced.

Specifications

Lubrication type	Minimum lubrication
Start back tacking and continuous back tacking speed	220 - 3,000 sti/min
End back tacking speed	1,800 sti/min
Presser foot height	Presser bar lifter:6mm, Knee lifter:16mm
Arm pocket size	Width:300mm, Height:120mm
Machine head drive	Direct drive mechanism
Motor	AC servo motor (450W)
Weight Machine head	46kg
Weight Control box	7.7kg
Power	Single phase: 110V ^{*1} / Single phase, 3-phase: 200V-230V Max. electric power consumption 500VA

^{*1} The transformer is required.

Model overview

	Application	Max. sewing speed	Max. stitch length	Needle bar stroke	Needle (DB×1•DP×5)	Feed dog height
S 7220D-403	Medium materials	5,000 sti/min ^{*1}	4.5mm	33mm	#11~#18	1.0mm
S 7220D-405	Heavy materials	4,000 sti/min ^{*2}	5.5mm	35mm	#19~#22	1.2mm

^{*1} When sewing at speeds of 4,000 sti/min or higher, set the stitch length to 3.5mm or less.
^{*2} When sewing at speeds of 3,000 sti/min or higher, set the stitch length to 4.5mm or less.



S-7300A



Single needle direct drive lock stitcher with electronic feeding system and thread trimmer

The world's first lock stitch sewing machine which adopts the Electronic Feed Control directly connected with a stepping motor. Next-generation lock stitch machine, which establishes the new standard, has been born.

World's first digital feed control directly connected with a stepping motor

Horizontal feeding system is world's first computerized for single needle lock stitch sewing machine. The feed motion can be changed with one touch of a button to provide

best sewing quality for various materials. Furthermore, the sewing stitch length can be digitalized, stabilizing the stitches.

Specifications

Max back tacking speed	3,000 sti/min
Presser foot height	Presser bar lifter: 6mm, knee lifter: 16mm
Weight	34,5kg
Motor	AC servo motor
Power supply	100V-110V, 200-230V, 380-400V under 450VA

Model overview

	Lubrication type	Application	Max. sewing speed	Thread trimming mechanism	Max. stitch length	Needle bar stroke	Needle	Height of feed dog
-903	Minimum	Medium materials	Max. 5,000 sti/min	Single action trimming mechanism	5mm	31mm	#11-#18 (Nm75-110)	0.8mm
-905	Minimum	Heavy materials	Max. 4,500 sti/min	Single action trimming mechanism	Max. 7mm	35mm	#19-#22 (Nm120-140)	1.2mm
-933P	Semi dry	Medium materials	Max. 5,000 sti/min	Double action trimming mechanism	5mm	31mm	#11-#18 (Nm75-110)	0.8mm
-903P	Minimum	Medium materials	Max. 5,000 sti/min	Double action trimming mechanism	5mm	31mm	#11-#18 (Nm75-110)	0.8mm
-905P	Minimum	Heavy materials	Max. 4,500 sti/min	Double action trimming mechanism	Max. 7mm	35mm	#19-#22 (Nm120-140)	1.2mm



S-7250A



Single needle direct drive lock stitcher with electronic feeding system and thread trimmer

Equipped the innovative DigiFlexFeed System for high productivity simple and easy-to-use standard lock stitch machine with selected functions, for example, reduces needle breakage, puckering and materials slippage with DFF, elimination of oil stains due to the adaption of the sealed type oil pan, productivity improvement management utilizing IoT.

Good response, comfortable sewing by the direct drive motor

Fabric can be feed at an appropriate timing so that needle won't break even during thick material sewing. Change from mechanical control to stepping motor control by equipped DFF. Compared to conventional mechanical control, the stepping motor control makes

the response of reverse sewing quicker and reduces needle breakage. Equipped with needle prevent breakage function while reverse sewing. Sensing needle position and controlling proper feed timing that prevent from unreasonable reverse sewing as needle breaks automatically.

Model overview

	Application	Max. sewing speed	Max. stitch length	Thread trimming mechanism	Needle bar stroke	Needle (DBX1-DPX5)	Height of feed dog
-703	Medium materials	5,000 sti/min	5mm	Single action trimming mechanism	31mm	#11-#18 (Nm75-110)	0.8mm
-705	Heavy materials	4,000 sti/min	Max. 7mm (default setting: 5mm)	Single action trimming mechanism	35mm	#19-#22 (Nm120-140)	1.2mm
-703P	Medium materials	5,000 sti/min	5mm	Double action trimming mechanism	31mm	#11-#18 (Nm75-110)	0.8mm
-705P	Heavy materials	4,000 sti/min	Max. 7mm (default setting: 5mm)	Double action trimming mechanism	35mm	#19-#22 (Nm120-140)	1.2mm

Specifications

Lubrication	Minimum lubrication
Max. back tacking speed	3000 sti/min
Presser foot height	Presser bar lifter: 6mm Knee lifter: 13mm
Weight	35kg
Motor	AC servo motor
Power	100-110V(*2), 200V-230V, 380V-400V(*2) under 450VA

*2 The transformer is required.



Twin Needle

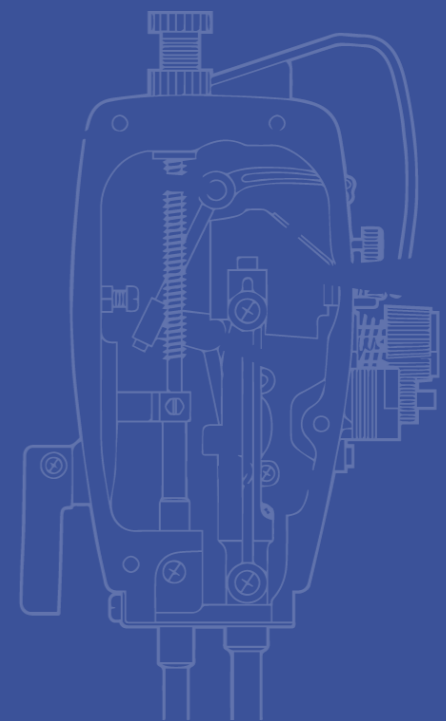
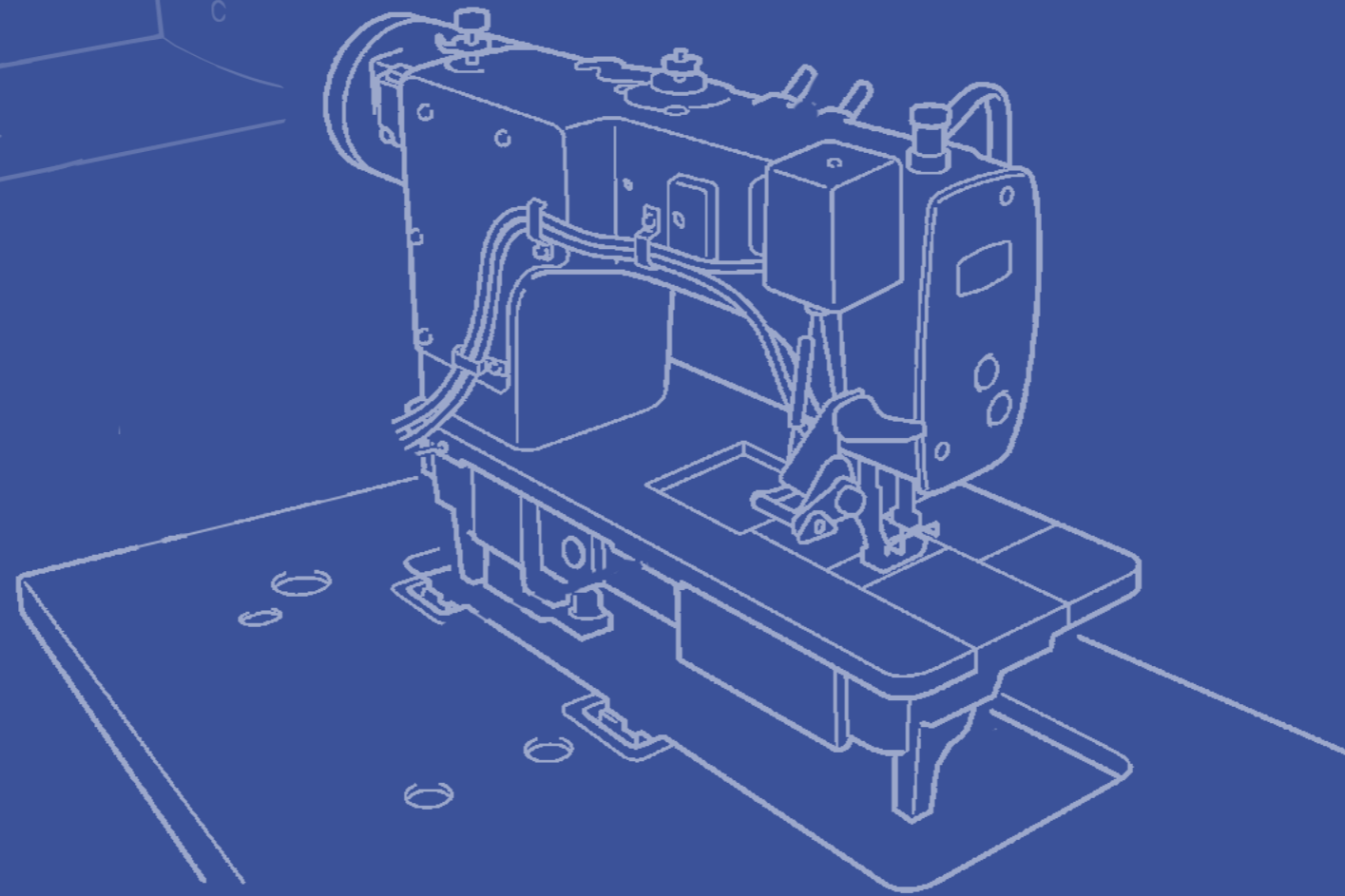
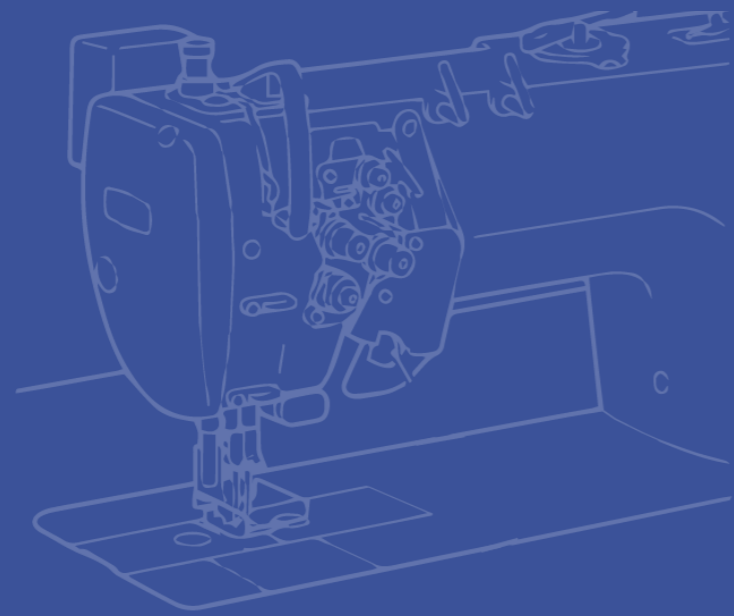

The needle breakage prevention function which prevents the needle breakage when reverse stitching is carried out with the quick back switch. This contributes to the improvement of the operator's work efficiency.

T-8420C T-8450C T-8720C

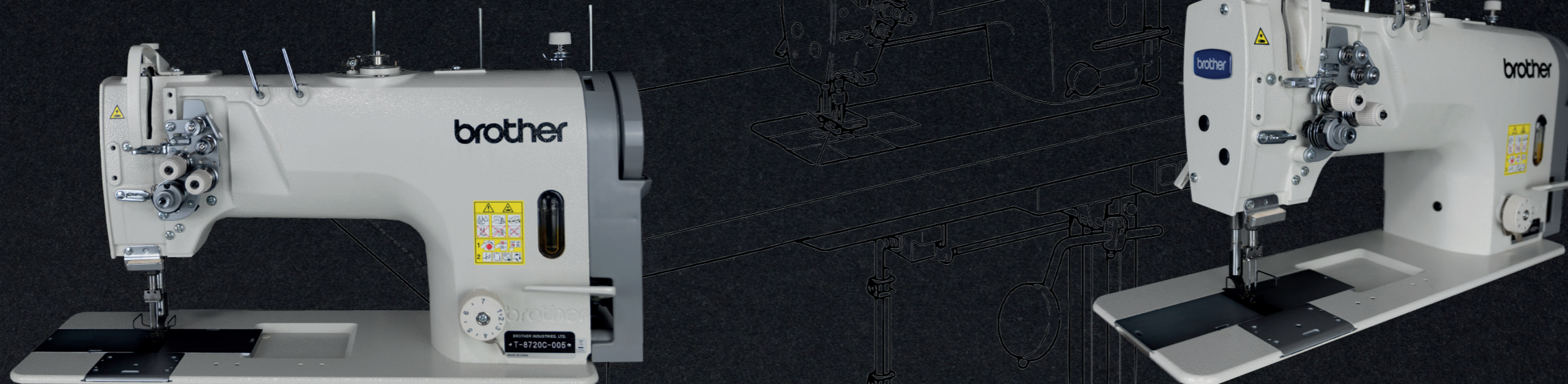

Twin needle lock stitcher

A micro-adjustable type floating presser foot, which can be slightly lifted to set according to sewing materials, is equipped as standard. This device is ideal for controlling presser foot floating in materials that stretch easily and materials with long pile.

Prevents birds nests

Stabilized motor stop position at the time of thread trimming reduces the bobbin racing. This prevents the birds nest. It is a big advantage when sewing the light materials.

Easy Gauge part replacement

Cam adopted in the lateral position adjustment mechanism for the rotary hook base allows easy fine adjustments for clearance between needle and rotary hook point can easily be made, which greatly increases the efficiency of replacing gauge parts. Furthermore, a needle drop correction function (sideways) is provided, so that the needle drop position can still be adjusted to the center of the needle hole even if using commercially-available gauge parts.

Specifications

Stitch	Twin needle lock stitch
Start backtacking and continuous backtacking speed	250 ~1,800 sti/min
End backtacking speed	1,000 sti/min
Arm pocket size	120mm x 264mm
Quick back device	Standard equipment
Thread wiper	None
Thread trimmer type	None
Machine head drive	Direct drive mechanism
Motor	AC servo motor (550W)
Weight Machine head	47kg
Weight Control box	7.7kg
Power	Single-phase: 110V ^{*1} , 3-phase: 200V-230V Max. electric power consumption 500VA

^{*1} The transformer is required

Model overview

	Direct Drive	Lock stitch	2-Needle	Split needle bar	Bottom feed	Needle feed	Standard hook	Double hook	Thread trimmer	Thread wiper	Quick back device
T-8420C	-	○	○	-	○	○	○	-	-	-	-
T-8450C	-	○	○	○	○	○	○	-	-	-	-
T-8720C	-	○	○	-	○	○	-	○	-	-	-



T-8421D

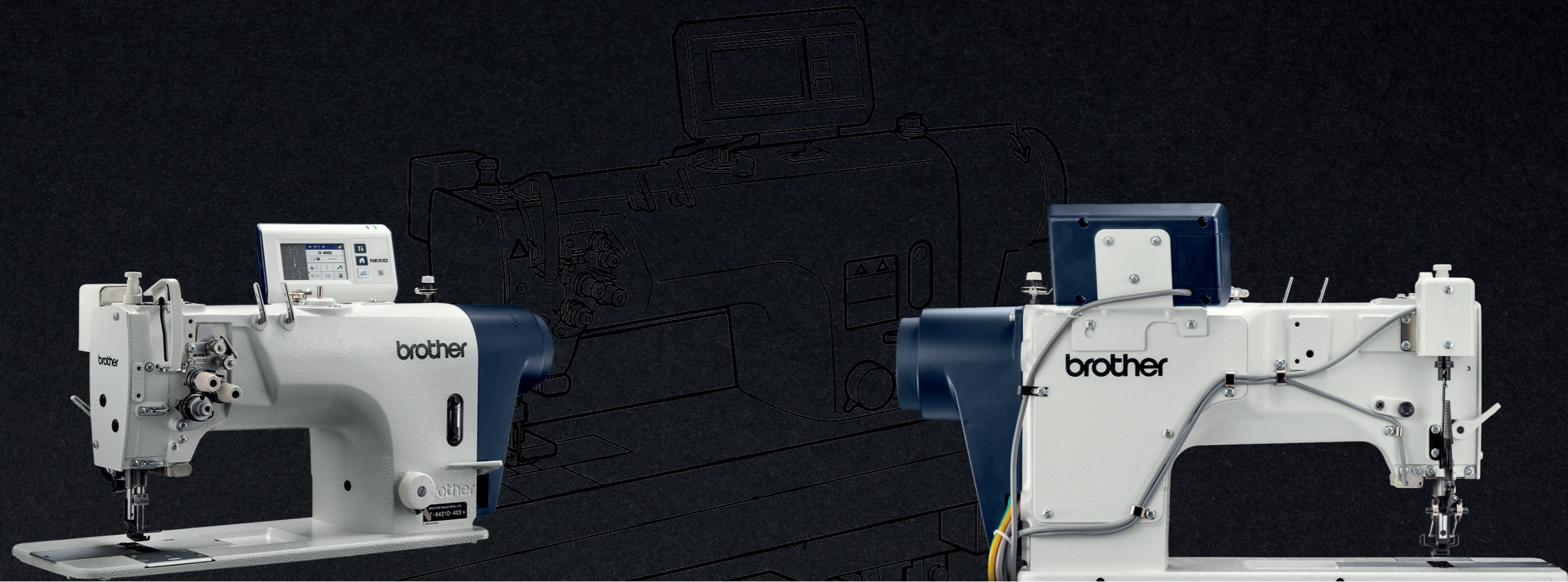

Twin needle direct drive lock stitcher

Machine is equipped with Color LCD touch panel, which improves the usability. The needle breakage prevention function prevents the needle breakage when reverse stitching is carried out with the quick back switch. This contributes to the improvement of the operator's work efficiency.

Reliable sewing with strong needle penetration

Powerful 550W motor outputs large amounts of torque even at slow speeds so that strong needle penetration force can be obtained. This allows accurate sewing of heavy materials and joints. If the needle penetration resistance increases when sewing heavy materials and materials with joints, vibration control (intermittent impact) automatically increases the penetration force.

Further progress based on reliability

Equipped with the Color LCD touch panel, the functionality becomes easier to use. The needle breakage prevention function which prevents the needle breakage when reverse stitching is carried out with the quick back switch. This contributes to the improvement of the operator's work efficiency.

Specifications

Stitch	Twin needle lock stitch
Start backtacking and continuous backtacking speed	250 ~1,800 sti/min
End backtacking speed	1,000 sti/min
Arm pocket size	120mm x 264mm
Quick back device	Standard equipment
Thread wiper	None
Thread trimmer type	None
Machine head drive	Direct drive mechanism
Motor	AC servo motor (550W)
Weight Machine head	47kg
Weight Control box	7.7kg
Power	Single-phase: 110V ^{*1} , 3-phase: 200V-230V Max. electric power consumption 500VA

^{*1}The transformer is required

Model overview

	Lubrication type	Applications	Max. sewing speed	Thread trimmer	Max. stitch length	Presser foot height
-T03	Minimum lubrication	Light and medium materials	4,000 sti/min	-	4mm	7mm



T-8422D T-8722D
T-8452D T-8752D

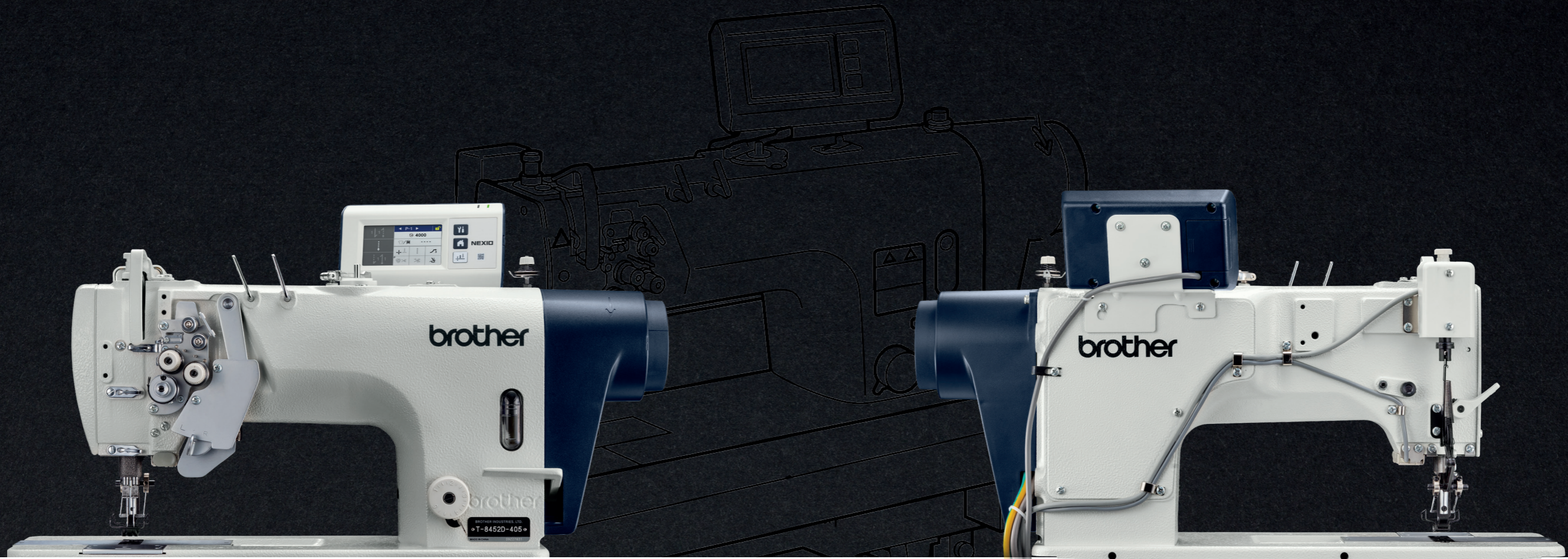

Twin needle direct drive lock stitcher

Machine is equipped with Color LCD touch panel, which improves the usability. The needle breakage prevention function which prevents the needle breakage when reverse stitching is carried out with the quick back switch.

In-house development improves 5 control board reliability furthermore

We adopted the control circuit board design which has been proven effective in other models and strengthened the ability to cope with the voltage fluctuations. In addition, vibration resistance is improved, and you can use it safely in various environments.

User- intuitive color LCD touch panel

The Color LCD touch panel display items with illustrated icons, offering easy user-intuitive operation.

Specifications

Stitch	Twin needle lock stitch
Start backtacking and continuous backtacking speed	250 ~ 1,800 sti/ min
End backtacking speed	1,000 sti/min
Arm pocket size	120mm x 264mm
Quick back device	Standard equipment
Thread wiper	Standard equipment
Thread timer type	Straight / Arc
Machine head drive	Direct drive mechanism
Motor	AC servo motor (550W)
Weight	50kg
Power	Single-phase: 110V 1,3phase: 200V - 230V

Model overview

	Direct Drive	Split needle bar	Bottom feed	Needle feed	Standard hook	Double hook	Thread trimmer*	Thread wiper	Quick back device
T-8422D	○	-	○	○	○	-	○	○	○
T-8722D	○	-	○	○	-	○	○	○	○
T-8452D	○	○	○	○	○	-	○	○	○
T-8752D	○	○	○	○	-	○	○	○	○

*Depending on the subclass, the machines are equipped with arc or straight thread trimming mechanism.



Zigzag

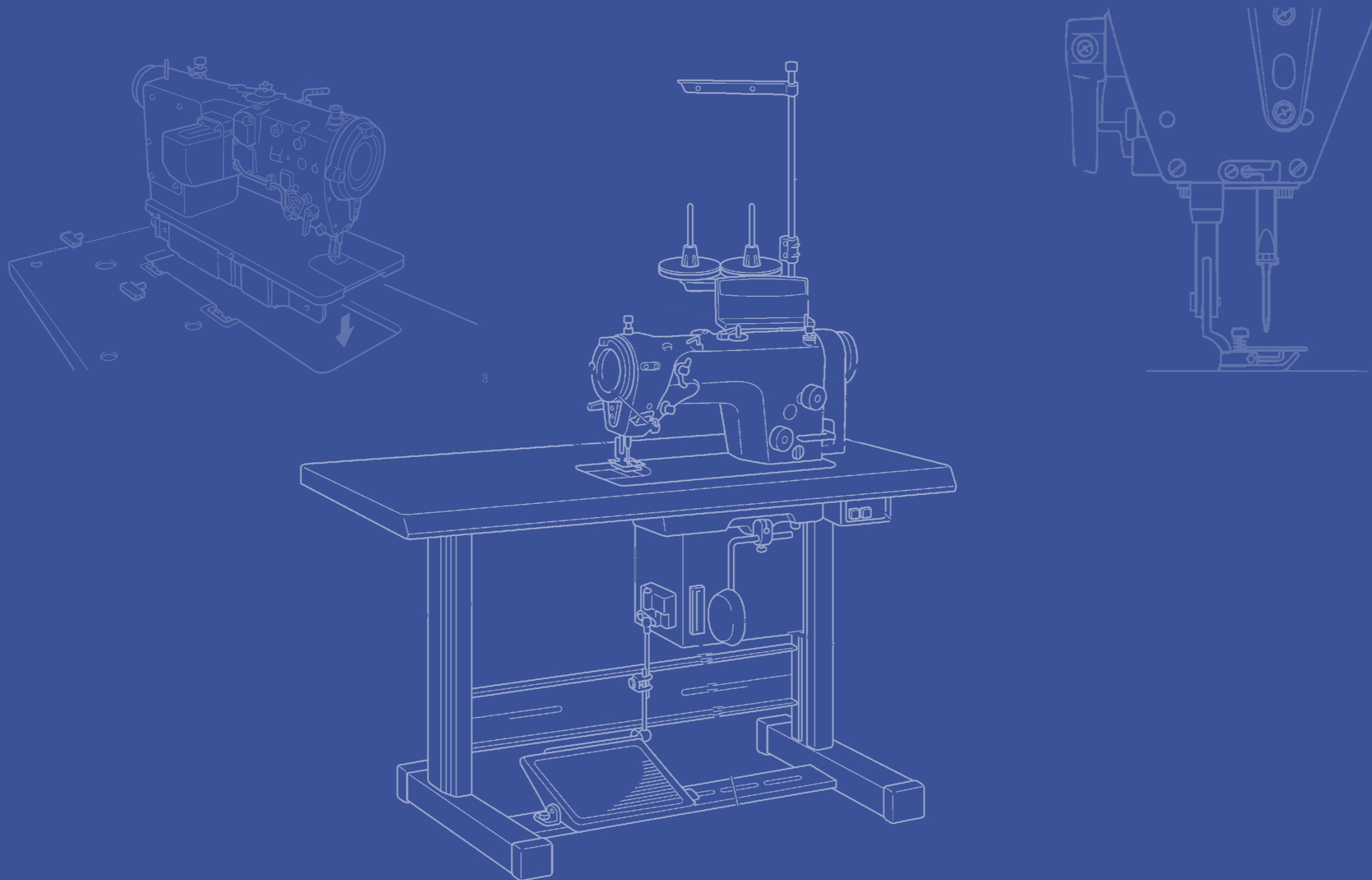

Equipped with the color LCD touch panel, it becomes easy to set various sewing patterns with intuitive operation of the display. The servo motor control greatly improves the stitch pattern accuracy contributing to the improvement of sewing quality.

Z-8550B

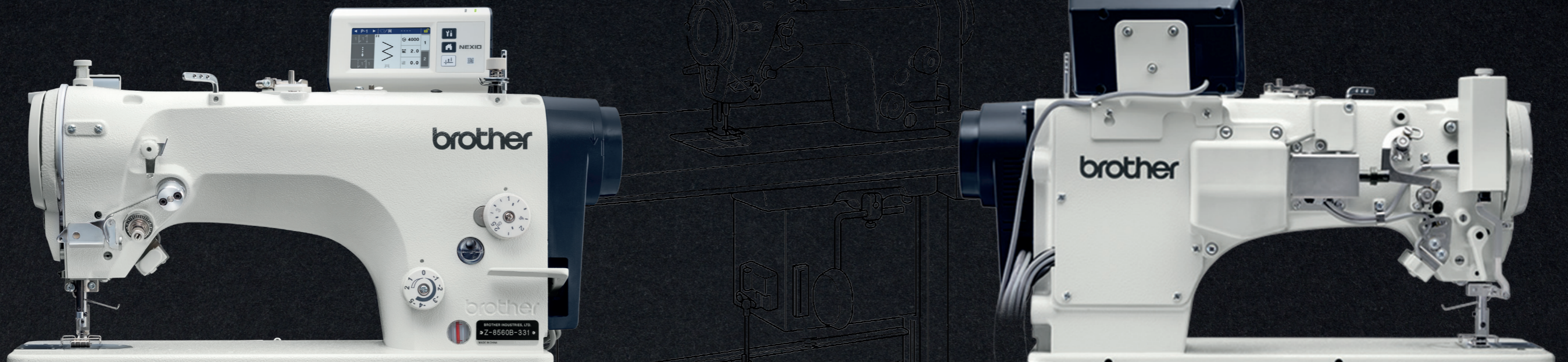

Electronic direct drive Zigzag lock stitcher

Equipped with the color LCD touch panel, it becomes easy to set various sewing patterns with intuitive operation of the display. The servo motor control greatly improves the stitch pattern accuracy contributing to the improvement of sewing quality.

User-intuitive color LCD display touch panel

The color LCD display touch panel display items with illustration icons, offering easy user-intuitive operation. There are two types of operator panel display. Both the detailed home screen and quick home screen are easy to use without concern for panel operation.

High sewing quality achieved by electronic control, the pulse motor control with servo control is adopted for the zigzag mechanism, The needle moves perpendicular to the material so that needle deflection or position slippage does not occur even at high speed sewing.

Productivity improvement with IoT capabilities. This model is IoT applicable. The visualization by connecting sewing machine and computer technology enables the customer to analyze, manage processes and speed up productivity improvement and maintenance work.

Model overview

	Thread trimmer	Backtack / Condensed stitch device	Upper thread feeding device
Z-8550B-031	-	-	-
Z-8550B-A31	-	○	-

Specifications

Stitch form	Zigzag stitch
Max. sewing speed	5,000 sti/min ^{*1}
Max. zigzag width	10mm ^{*2}
Lubrication type	Semi-dry
Application	Light materials/Medium materials
Presser foot height	Manual: 6mm/Knee:10mm
Presser foot pressure	10-35N
Needle bar stroke	33mm
Needle	134SUK Nm70/10
Max. feed amount	4mm
Height of feed dog	1mm
Arm pocket width	300mm
Arm pocket height	121.5mm
Sewing pattern	8 types, 14 patterns built-in ^{*3}
LED	Standard equipment
Motor	AC servo motor (450W)
Power	Single phase, 3-phase 200V-230V / Max. electric power consumption 400VA

^{*1} The factory setting is 4,000sti/min. The speed may be limited by some sewing patterns or settings of zigzag width
^{*2} The factory setting is 8mm. To make it 10mm, gauge parts and a stopper for the size are necessary (optional).
^{*3} Custom patterns can be added up to 99 patterns with a total of 49,500 stitches, 500 stitches or less per pattern.

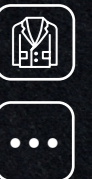

Z-8560B



Electronic direct drive Zigzag lock stitcher with thread trimmer

Equipped with the color LCD touch panel, it becomes easy to set various sewing patterns with intuitive operation of the display. The servo motor control greatly improves the stitch pattern accuracy contributing to the improvement of sewing quality.

User-intuitive color LCD display touch panel

The color LCD display touch panel display items with illustration icons, offering easy user-intuitive operation. There are two types of operator panel display. Both the detailed home screen and quick home screen are easy to use without concern for panel operation.

Productivity improvement with IoT capabilities. This model is IoT applicable. The visualization by connecting sewing machine and computer technology enables the customer to analyze, manage processes and speed up productivity improvement and maintenance work.

High sewing quality achieved by electronic control, the pulse motor control with servo control is adopted for the zigzag mechanism, The needle moves perpendicular to the material so that needle deflection or position slippage does not occur even at high speed sewing.

Model overview

	Thread trimmer	Backtack / Condensed stitch device	Upper thread feeding device
Z-8560B-431	○	○	○

Specifications

Stitch form	Zigzag stitch
Max. sewing speed	5,000 sti/min ^{*1}
Max. zigzag width	10mm ^{*2}
Lubrication type	Semi-dry
Application	Light materials/Medium materials
Presser foot height	Manual: 6mm/Knee:10mm
Presser foot pressure	10-35N
Needle bar stroke	33mm
Needle	134SUK Nm70/10
Max. feed amount	4mm
Height of feed dog	1mm
Arm pocket width	300mm
Arm pocket height	121.5mm
Sewing pattern	8 types, 14 patterns built-in ^{*3}
LED	Standard equipment
Motor	AC servo motor (450W)
Power	Single phase, 3-phase 200V-230V / Max. electric power consumption 400VA

^{*1} The factory setting is 4,000sti/min. The speed may be limited by some sewing patterns or settings of zigzag width
^{*2} The factory setting is 8mm. To make it 1mm, gauge parts and a stopper for the size are necessary (optional).
^{*3} Custom patterns can be added up to 99 patterns with a total of 49,500 stitches, 500 stitches or less per pattern.



Feed off the arm

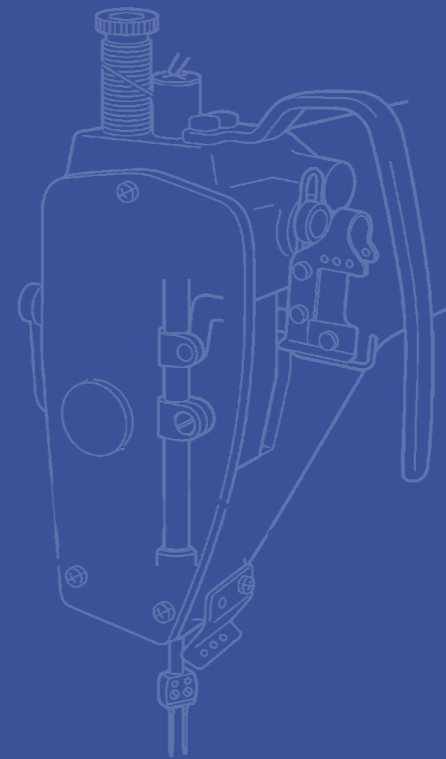
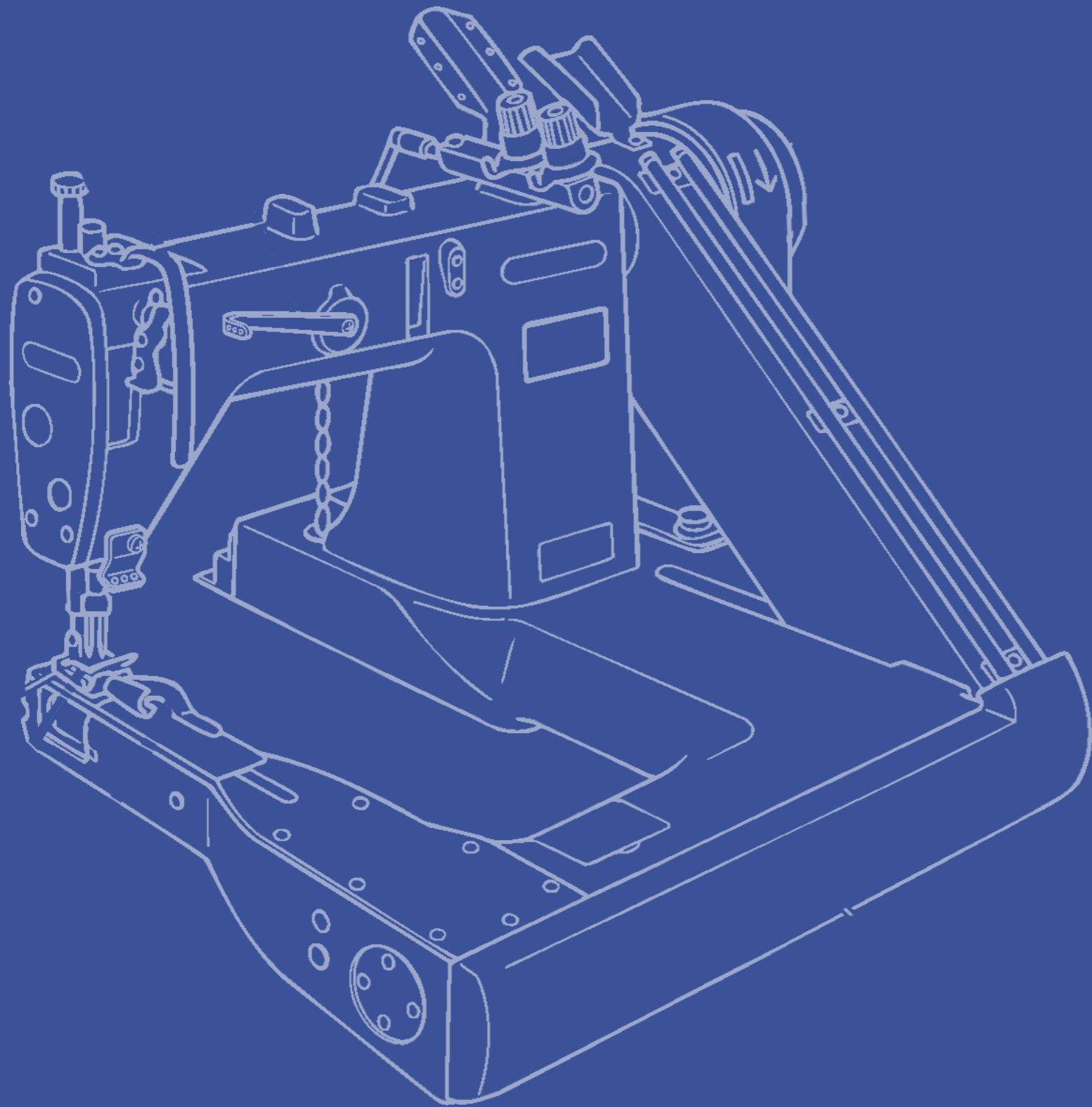

Minimum lubrication system can be realizing clean sewing. Narrow cylinder bed feed off-the-arm double chain stitchers. Ideal for a wide range of materials from shirts to jeans.

DA-927A



Twin Needle feed off the arm double chain stitcher

Minimum lubrication system can be realizing clean sewing. Narrow cylinder bed feed off-the-arm double chain stitchers. Ideal for a wide range of materials from shirts to jeans. Clean sewing with minimum lubrication system, a new knife with highly safe shape, beautiful sewing finishes with new presser mechanism.

Minimum lubrication system can be realizing clean sewing

Minimum lubrication system supplies limited oil only to the needle bar and the upper shaft realizing clean sewing for your valued products.

Rubber puller

For better efficiency rubber puller are available.

Specifications

Lubrication type	Minimum lubrication
Max. sewing speed	4,000 sti/min
Weight	49kg
Size	465mm x 500mm x 340mm
Outer perimeter of cylinder	171mm

Model overview

	Applications	Max. stitch length	Height of presser foot	Needle bar stroke	Needle	Height of feed dog	Presser foot presser
-1	light materials	3.8mm	10mm	30mm	Organ TVX64NY	1.0mm	39.2~78.4N(4~8kgf)
-2	light-medium materials	3.8mm	10mm	30mm	Organ TVX64NY	1.0mm	39.2~78.4N(4~8kgf)
-3	medium materials	3.8mm	10mm	30mm	Organ TVX64NY	1.0mm	39.2~78.4N(4~8kgf)



DA-928A



Three Needle feed off the arm double chain stitcher

Minimum lubrication system can be realizing clean sewing. Narrow cylinder bed feed off-the-arm double chain stitchers. Ideal for a wide range of materials from shirts to jeans. Clean sewing with minimum lubrication system, a new knife with highly safe shape, beautiful sewing finishes with new presser mechanism.

A new knife with highly safe shape

Sewing work can be done safely with a new knife with highly safe shape.

Rubber puller

For better efficiency rubber puller are available.

Specifications

Lubrication type	Minimum lubrication
Max. sewing speed	4,000 sti/min ^{*1}
Weight	49kg
Size	465mm x 500mm x 340mm
Outer perimeter of cylinder	171mm

^{*1} If thread breakage occurred during sewing of DA-928A, please lower the speed.

Model overview

	Applications	Max. stitch length	Height of presser foot	Needle bar stroke	Needle	Height of feed dog	Presser foot presser
-5	heavy materials	4.7mm	11mm	35mm	TVX5	1.3mm	58.8~98N(6~10kgf)
-7	extra heavy materials	4.7mm	11mm	35mm	TVX5	1.3mm	58.8~98N(6~10kgf)





brother

Internationale Industriemaschinen GmbH

Düsseldorfer Strasse 7-9
46446 Emmerich am Rhein, Germany
Tel.: +49 (0) 2822 609 0
E-mail: info@brother-ism.com
Web: industrialsewingmachine.global.brother

92 **Contact** | Brother Catalogue



Follow us on social media:



Brotherindustrial EMEA



Brother Industrial EMEA



Brother Industrial Sewing EMEA



